

- (3) Insert guide bar **K** of flange plate **J** into guide hole **M** of front plate **L** and press it in up to a point just before injection pump gear **G** comes in mesh with the idler gear.

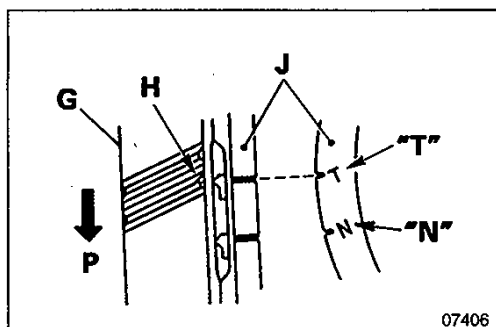

- (4) Check to see that alignment mark "**N**" <non-turbo> or "**T**" <turbo> of flange plate **J** is in alignment with notch **H** of injection pump gear **G**. Then press the injection pump assembly in. In this case, notch **H** of the gear comes in mesh as it turns in direction **P**.

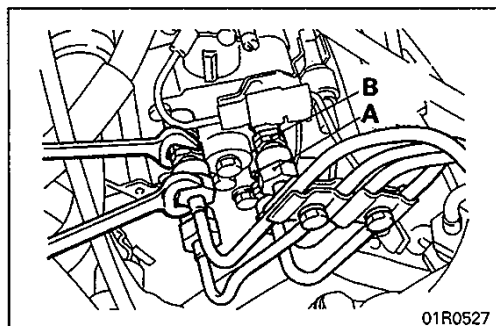

**❏C❏ FUEL INJECTION PIPE INSTALLATION**

- (1) Tighten the union nut **A** of the fuel injection pipe while locking the delivery valve holder **B** to prevent it from rotating together.

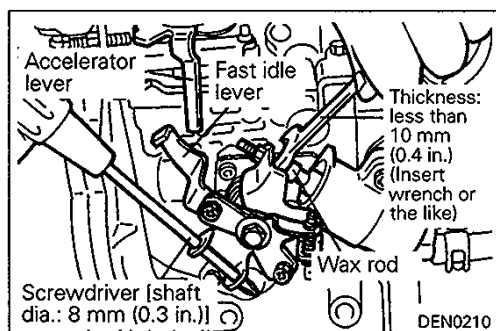

**FUEL INJECTION TIMING CHECK AND ADJUSTMENT**

**CHECKING**

- (1) Release the fast idle mechanism.  
 (a) Insert a screwdriver [shaft dia.: 8 mm (0.3 in.) ] into the holes at the bottom of the fast idle lever and turn the lever in the direction of the arrow as shown.

**Caution**

- **In order to prevent weakening of the spring, do not turn the lever any more than necessary.**

- (b) Insert a wrench or similar tool [thickness approx. 10 mm (0.4 in.) ] between the wax rod and the adjusting screw.

**Caution**

- **Do not turn the adjusting screw.**

- (c) Remove the screwdriver.

- (2) Loosen (but do not remove) two nuts and two bolts holding the injection pump.  
 (3) Loosen (but do not remove) the 4 nuts on the injection pump side which hold the injection pipes.

**Caution**

- **When loosening the nuts, hold the delivery valve holder with a wrench to prevent it from turning along with the nut.**

# 13A-5-4

## DIESEL – Fuel Injection Pump Assembly (4M40 ENGINE)

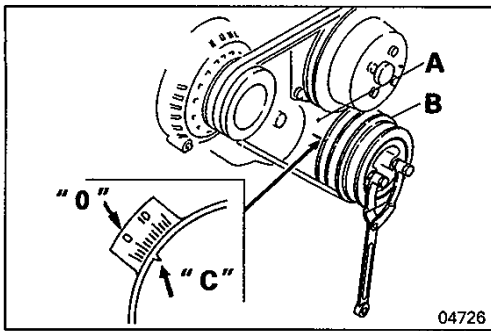

- (4) Remove all the glow plugs.
- (5) Crank up the engine to place No.1 piston at the TDC on the compression stroke. Align the notch **C** in the crankshaft pulley **B** with the timing mark "0" on the timing gear case **A**.

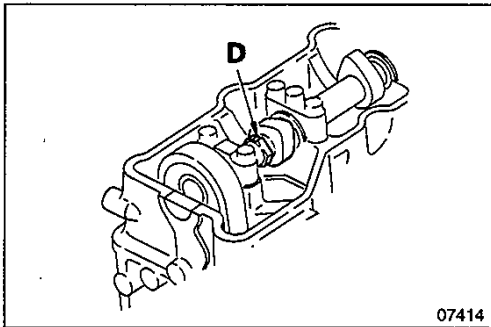

### NOTE

- (1) If dent **D** on the hexagonal portion of the camshaft is at the top position, then it means that the No. 1 piston is at the top dead center on the compression stroke. If the dent is not at the position, turn the crankshaft clockwise through another rotation.
- (2) Counter-clockwise rotation of the crankshaft could cause damage to the timing chain tensioner. If the crankshaft was turned counter-clockwise, remove the tensioner and remount it according to the installation procedure.

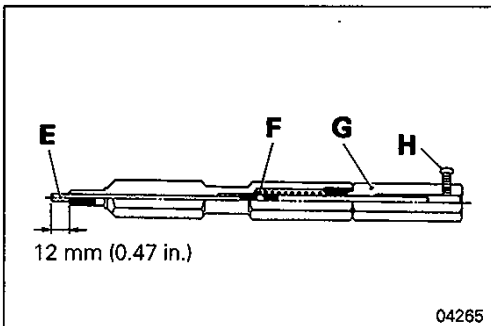

- (6) Check to ensure that push rod **E** of the special tool is projecting 12 mm (0.47 in.) from the end of the body.

### NOTE

Adjust the projecting dimension of the push rod by nut **F** in the body of the special tool.

- (7) Insert a dial indicator (small-size one) into holder **G**.
- (8) When the dial indicator has made contact with the push rod and the pointer has begun to move, secure the dial indicator with the screw.

### NOTE

Make use that the amount the pointer operates is 0.5 mm (0.02 in.) or less.

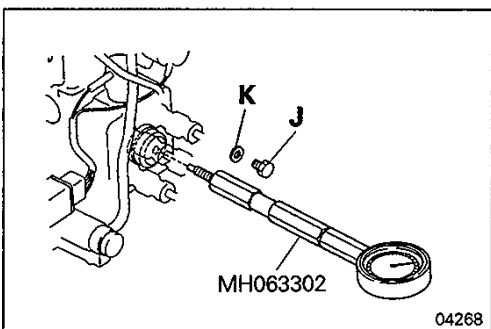

- (9) Remove the head plug **J** and gasket **K** from the fuel injection pump.
- (10) Thread the special tool in until the pointer of the dial indicator begins to move.

### NOTE

When the dial indicator is hard to see, the amount the special tool is threaded in should be adjusted within the range of less than a turn from the point where the pointer begins to move.

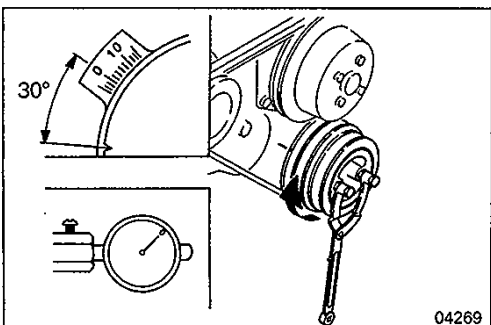

- (11) Turn the crankshaft clockwise again till No. 1 piston is set 30° before TDC on the compression stroke.
- (12) Zero the dial gauge.
- (13) Turn the crankshaft a little (2 to 3°) clockwise and counter-clockwise and check that the dial gauge still reads "0".

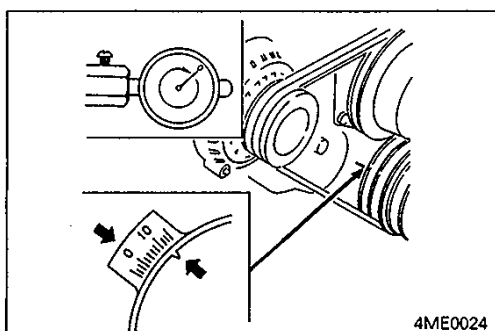

4ME0024

- (14) Set No.1 cylinder piston to the fuel injection timing by turning the crankshaft clockwise. At this point, read the dial gauge to measure the valve lift.

**NOTE**

For the fuel injection timing refer to "SERVICE SPECIFICATIONS".

**Plunger lift:  $1 \pm 0.03$  mm ( $0.039 \pm 0.0012$  in.)**

**NOTE**

The timing mark scale is graduated  $2^\circ$  apart.

- (15) If the reading deviates from the specified standard value, make necessary adjustment as follows:

**ADJUSTMENT**

- (1) Loosen the injection pipe union nut **K** as well as the bolt **L** and nut **M** holding the fuel injection pump in this order.

**K:** Fuel injection pipe union nut (4 places)

**L:** Bolt (1 place)

**M:** Nut (2 places)

**Caution**

- When loosening the union nuts **K**, lock the delivery valve holder with a wrench to prevent it from turning together.
- Do not remove the union nuts **K**, bolt **L** and nuts **M**. Just loosen.

- (2) Adjust the fuel injection timing by tilting the fuel injection pump assembly right or left till the dial gauge reads the specified value.

**P:** In case the reading exceeds the specified standard value.

**Q:** In case the reading is below the specified standard value.

- (3) After the adjustment, check again to see if the dial gauge indicates the specified plunger lift.

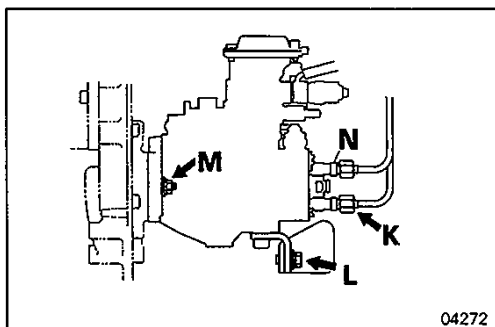

04272

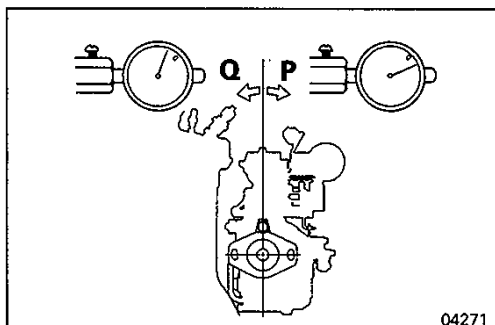

04271

- (4) Retighten the nuts and bolt in the order of **M**, **L** and **K**.

**M:** Nut (2 places)

**L:** Bolt (1 place)

**K:** Fuel injection pipe union nut (4 places)

**T = 23 Nm (2.3 kgm, 17 ft.lbs.)**

**Caution**

- When torquing the union nuts **K**, lock the delivery valve holder with a wrench to prevent it from turning together.

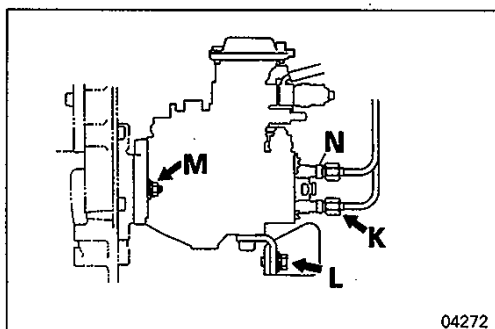

04272

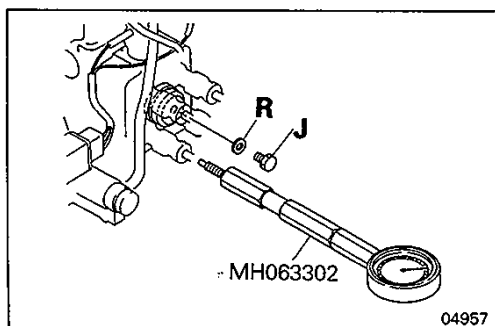

04957

- (5) Remove the special tool.

- (6) Replace the gasket **R** with a new one, and tighten the head plug **J** to the specified torque.

**T = 17 Nm (1.7 kgm, 12 ft.lbs.)**