

■ ACTIVE HEIGHT CONTROL SUSPENSION AND SKYHOOK TEMS (TOYOTA ELECTRONIC MODULATED SUSPENSION)

1. General

- The active height control suspension and skyhook TEMS is a suspension system in which comfort and convenience have been significantly improved through the integration of a vehicle height adjustment system and a damping force control system.
- The vehicle height adjustment system improves the occupants' in-and-out access by quickly lowering the vehicle height at the touch of a switch. Furthermore, by raising the vehicle height, the occurrence of road interference can be minimized on unpaved roads. Also, by maintaining a constant vehicle height regardless of the load conditions such as the number of occupants or the weight of the cargo, under the prescribed loading condition the suspension stroke can be utilized effectively to ensure constantly stable riding comfort.
- Based on the skyhook theory, the damping force control system controls the suspension to achieve an optimal damping force in accordance with the bumpiness of the road surface. Furthermore, through the use of the various types of sensors, this system detects the vehicle's operating condition to obtain an optimal damping force to provide excellent riding comfort, stability, and controllability.
- The M-OBD (Multiplex On-Board Diagnostic) system is supported.

2. System Function

Vehicle Height Control Function

1) Vehicle Height Selection Function

The following three types of vehicle heights can be selected by operating the switch: normal vehicle height (N), low vehicle height (Lo), and high vehicle height (Hi).

Selected Height Position		Lo	N	Hi
Vehicle Height	Front	Approximately –50 mm (–2.0 in.)	Standard Vehicle Height	Approximately +40 mm (+1.6 in.)
	Rear	Approximately –40 mm (–1.6 in.)	Standard Vehicle Height	Approximately +50 mm (+2.0 in.)
Vehicle Height Adjustment Speed	Up	Lo to N or N to Hi Approximately 10 to 15 seconds* (Main accumulator in the stored state)		
	Down	Hi to N or N to Lo Approximately 3 to 8 seconds*		

*: Vehicle height control speed differs depending on the loaded condition.

2) Automatic Leveling Function

This function maintains the vehicle height constant regardless of the load conditions such as the number of occupants or the weight of the cargo under the prescribed loading condition. It effects constant control so that the vehicle height is maintained at a prescribed value when the normal vehicle height is selected.

3) Vehicle Speed Sensing Function

This function automatically adjusts the vehicle height in accordance with the vehicle speed in order to ensure stability and riding comfort while driving.

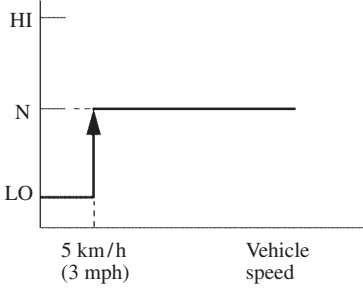
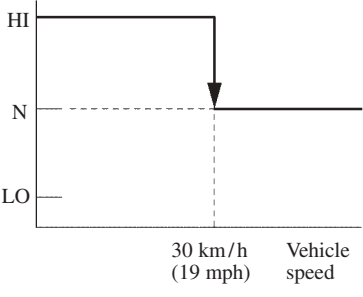
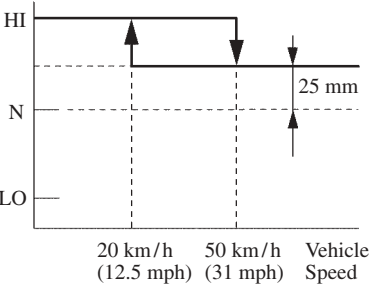
During Lo Position	During Hi Position	During Hi Position*
 <p style="text-align: right;">155CH19</p>	 <p style="text-align: right;">155CH20</p>	 <p style="text-align: right;">155CH21</p>
<p>When the vehicle speed becomes higher than approximately 5 km/h (3 mph), the vehicle height transfers to normal. The normal vehicle height is maintained even if the vehicle speed becomes lower than 5 km/h (3 mph).</p>	<p>When the vehicle speed becomes higher than approximately 30 km/h (19 mph), the vehicle height transfers to normal. The normal vehicle height is maintained even if the vehicle speed becomes lower than 30 km/h (19 mph).</p>	<p>When the vehicle speed becomes higher than approximately 50 km/h (31 mph), the vehicle height transfers to a height that is approximately 25 mm (1 in.) higher than the normal vehicle height. When the vehicle speed becomes lower than approximately 20 km/h (12.5 mph), it returns to the high vehicle height.</p>

*: Transfer shifted in the low.

4) Extra High Mode

While driving on an unpaved road with the transfer shifted in the low range and the vehicle height set to high, if one of the wheels freewheels, the vehicle height raises automatically by approximately 30 mm (1.2 in.) at the front and approximately 20 mm (0.8 in.) at the rear.

5) Vehicle Height Adjustment Prohibition Control

When the vehicle is raised on a jack or is being towed, the vehicle adjustment can be prohibited by operating the height control switch. However, the prohibition control cancels automatically when the vehicle speed becomes higher than approximately 80 km/h (50 mph) at the normal vehicle height, or higher than approximately 30 km/h (19 mph) at the high or low vehicle height.

NOTE: Occasionally, the set vehicle height may not be maintained when the vehicle is carrying a load that is heavier than a prescribed amount. At times, it might not be possible to raise the vehicle height even by operating the switch.

- Up to 4 occupants* plus about 300 kg (661 lb.) in the normal mode.
- Up to 4 occupants* plus about 170 kg (375 lb.) in the high mode.

*: About 68 kg (150 lb.) for a person.

Damping Force Control Function

1) Float and Pitch Control (Skyhook Control)

Based on the skyhook theory to take semi-active control of the damping force, this function effects independent front/rear control of the damping force in order to achieve an optimal damping force in accordance with the bumpiness of the road surface.

The suspension control ECU calculates the relative speed between the body and the wheels based on the signals received from the height control sensor and controls the actuators to maintain a flat and stable vehicle posture in various road conditions.

a. Skyhook Theory

This theory proposes an imaginary shock absorber suspended in the air. This imaginary shock absorber is inactive against any force that is applied from the ground, but effectively activates a damping force against body vibrations.

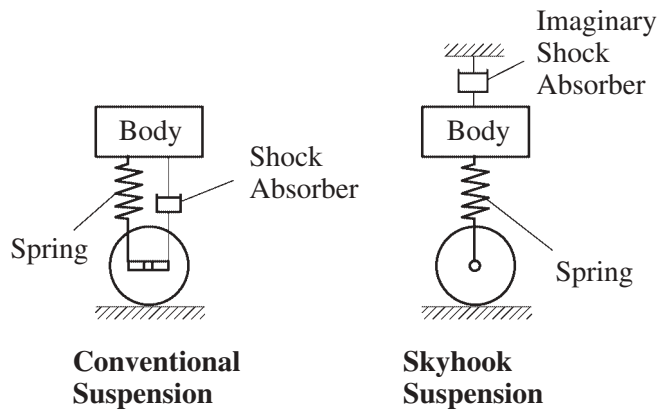

155CH22

b. Semi-Active Control

The conditions in which the vehicle overcomes mild bumps are demonstrated through the use of a model in the following four conditions:

- ① The shock absorber contracts and the body moves upward.
- ② The body keeps moving upward causing the shock absorber to elongate gradually.
- ③ The shock absorber keeps elongating and the body starts moving downward.
- ④ The body keeps moving downward causing the shock absorber to contract gradually.

Stage ①	Stage ②	Stage ③	Stage ④
<p>Body Movement Damping Force</p> <p>Easy to Contract</p> <p>155CH23</p>	<p>Body Movement Damping Force</p> <p>Hard to Expand</p> <p>155CH24</p>	<p>Body Movement Damping Force</p> <p>Easy to Expand</p> <p>155CH25</p>	<p>Body Movement Damping Force</p> <p>Hard to Contract</p> <p>155CH26</p>
Assisting the Vibrations	Suppressing the Vibrations	Assisting the Vibrations	Suppressing the Vibrations

Thus, during stages ① and ③ the shock absorbers assist the vibration to create a softer damping force, and during stages ② and ④ the shock absorber suppress the vibration to create a hard damping force, the shock absorbers are minutely controlled to suppress the vibration to restrain the movement of the body and of the shock absorbers.

The above processes are performed independently between the front and rear wheels in order to stabilize the vehicle to a flat posture.

2) Thumping Sensitive Control

When the road surface condition does not require a damping force, this function controls the actuator so that their damping force will not increase.

As a result, both flatness and a soft ride have been achieved.

3) Unsprung Vibration Control

If unsprung resonance is detected, this function controls so that the damping force will not decrease below a certain level, in order to reduce the unsprung resonance.

As a result, excellent road-holding performance has been ensured without affecting riding comfort.

4) Speed Sensitive Control

To optimally balance the vehicle's riding comfort and road-holding performance, the damping force is increased along with the increase in vehicle speed, in order to ensure stability during high-speed driving.

5) Anti-Roll Control

During cornering, this function makes the damping force firmer, thus restraining the body roll speed in order to provide excellent stability and controllability.

6) Anti-Dive Control

During braking, this function makes the damping force firmer to restrain the body dive, thus ensuring excellent stability and controllability.

7) Anti-Squat Control

During acceleration, this function makes the damping force firmer to minimize the changes in the vehicle body posture to provide excellent stability and controllability.

8) Damping Force Control

The actuator uses a 16-step step motor to generate a continually variable damping force. This provides a wide selection of damping force and enables a smooth transition of the damping force.

As a result, a minutely controlled damping force that accommodates various types of driving conditions has been made possible.

Right-Left Wheel Communicating Function

Normally, an oil passage remains open between the shock absorbers for the right and left wheels. This enables the suspension to contract and elongate smoothly when the right and left wheels move gradually at opposite phases and provides excellent road-holding performance while driving on a winding road.

When the driver operates the steering wheel, the oil passage between the right and left shock absorbers closes according to that condition. This restrains the increase of the vehicle body roll during cornering, thus ensuring the vehicle's stability and controllability.

3. Layout of Components

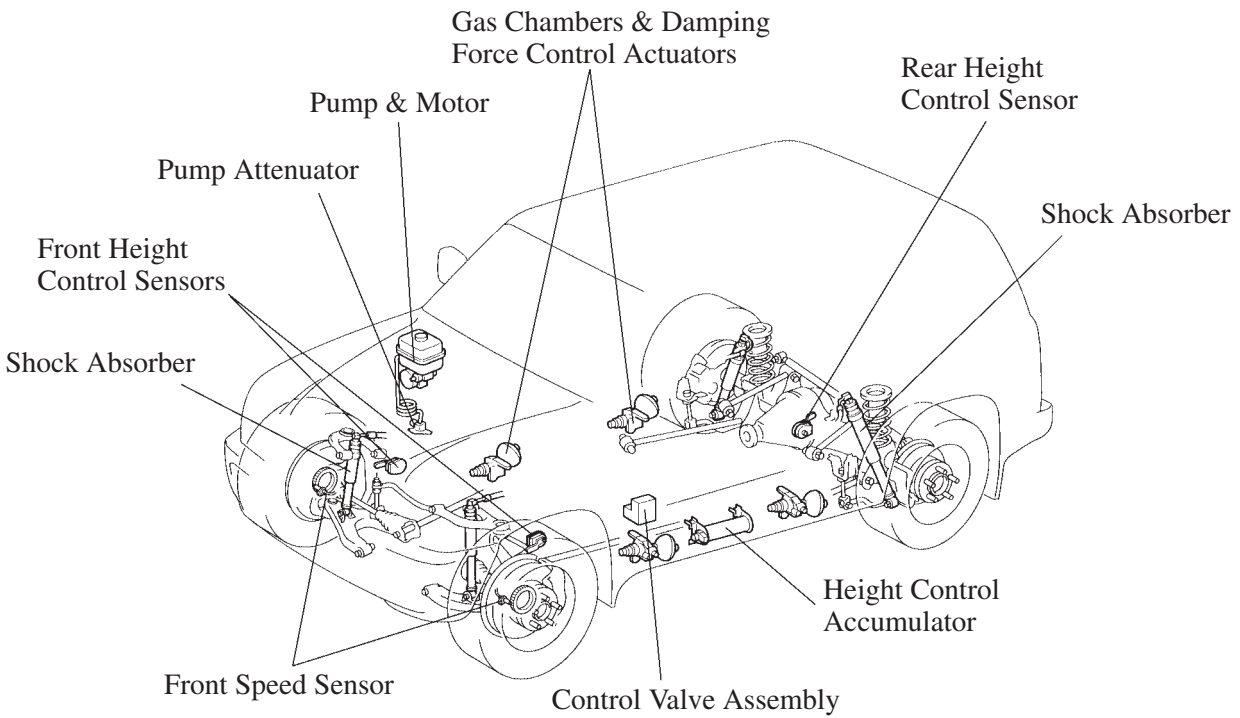

155CH94

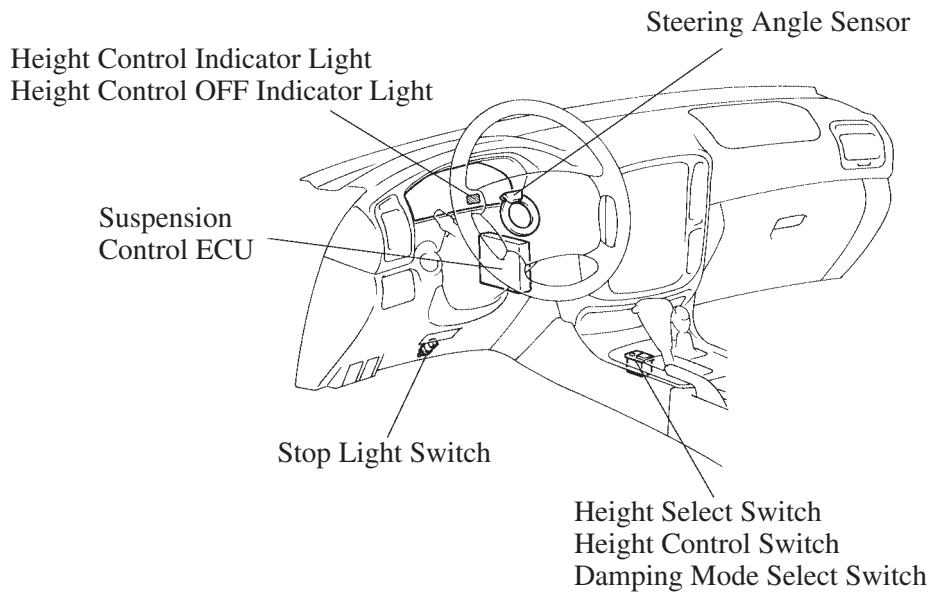

155CH95

LHD Model

4. Function of Components

Components		Function
Height Control Indicator Light		Indicates the present vehicle height condition.
Height Control OFF Indicator Light		<ul style="list-style-type: none"> ● Lights to inform the driver when the active height control system is turned OFF by the height control switch. ● Blinks to alert the driver when the ECU detects the malfunction in the active height control suspension and skyhook TEMS. ● Indicates the diagnostic code.
Height Select Switch		Selects the target vehicle height.
Height Control Switch		Prohibits the adjustment of the vehicle height.
Damping Mode Select Switch		Selects a damping force control mode.
Front Speed Sensors		Detect the wheel speed.
Height Control Sensors		Detect the vehicle height.
Steering Angle Sensor		Detects the steering direction and angle of the steering wheel.
Pump and Motor		Generates the high hydraulic pressure that is necessary for raising the vehicle height.
	Reservoir Tank	Maintains the amount of fluid that is returned during the low vehicle height and the amount of fluid that is discharged during the high vehicle height.
	Return Valve	Opens and closes the oil passage between the control valve assembly and the reservoir tank.
	Pressure Sensor	Detects the pump's discharge pressure.
	Temperature Sensor	Detects the fluid temperature.
Pump Attenuator		Dampens the hydraulic pulsation of the fluid that is discharged by the pump.
Height Control Accumulator		Stores the hydraulic pressure to accelerate the speed in which the vehicle height is raised.
Control Valve Assembly	Leveling Valves	Open and close the oil passage between the pump and the gas chambers of the wheels.
	Gate Valves	Open and close the oil passage between the right and left shock absorbers.
Gas Chambers		Perform the same functions as those of the gas chamber of the conventional shock absorber.
Damping Force Control Actuators		Switch the damping force.
Shock Absorbers		Generate a damping force similar to the conventional shock absorber.
High Pressure Hose		Serves as the oil passage that links the gas chambers and the shock absorbers.
Suspension Control ECU		Controls the entire system by performing the calculations for height control and damping force control based on the signals received from the sensors and switches.
Center Diff. Lock Position Switch		Detects that the center differential is locked.
L4 Position Switch		Detects the transfer shifted in the low.
Stop Light Switch		Detects the brake signal.
Courtesy Switches		Detects the open and closed condition of the doors.
Generator L Terminal		Detects that the engine is operating.
AHC Main Relay		Supplies power to the suspension system.
AHC Motor Relay		Supplies power to the pump motor.

5. Construction and Operation of Main Components

Indicator Lights

1) Height Control Indicator Light

The height control indicator light has been provided below the tachometer in the combination meter. It informs the driver by illuminating the indicator light for the present vehicle height position.

When the height select switch is pressed to effect height control, the indicator for the present height position turns OFF and the indicator light for the target height position blinks. After height control is completed, the indicator light for the height position that has been attained illuminates.

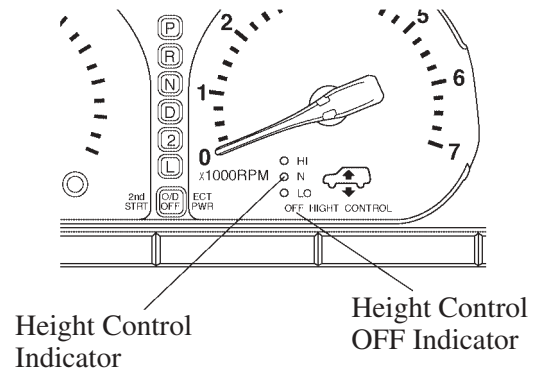

155CH70

2) Height Control OFF Indicator Light

The height control OFF indicator light is located under the height control indicator light.

This indicator light lights up to inform the driver when the active height control system is turned off by the height control switch.

This indicator light blinks to alert the driver when the ECU detects the malfunction in the active height control suspension and skyhook TEMS.

By effecting the DTC (Diagnostic Trouble Code) check mode, the DTCs can be obtained from this indicator light. For details, see the Land Cruiser Chassis and Body Repair Manual (Pub. No. RM616E).

Control Switches

The height select switch, the height control switch and the damping mode select switch are located in front of the shift lever.

Damping Mode Select Switch

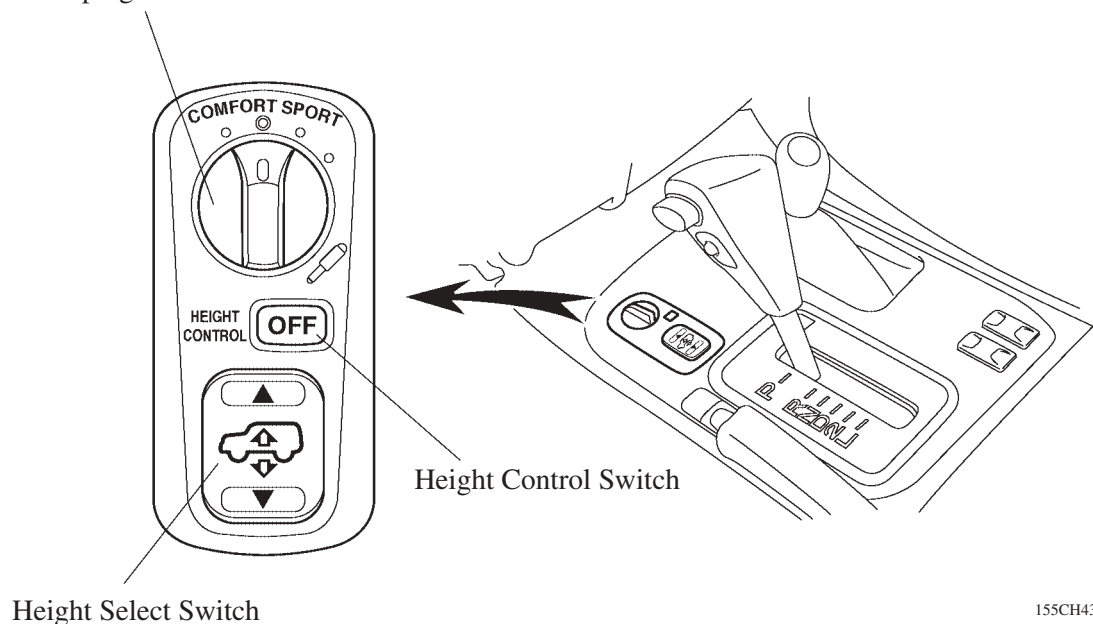

155CH43

1) Height Select Switch

A seesaw type momentary switch has been adopted for the height select switch that is used for selecting a desired height. Pressing the ▲ (up) side of the switch once raises the vehicle height, and pressing the ▼ (down) side once lowers the vehicle height.

2) Height Control Switch

Pressing this switch prohibits the height control function. Pressing it again cancels the prohibition. The prohibition cancels automatically when the vehicle speed becomes higher than 80 km/h (50 mph) at the normal vehicle height, or higher than 30 km/h (19 mph) at any other vehicle height. The state of height control prohibition is stored in memory even after the ignition switch has been turned OFF.

3) Damping Mode Select Switch

As shown on the right, this control switch enables the driver to select a desired damping force from the 4 modes.

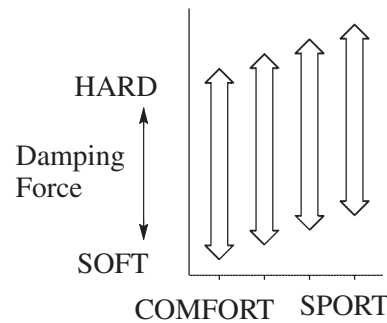

155CH27

Select Switch Position

Front Speed Sensors

The sensors detect the individual speeds of the front wheels. The wheel speed signals are then input into the suspension control ECU via the ABS & hydraulic brake booster ECU.

Height Control Sensors

A total of 3 sliding resistance type height control sensors are provided: 1 in each of the right and left front wheel housings and 1 in the center of the cross member located above the rear axle.

The sensor consists of a brush that is integrated with a shaft, which slides on the resistor that is formed on a substrate. Because the resistance value between the brush and the resistor terminal varies in proportion to the shaft's rotational angle, a prescribed amount of voltage is applied to the resistor so that a change in the rotational angle can be detected in the form of a voltage change.

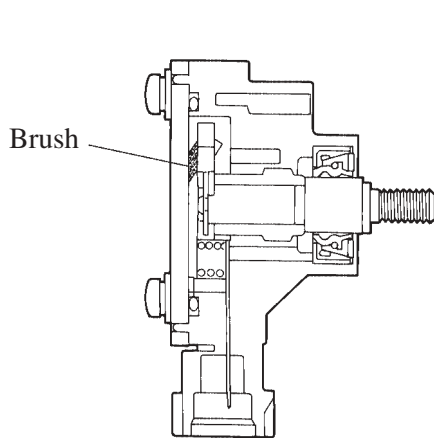

155CH71

Cross Section

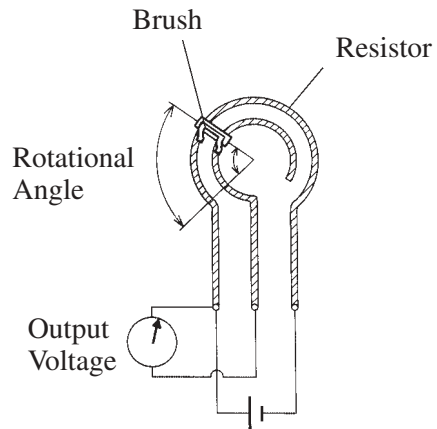

155CH41

Diagram of the Principle

Steering Angle Sensor

The steering angle sensor is fitted to the turn signal switch assembly and detects the steering direction and angle.

The sensor contains 2 photo interrupters with phases, and a slotted disc interrupts the light to turn the photo transistor ON and OFF to detect the steering direction and angle.

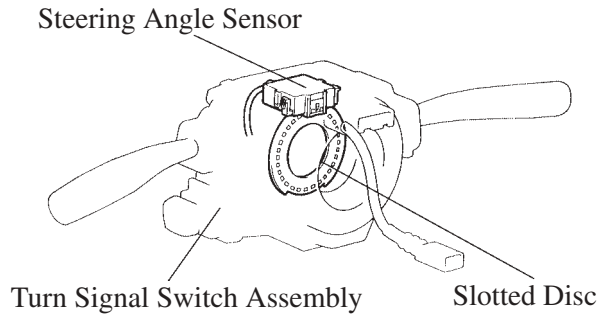

Pump and Motor

155CH42

A system in which the pump, pump motor, reservoir tank, return valve, pressure sensor, and temperature sensor are integrated has been adopted.

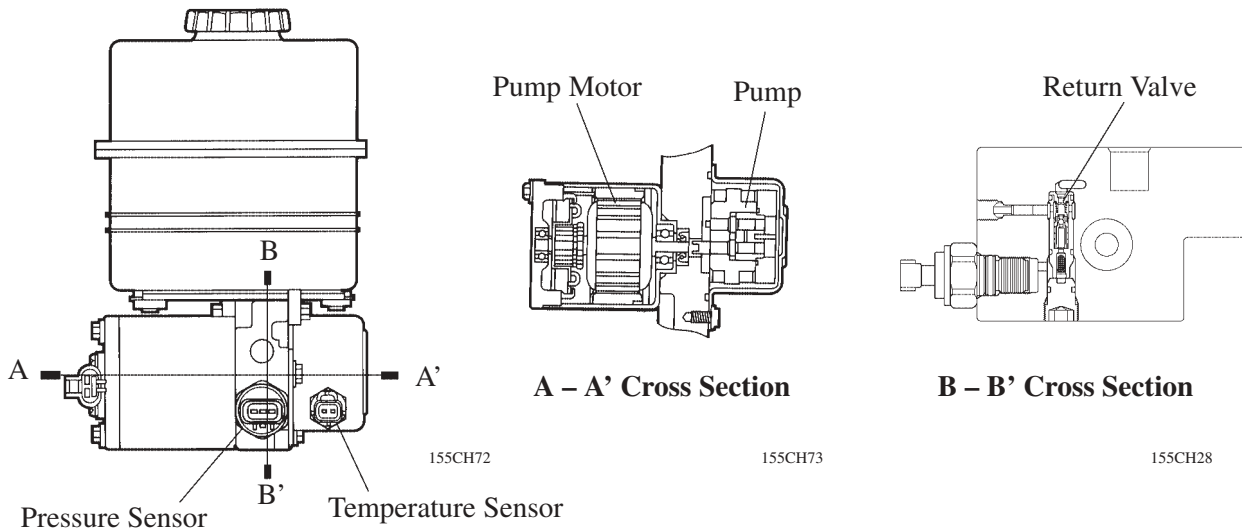

1) Pump

An external gear pump that contains less parts and excels in durability has been adopted. Also, the pump is a pressure-loading type in which the discharge pressure of the pump itself is utilized and routed via the gear case to push on the side of the pump gear in order to reduce the internal leakage, thus making high-pressure discharge possible.

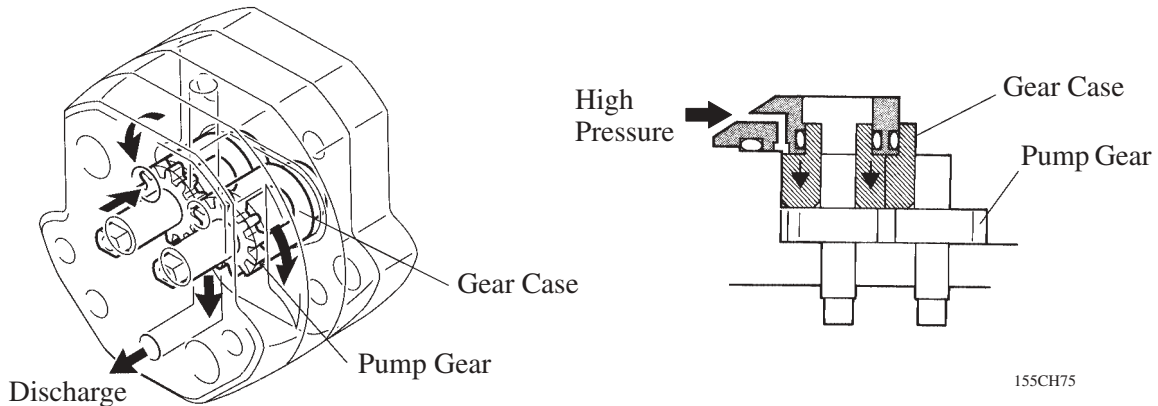

155CH74

155CH75

2) Motor

A DC motor with 4-pole brushes has been adopted to realize excellent durability and high torque.

3) Return Valve

The return valve opens and closes the oil passage between the control valve assembly and the reservoir tank. The return valve has been simplified by adopting a construction in which the valve is closed by the flow of the discharged fluid.

Normally, a spring force is applied to the return valve to maintain the oil passage between the control valve assembly and the reservoir tank open.

When the pump operates in order to raise the vehicle height, the pressure of the fluid that is discharged by the pump causes the return valve to move to the left of the diagram as illustrated.

Accordingly, the oil passage between the control valve assembly and the reservoir tank closes, and the fluid that is discharged from the pump flows towards the control valve assembly.

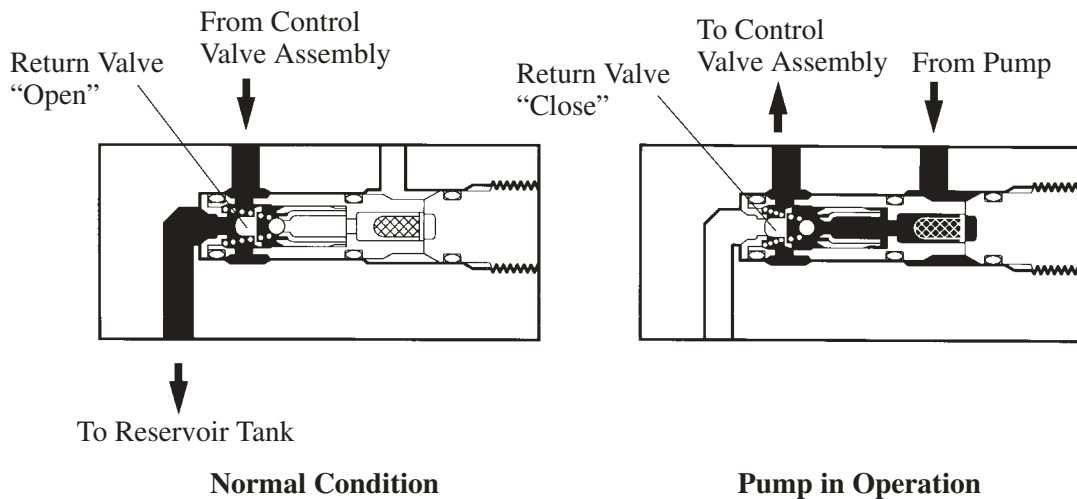

155CH76

CH

Pump Attenuator

The pump attenuator dampens the hydraulic pulsation of the fluid that is discharged by the pump.

A bellows type accumulator that is made of stainless steel, which offers excellent gas penetration resistance and good pulsation absorption performance, has been adopted.

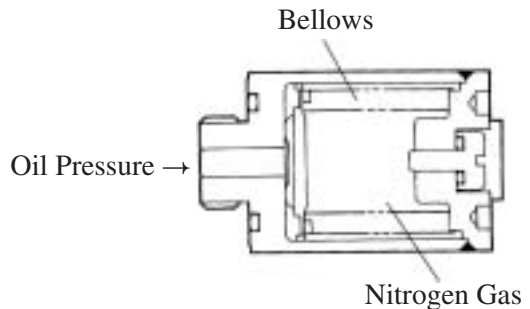

155CH77

► Specifications ◀

Sealed Gas	Nitrogen Gas
Gas Chamber Volume cc (cu in.)	2 (0.12)
Sealed Gas Pressure MPa (kgf/cm ² , psi)	1.96 (20, 284)

Height Control Accumulator

A free piston type accumulator, which provides a large gas chamber capacity, has been adopted for the height control accumulator.

The height control accumulator consists of a cylinder, free piston, and solenoid valve. When raising the vehicle height, the accumulator discharges the stored fluid to accelerate the raising speed.

Normally, the solenoid valve remains closed. When the vehicle height is being raised or the fluid is being stored in the main accumulator, the solenoid valve opens in accordance with the signal received from the suspension control ECU.

► Specifications ◀

Sealed Gas	Nitrogen Gas
Gas Chamber Volume cc (cu in.)	945 (57.7)
Sealed Gas Pressure MPa (kgf/cm ² , psi)	5.9 (60, 853)

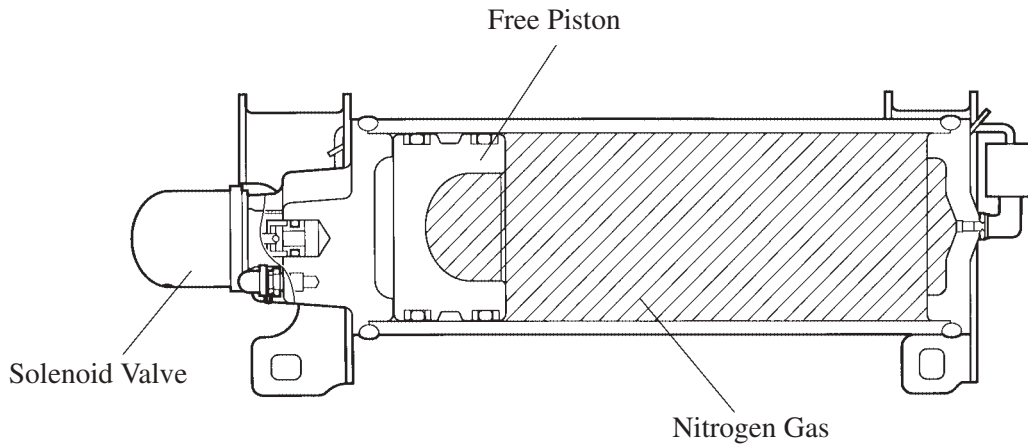

155CH78

Control Valve Assembly

The control valve assembly consists of the leveling valves for adjusting the vehicle height and the gate valves for controlling the right-left wheel communicating function. There are 4 valves each for the front and rear.

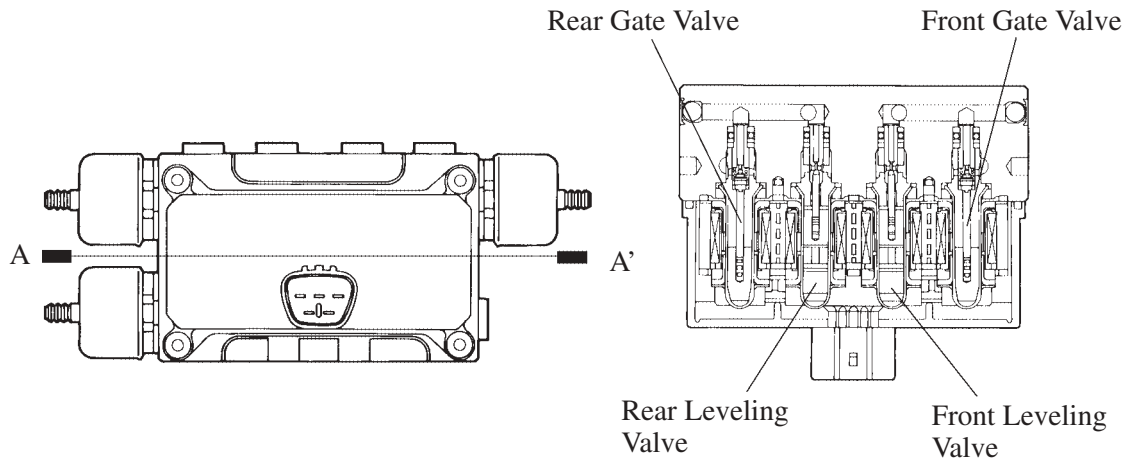

A – A' Cross Section

155CH79

1) Leveling Valve

This valve opens and closes the oil passage between the pump and the gas chamber located at each wheel. Normally, the oil passage remains closed, and during vehicle height control, the oil passage opens in accordance with the signal received from the suspension control ECU.

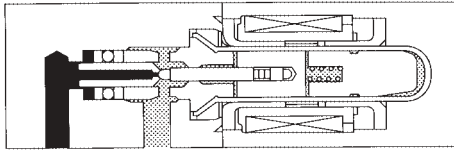

Wheel Side Pump Side

Close

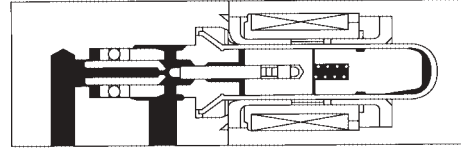

Wheel Side Pump Side

Open

155CH80

2) Gate Valve

This valve opens and closes the oil passage between the right and left shock absorbers. Normally, the oil passage remains open, connecting the right and left shock absorbers. When the suspension control ECU determines that the oil passage between the right and left shock absorbers must be closed, the gate valve activates to close the oil passage.

CH

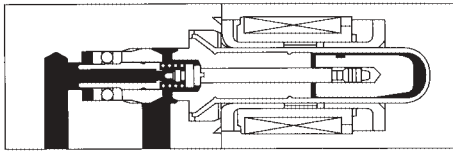

Left Side Right Side

Open

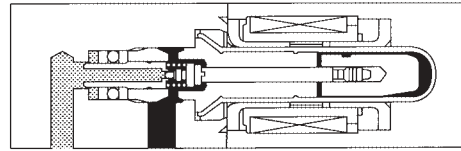

Left Side Right Side

Close

155CH81

Gas Chamber and Damping Force Control Actuator

A gas chamber (a substitute for the gas chamber in the conventional shock absorber) and an actuator to switch the damping force have been integrated.

The housing is provided with heat dissipating fins to improve the dissipation of the heat that is generated by the actuator.

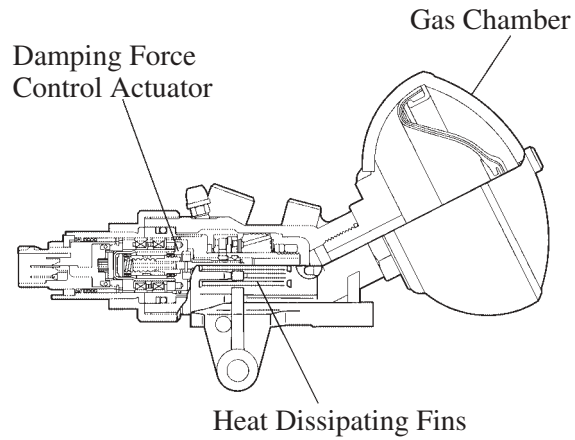

155CH93

1) Gas Chamber

The gas chamber uses the bladder type hydropneumatic accumulator.

A resin membrane is sandwiched between rubber layers to realize excellent gas penetration resistance.

The internal pressure of the gas chamber is varied by allowing the fluid to flow in and out of this gas chamber in order to raise or lower the vehicle height.

► Specifications ◀

	Front	Rear
Sealed Gas	Nitrogen Gas	←
Gas Chamber Volume cc (cu in.)	400 (24.4)	500 (30.5)
Sealed Gas Pressure MPa (kgf/cm ² , psi)	2.26 (23, 327)	2.65 (27, 384)

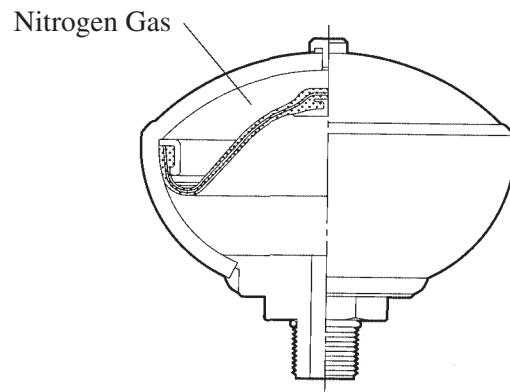

155CH82

2) Damping Force Control Actuator

This actuator consists of the 16 steps step motor, a screw mechanism (which converts the rotational movement to a linear movement), a spool valve, a soft damping force valve and hard damping force valve.

Signals from the suspension control ECU activate the actuator causing the spool valve to switch the oil passage. Thus, the volume of oil that passes through each valve is varied in order to control the damping force in 16 steps.

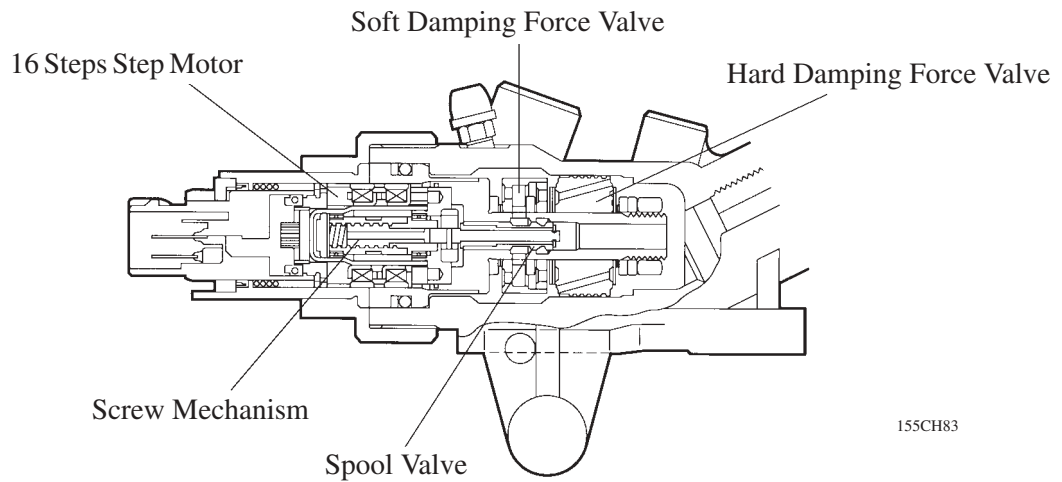

155CH83

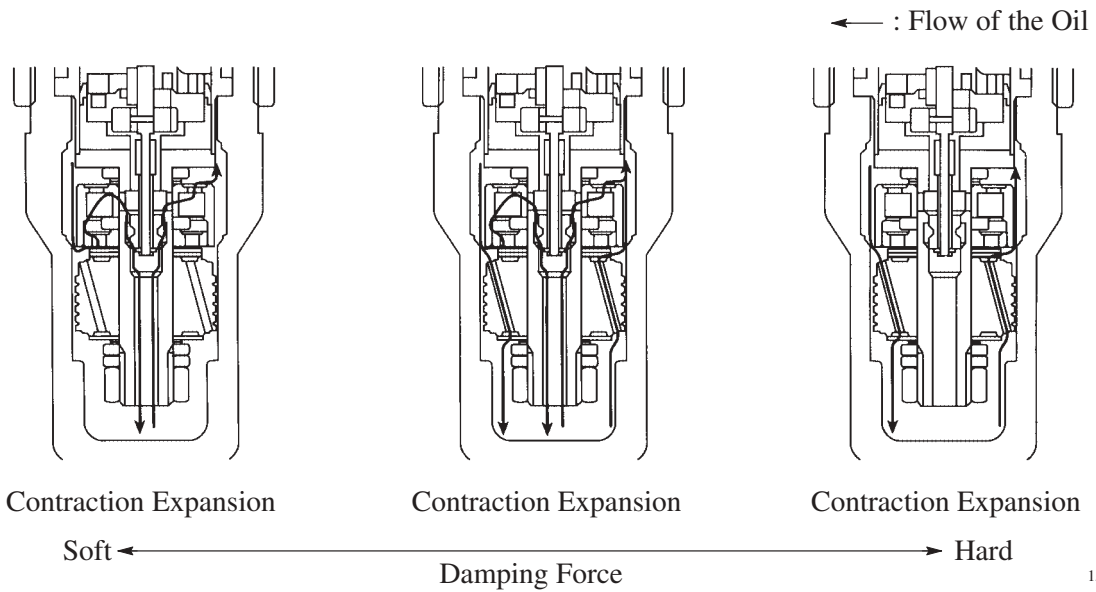

155CH84

CH

Shock Absorber

The shock absorber has adopted a dual construction using a high-pressure main seal made of fluoroethylene resin and a high-pressure oil seal made of nitrile rubber and provided with a backup ring in order to ensure sealing performance and to reduce friction.

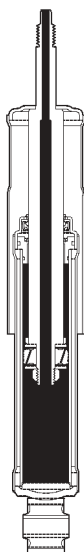

155CH29

Front Shock Absorber



155CH30

Rear Shock Absorber

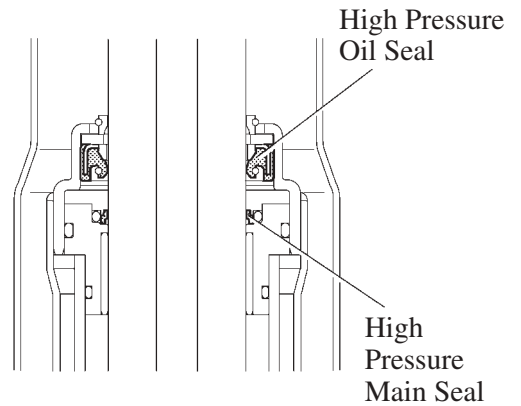

155CH14

Seals

Fluid

This system uses a fluid called the “Active Suspension Fluid AHC”.

Suspension Control ECU

1) General

The suspension control ECU is located in the driver’s side instrument panel.

Based on the signals received from the sensors and switches, the suspension control ECU detects the vehicle height and vehicle conditions and outputs the control signals to the actuators and the pump.

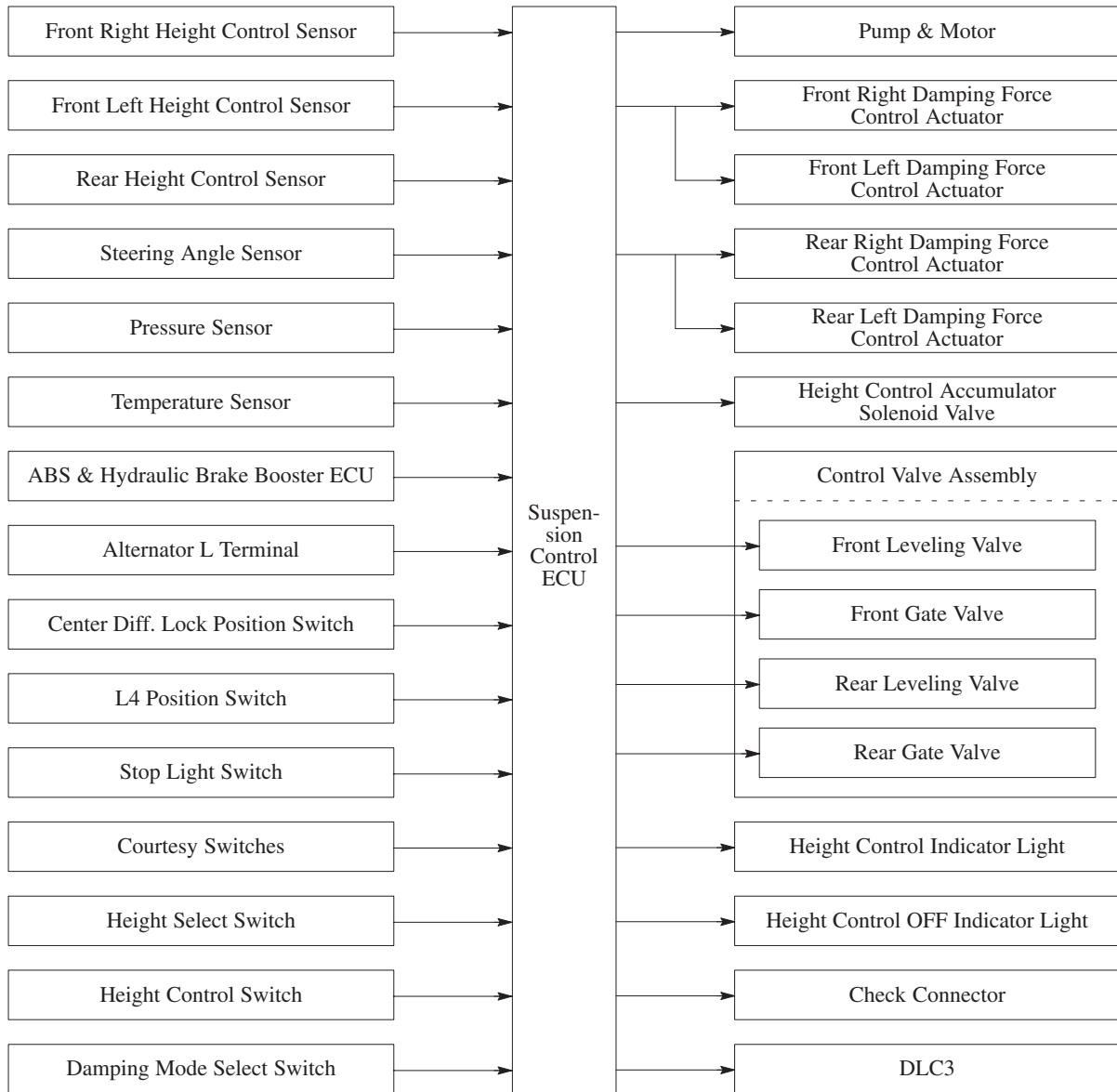

2) Self-Diagnosis

If the suspension control ECU detects a malfunction in this system, it blinks the height control OFF indicator light to alert the driver of the malfunction. The ECU will also store the codes of the malfunctions. The diagnostic trouble codes (DTCs) can be accessed through the blinking of the height control OFF indicator light or the use of a hand-held tester. For details, see the Land Cruiser Chassis and Body Repair Manual (Pub. No. RM616E).

3) Test Mode

The operation of the sensors and the switches can be inspected in the test mode. For details, see the Land Cruiser Chassis and Body Repair Manual (Pub. No. RM616E).

4) Active Test

A Lexus hand-held tester can be used to activate the actuators for inspecting their operation. For details, see the Land Cruiser Chassis and Body Repair Manual (Pub. No. RM616E).

5) Fail-Safe

If a malfunction occurs in any of the sensors or actuator, the ECU prohibits the vehicle height control and the damping force control.

6. System Operation

Normal Driving (Straightline Driving)

The high pressure in the gas chamber and the shock absorber is shut off with the leveling valve. The gate valve remains open, and the right and left shock absorbers remain connected. The damping force is controlled in accordance with road surface conditions.

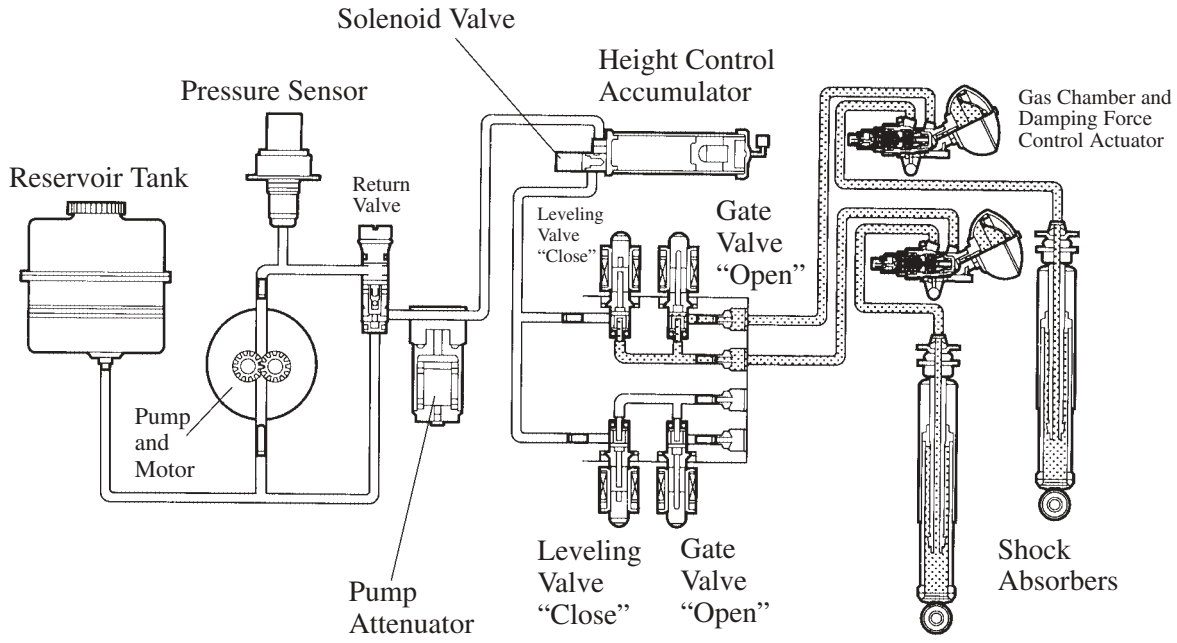

155CH85

Cornering

The high pressure in the gas chamber and the shock absorber is shut off with the leveling valve. The gate valve is closed, and the right and left shock absorbers are shut off from each other. The damping force is controlled in accordance with road surface conditions and the operating condition of the steering wheel.

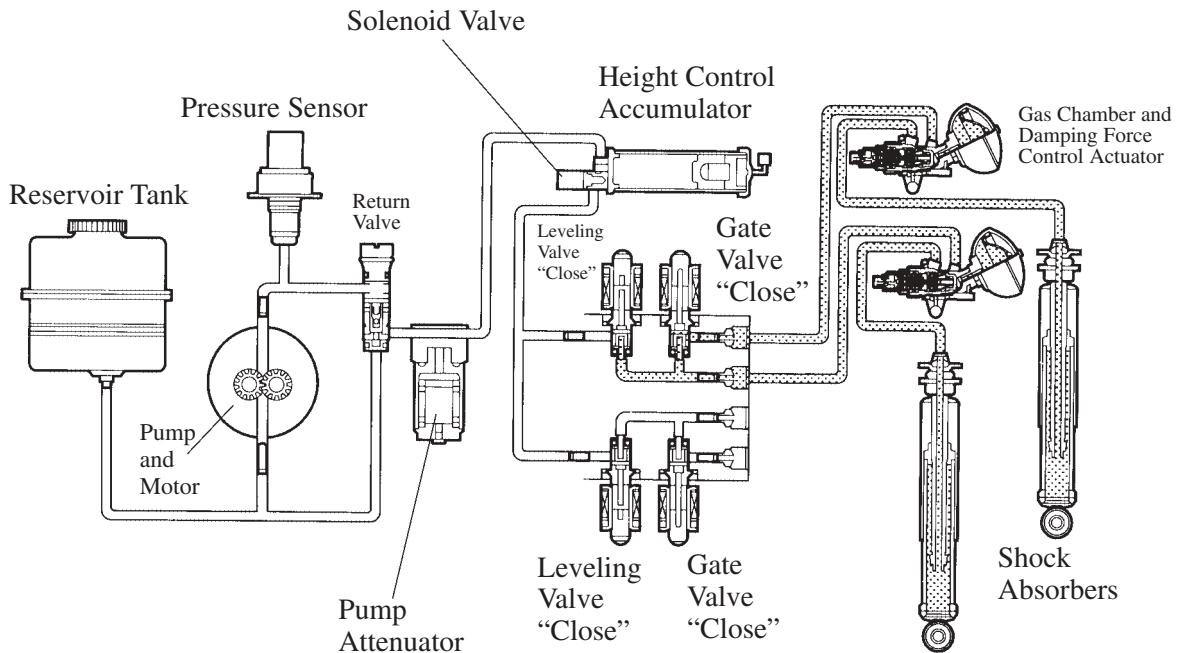

155CH85

Raising the Vehicle Height

Operating the height select switch to raise the vehicle height activates the pump motor, which rotates the pump. The fluid that is discharged by the pump is sent to the gas chambers and shock absorbers in order to raise the vehicle height.

1) Vehicle Stopped

The solenoid valve of the height control accumulator is opened in order to use the fluid that is stored in the height control accumulator, which accelerates the raising speed of the vehicle height.

To use the fluid that is stored in the accumulator, the front and rear leveling valves are opened simultaneously to raise all 4 wheels at the same time.

When the stored fluid has been depleted, the front and rear leveling valves are opened alternately to raise the suspension of the front wheels and the rear wheels alternately.

2) Vehicle in Motion

When the vehicle speed is less than approximately 25 km/h (16 mph), the fluid that is stored in the height control accumulator is used in the same way as when the vehicle is stopped.

When the vehicle speed is higher than approximately 25 km/h (16 mph), the vehicle height is raised using only the fluid that is discharged by the pump, without using the height control accumulator. At this time, the front and rear leveling valves are opened alternately to raise the suspension of the front wheels and the rear wheels alternately.

When the vehicle height is at low, it is automatically raised to normal when the vehicle speed becomes higher than approximately 5 km/h (3 mph). At this time, the fluid that is stored in the height control accumulator is also used.

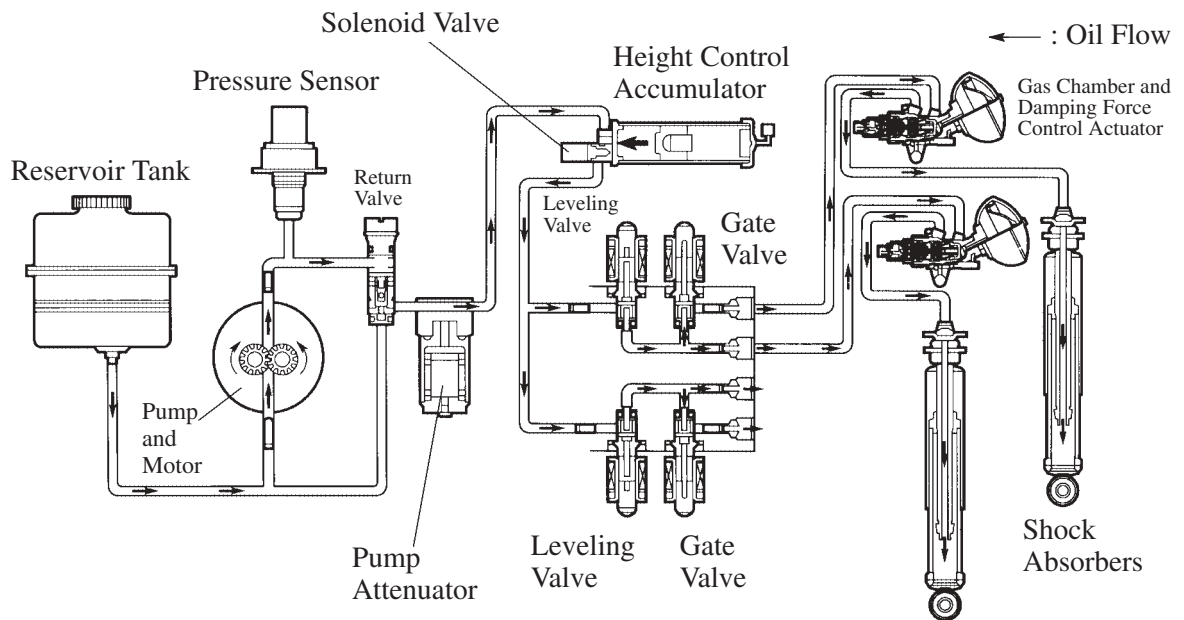

155CH86

Condition			Vehicle Stopped		Vehicle in Motion	
			Use Height Control Accumulator	Not Use Height Control Accumulator	25 km/h (16 mph) or less and at the time of using the height control accumulator	Except the left mentioned condition
Control Valve Assembly	Front	Leveling Valve	Open	Open and Close	Open	Open and Close
		Gate Valve	Open	Open	Open	Open
	Rear	Leveling Valve	Open	Open and Close	Open	Open and Close
		Gate Valve	Open	Open	Open	Open
Height Control Accumulator Solenoid Valve			Open	Close	Open	Close
Pump and Motor			Operation	Operation	Operation	Operation

Fluid Stored in Height Control Accumulator

Normally, the height control accumulator stores only the amount of fluid that is equivalent to that used in raising the vehicle height once. Therefore, after the vehicle has been raised from low to normal, or from normal to high, it is necessary to replenish the fluid in the height control accumulator.

At this time, the pump motor is operated to rotate the pump, the leveling valves are closed, the solenoid valve of the height control accumulator is opened, and the fluid is stored in the height control accumulator.

When the vehicle height is raised while the fluid that is stored in the height control accumulator has not reached a prescribed pressure, only the fluid that is discharged by the pump is used for raising the vehicle height, without using the fluid in the height control accumulator.

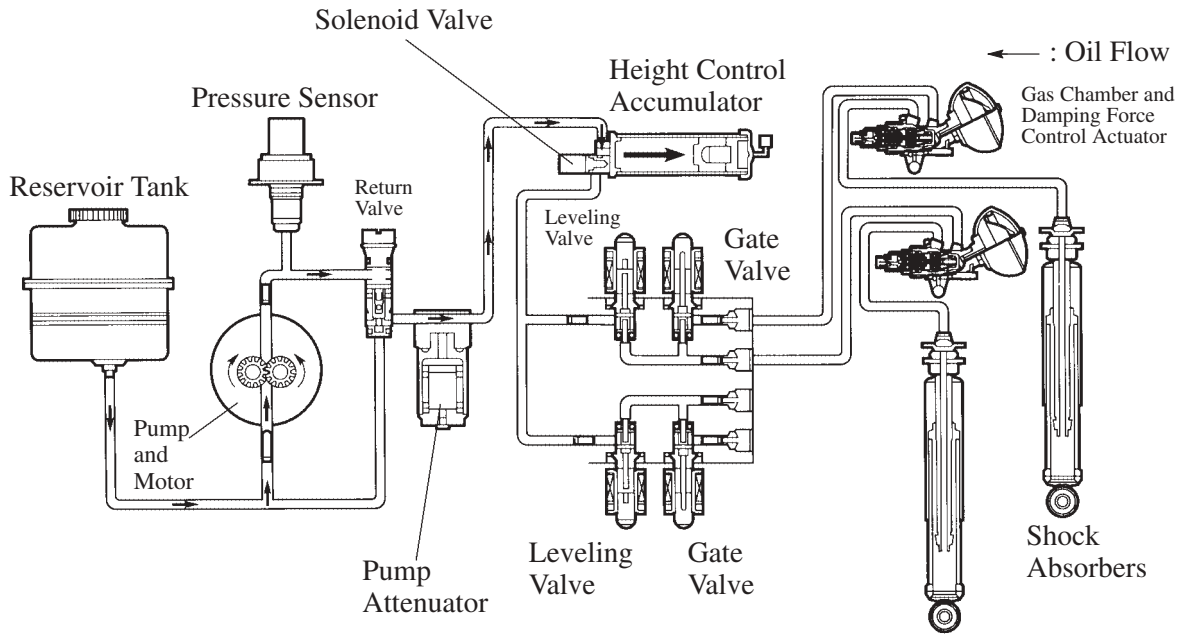

155CH87

Control Valve Assembly	Front	Leveling Valve	Close
		Gate Valve	Open
	Rear	Leveling Valve	Close
		Gate Valve	Open
Height Control Accumulator Solenoid Valve			Open
Pump and Motor			Operation

Lowering the Vehicle Height

1) Vehicle Speed Under 5 km/h (3 mph)

When the height select switch is operated to lower the vehicle height from high to normal, or from normal to low, the front and rear leveling valves are opened simultaneously to allow the fluid in the gas chambers and the shock absorbers at the 4 wheels to return to the reservoir tank, causing the height of the suspension at all 4 wheels to become lowered at the same time.

However, if the rear side is expected to become lower more quickly due to the load condition, and the difference between the lowering of the front side and the rear side becomes greater than a prescribed value, the rear leveling valve closes once, allowing only the vehicle height to become lowered at the front side. This feature prevents the headlights from being aimed upward.

2) Vehicle Speed Over 5 km/h (3 mph)

When the height select switch is operated to lower the vehicle height from high to normal, the front and rear leveling valves are opened alternately to lower the suspension of the front wheels and the rear wheels alternately.

When the vehicle speed is higher than approximately 5 km/h (3 mph), the vehicle height will not be lowered from normal to low.

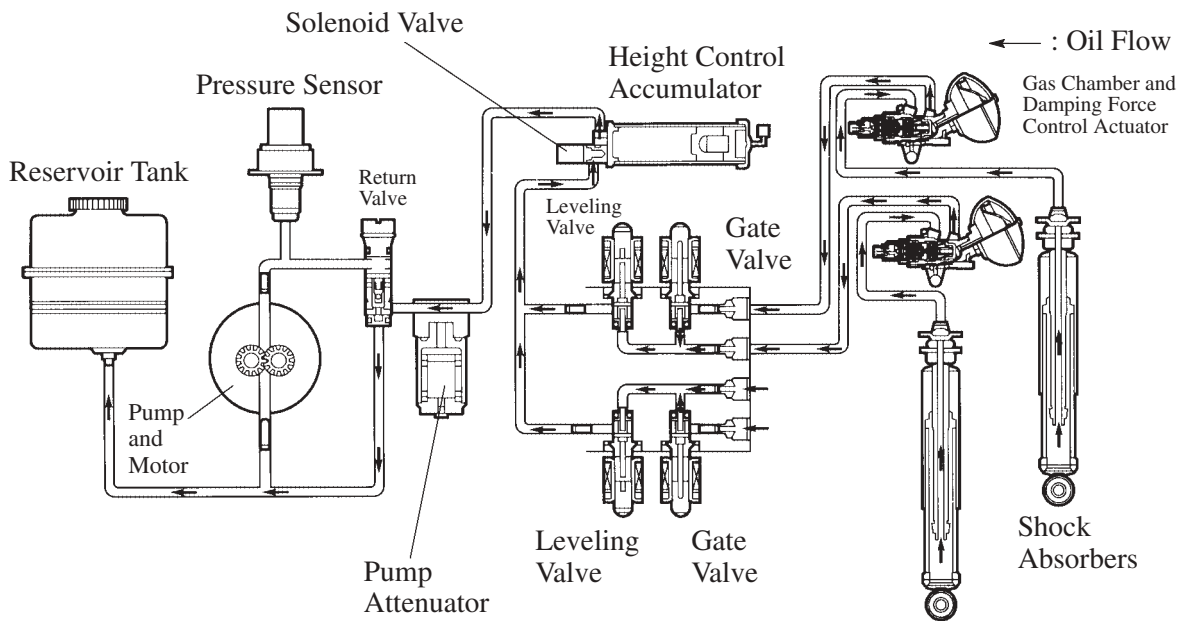

155CH88

Condition			Under 5 km/h (3 mph)		Over 5 km/h (3 mph)
			When lowering the four wheels simultaneously	Except lowering the four wheels simultaneously	
Control Valve Assembly	Front	Leveling Valve	Open	Open or Close	Open and Close
		Gate Valve	Open	Open	Open
	Rear	Leveling Valve	Open	Open or Close	Open and Close
		Gate Valve	Open	Open	Open
Height Control Accumulator Solenoid Valve			Close	Close	Close
Pump and Motor			Stop	Stop	Stop