

51. Install the pin.

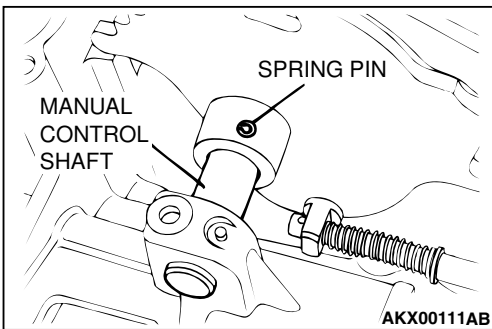

52. Hammer in so that the slit section of the spring valve is perpendicular to the axial direction of the manual control shaft.

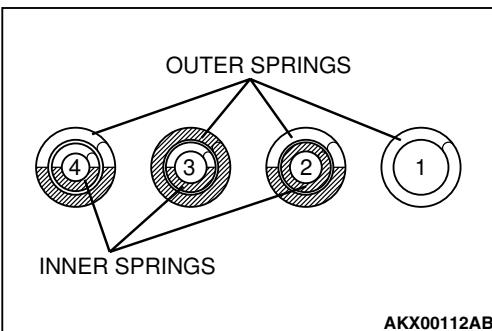

53. Install a new seal ring onto each accumulator piston.

54. Install each accumulator piston, spring and snap ring , accumulator cover, and O-ring .

NOTE: Identification colors are applied on the spring as shown below. Assemble following this table.

NOTE: Install the accumulator pistons to the original positions following the identification tags attached when removed.

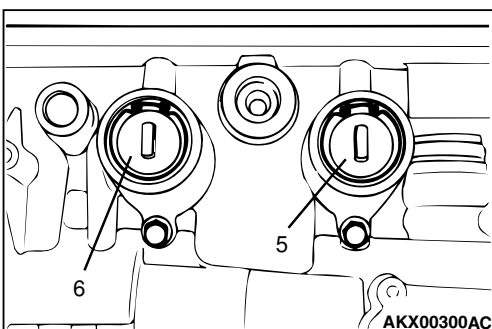
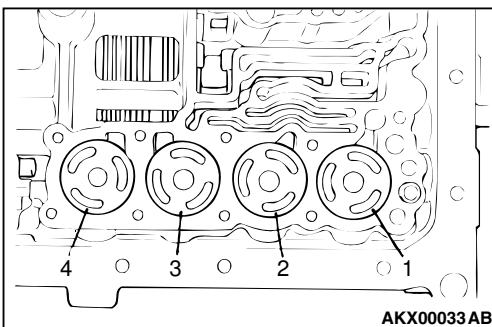

NO.	NAME	IDENTIFICATION PAINT APPLICATION POSITION	
1	For overdrive clutch	None	
2	For second brake	Inner	Applied on all surfaces including both ends
		Outer	Applied on half of surface including both ends
3	For low/reverse brake	Inner	Applied on half of surface including both ends
		Outer	Applied on entire surface of one side
4	For underdrive clutch	Inner	Applied on half of surface including both ends
		Outer	Applied on half of surface including both ends
5	For reduction brake	None	
6	For direct clutch	None	