



Workshop Manual

electrical wiring

SUPPLEMENT

PAJERO SPORT 2000

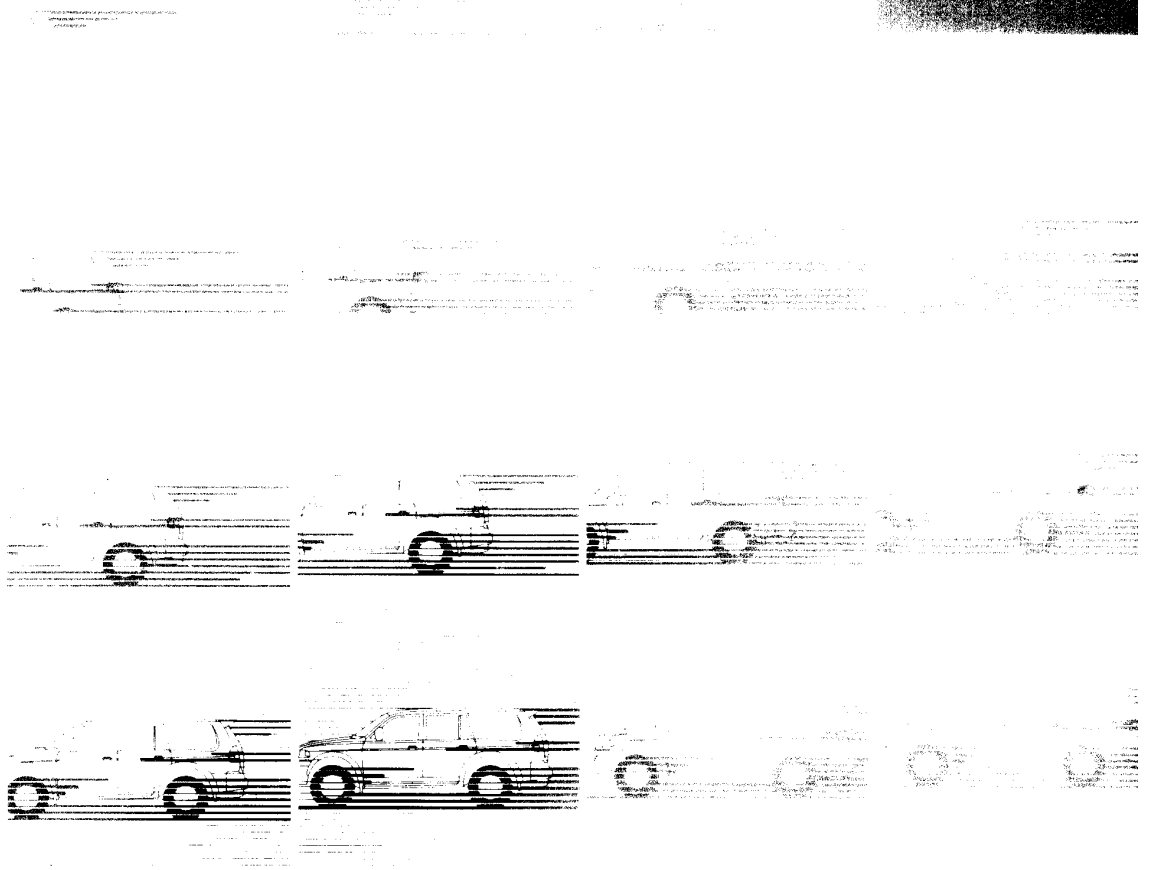
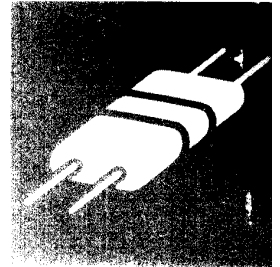

Pub. No. PHJE9810-A

PAJERO SPORT

ELECTRICAL WIRING SUPPLEMENT

FOREWORD

This publication is a supplement to the Electrical Wiring Manual Pub. No. PHJE9810 and contains only additions and changes to the original issue. It is recommended that all service mechanics engaged in the servicing of the vehicle refer to the following publications as well as this manual.

TECHNICAL INFORMATION MANUAL	
PYJE9804 (Basic)	
PYJE9804-A (Supplement)	
WORKSHOP MANUAL	
CHASSIS GROUP	
PWJE9812 (Basic)	
PWJE9812-A (Supplement)	
BODY REPAIR MANUAL	
PBJE9808	
ENGINE GROUP	
PWEE□□	
ELECTRICAL WIRING	
PHJE9810 (Basic)	
PARTS CATALOGUE	
B603D509A□	

All information, illustrations and product descriptions contained in this manual are current as of time of publication. We, however, reserve the right to make changes at any time without prior notice or obligation.

GROUP INDEX

OUTLINE OF CHANGES

WIRING HARNESS
CONFIGURATION DIAGRAMS

SINGLE PART INSTALLATION
POSITION

CIRCUIT DIAGRAM

2

3

4

 **MITSUBISHI MOTORS CORPORATION**

WARNINGS REGARDING SERVICING OF SUPPLEMENTAL RESTRAINT SYSTEM (SRS) EQUIPPED VEHICLE

WARNING!

- (1) Improper service or maintenance of any component of the SRS or any SRS-related component, can lead to personal injury or death to service personnel (from inadvertent firing of the air bag) or to the driver and passenger (from rendering the SRS inoperative).
- (2) SRS components should not be subjected to heat over 93 °C, so remove the SRS-ECU, air bag module (driver's side and front passenger's side) and clock spring before drying or baking the vehicle after painting.
- (3) Service or maintenance of any SRS component or SRS-related component must be performed only at an authorized MITSUBISHI dealer.
- (4) MITSUBISHI dealer personal must thoroughly review this manual, and especially its GROUP 52B-Supplemental Restraint System (SRS), before beginning any service or maintenance of any component of the SRS or any SRS-related component.

HOW TO USE THIS MANUAL

CONTENTS

The preceding page contains GROUP INDEX that lists the group title and group number.

PAGE NUMBERS

All page numbers consist of two sets of digits separated by a dash. The digits preceding the dash identify the number of the group. The digits following the dash represent the consecutive page number within the group. The page number can be found on the top left or right of each page.

OUTLINE OF CHANGES

CONTENTS

MODELS	2	WIRING HARNESS CONFIGURATION DIAGRAMS	9
ABBREVIATION SYMBOLS	2	SINGLE PART INSTALLATION POSITION	12
HOW TO READ CONFIGURATION DIAGRAMS	3	CIRCUIT DIAGRAMS	13
HOW TO READ CIRCUIT DIAGRAMS	4	TABLE OF CIRCUIT DIAGRAMS	17
MARKINGS FOR CONNECTOR EARTHING	6		

MODELS

Model code		Engine model	Transmission model	Fuel supply system
K96WG	RHEL6*	6G72-SOHC (2,972 ml)	V4A51 (4WD-4A/T)	MPI
	RHER6*		V5MT1 (4WD-5M/T)	
	NHEL6			
	NHER6			
K94W	NUFL6	4D56 (2,477 ml)		Fuel injection
	NUFR6			
K94WG	NHFL6			
	NHFR6			

NOTE

*: Indicates new model

ABBREVIATION SYMBOLS

The abbreviation symbols used diagrams are defined below.

1. Abbreviation symbols used for system name

Abbreviation symbol	Meaning	Abbreviation symbol	Meaning
A/T	Automatic transmission	INVECS-II	Intelligent and innovative vehicles electronic control system

2. Abbreviation symbol used for combination meters

Abbreviation symbol	Meaning
A/T TEMP	Automatic transmission fluid temperature warning lamp

HOW TO READ CONFIGURATION DIAGRAMS

The wiring harness diagrams clearly show the connector locations and harness routings at each site on actual vehicles.

Denotes connector No.
The same connector No. is used throughout the circuit diagrams to facilitate connector location searches.
The first alphabetical symbol indicates the location site of the connector and a number that follows is the unique number. Numbers are assigned to parts in clockwise order on the diagram.

Example: A-12

- Number specific to connector (serial number)
- Connector location site symbol

- A: Engine compartment
- B: Transmission
- C: Dash panel
- D: Steering column, junction block and relay box
- E: Floor and roof
- F: Door
- G: Tailgate

Denotes earth point.
Same earth number is used throughout circuit diagrams to facilitate search of earth point. Refer to GROUP 3 SINGLE PART INSTALLATION POSITION – EARTH MOUNTING LOCATIONS for details of earth points.

Denotes a section covered by a corrugated tube.

The mark ★ shows the standard mounting position of wiring harness.

Denotes the colour of corrugated tube. (If not specified, it is black.)
R: Red
Y: Yellow

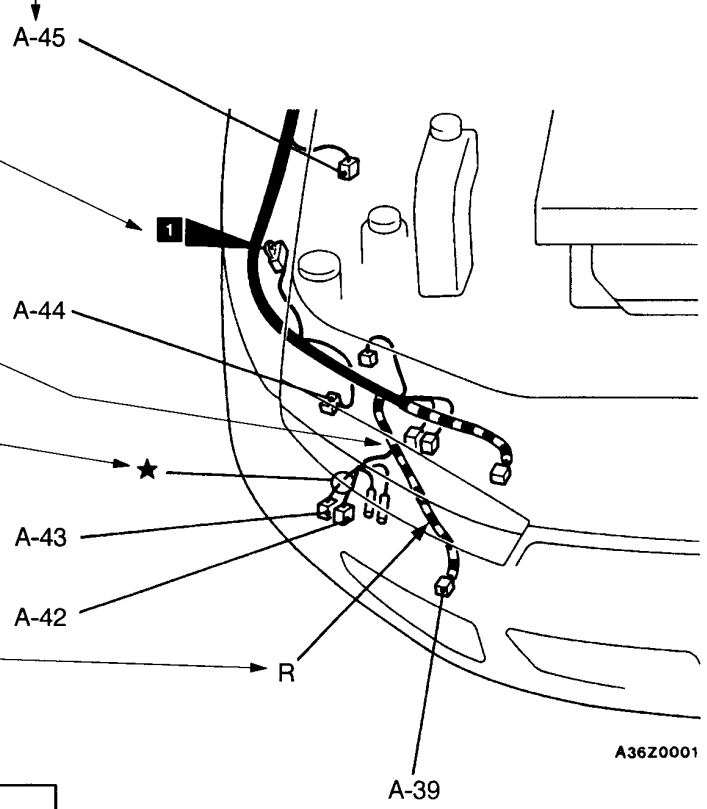

A36Z0001

The number of connector pins and the connector colour (except milk white)* are shown for ease of retrieval.

Example: (2-B)

- Connector colour (milk white if no colour is indicated)
- Number of connector pins

*: Typical connector colours

B: Black	BR: Brown
Y: Yellow	V: Violet
L: Blue	O: Orange
G: Green	GR: Gray
R: Red	None: Milk white

- A-39 (2-B) Headlamp (LO: RH)
- A-40 (1) Horn (LO)
- A-41 (1) Horn (HI)
- A-42 (2-B) Windshield washer motor

Indicates the device to which the connector is to be connected.

HOW TO READ CIRCUIT DIAGRAMS

The circuit of each system from fuse (or fusible link) to earth is shown. The power supply is shown at the top and the earth at the bottom to facilitate understanding of the current flow.

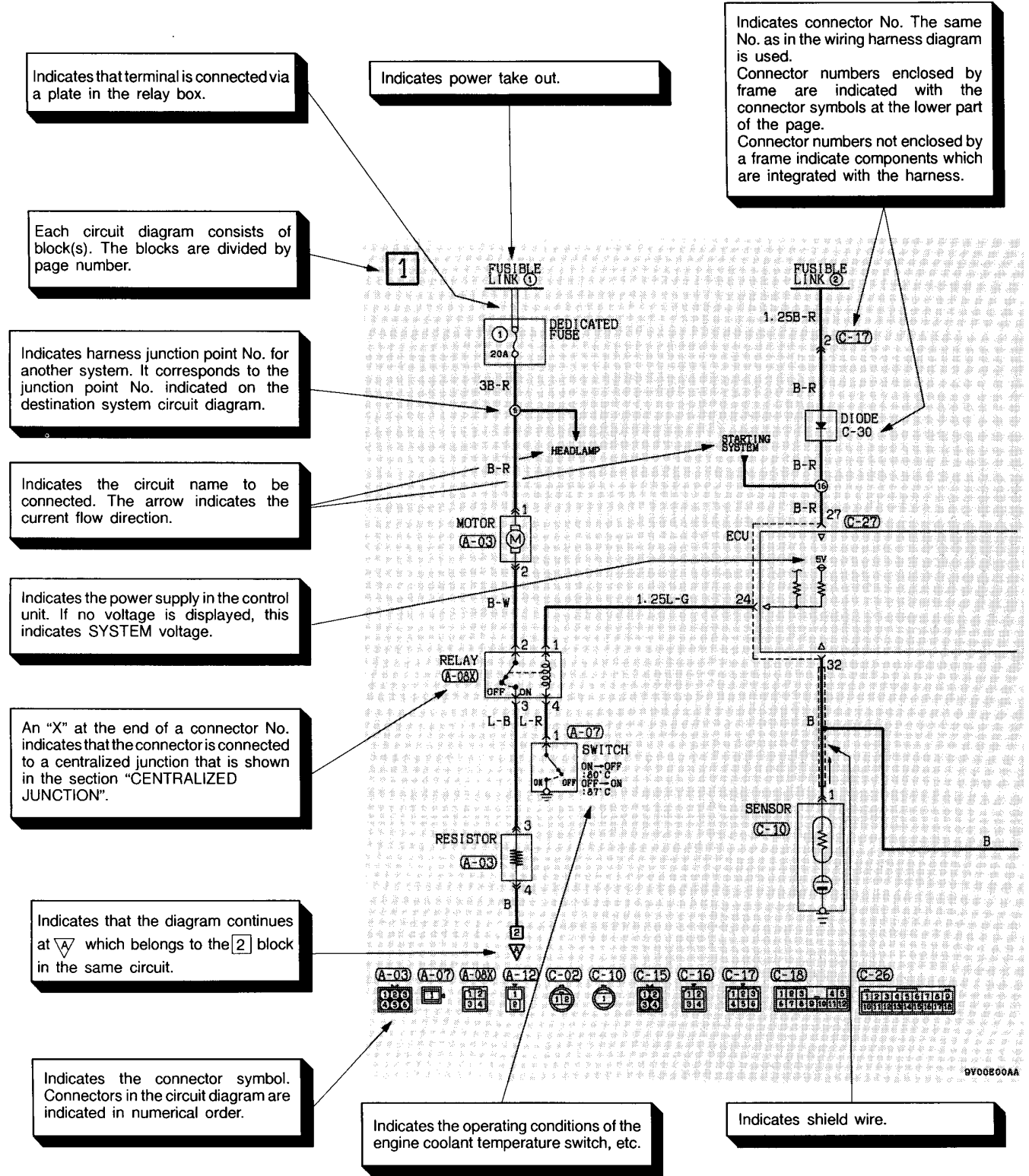

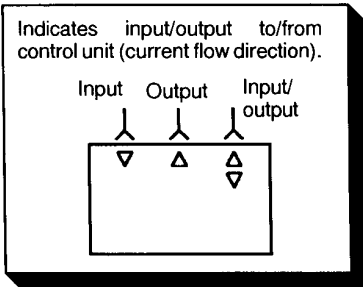

A broken line indicates that these connectors are the same intermediate connectors.

Indicates that the diagram comes from which belongs to the block in the same circuit.

Indicates terminal No.

In case two or more connectors are connected to the same device, markings indicating the same connectors are connected by a broken line.

Indicates current flow downward or upward as controlled by the control unit.

Indicates harness junction where wire diameter or colour changes.

Indicates intersections at which the lead wire are not connected.

Indicates intersections at which the lead wires are connected.

Indicates vehicle body earth point. (Same No. as that of earth point in wiring harness diagram and installation locations of individual parts.)



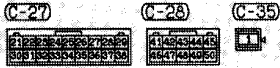
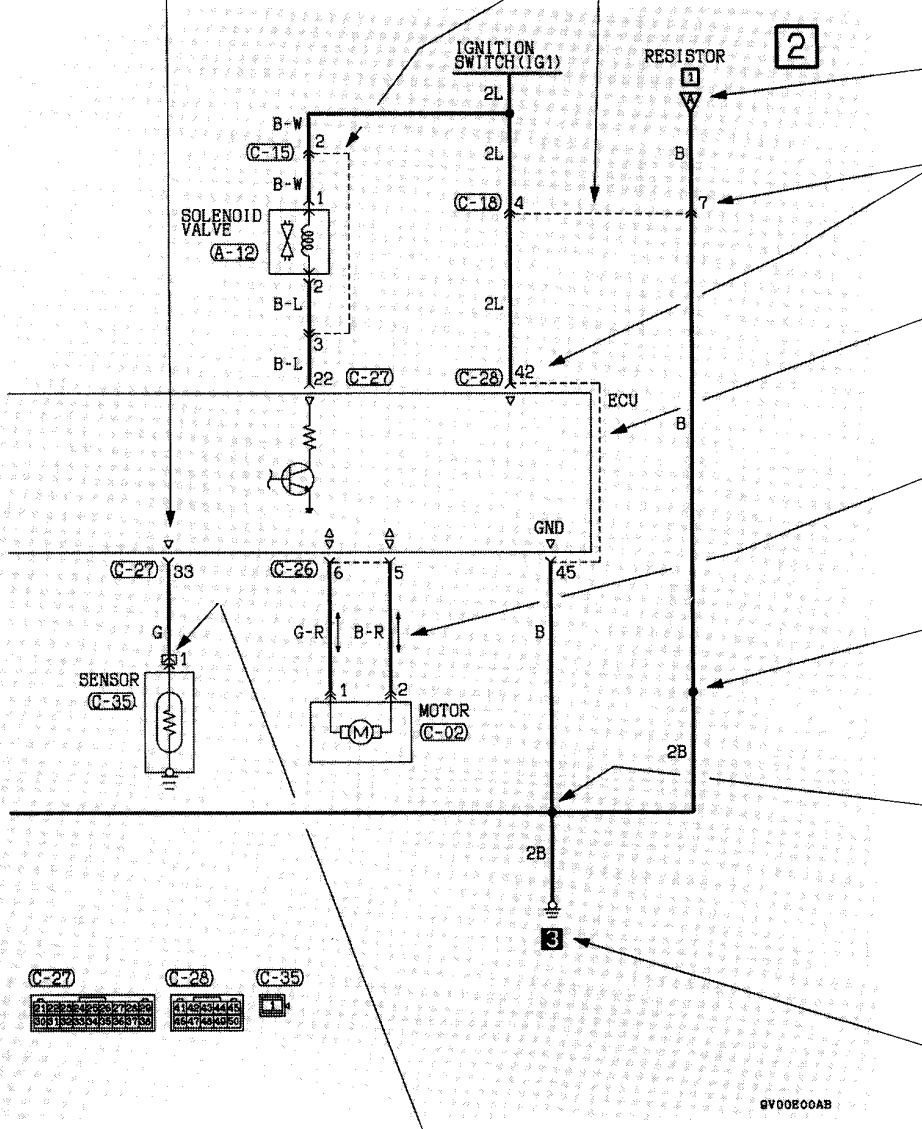

Indicates that the terminal is a spare one if the device (sensors in this case) is not provided.



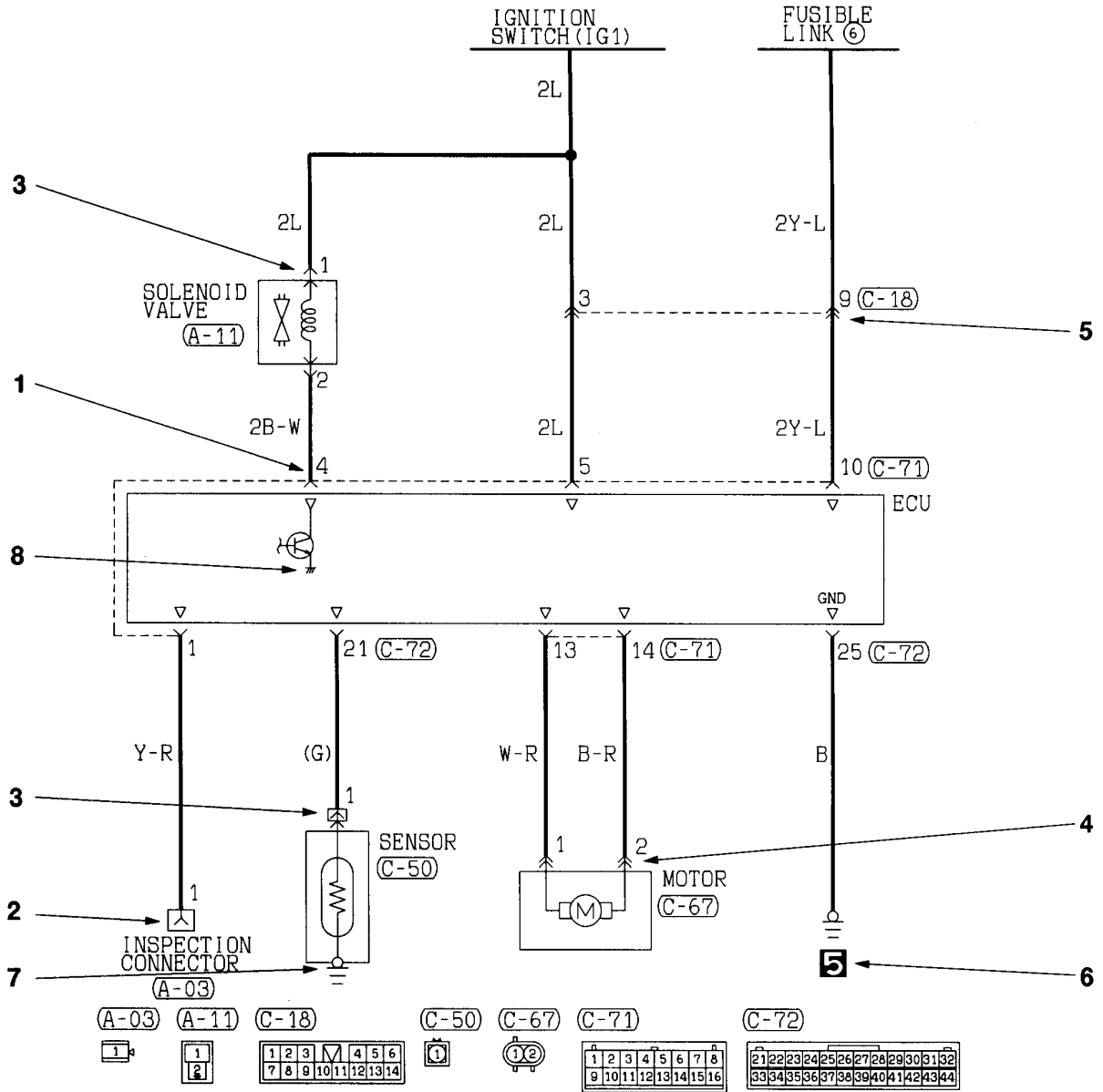

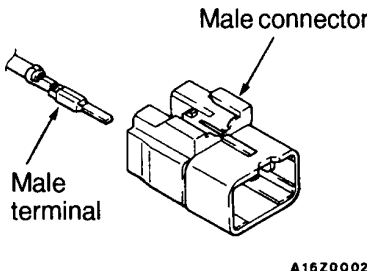

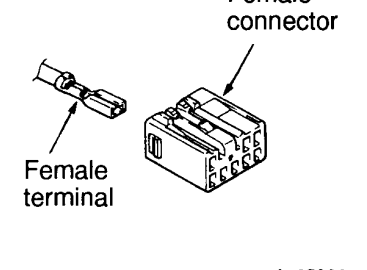

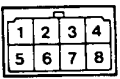
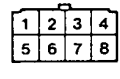
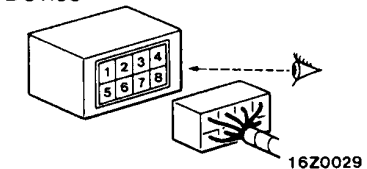
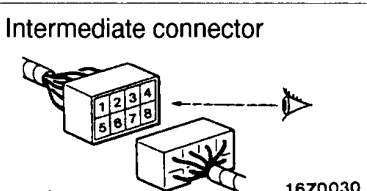
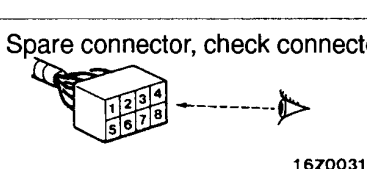
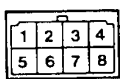
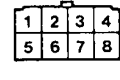

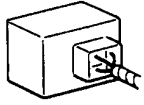
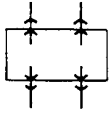
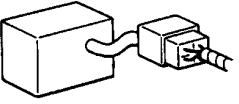
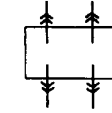
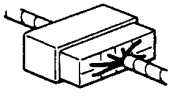
QV00R00AB

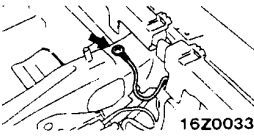
MARKINGS FOR CONNECTOR EARTHING

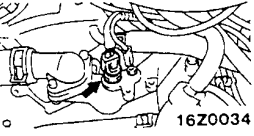

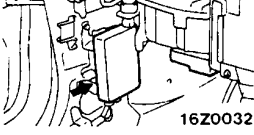
Item	No.	Connector/Earthing	Symbol	Contents
Connector and terminal marking	1		<p>Male terminal</p>  16Z0021	<p>The male and female terminals are indicated as shown. The connector with male terminal(s) is called as male connector and indicated by double connector contour lines, while the connector with female terminal(s) is called as female connector and indicated by single connector contour line.</p>
	-		<p>Female terminal</p>  16Z0022	
	-		<p>Male connector</p>  16Z0016	
	-		<p>Female connector</p>  16Z0017	
Connector symbol marking	2	<p>Device</p>  <p>Intermediate connector</p>  <p>Spare connector, check connector</p> 	 16Z0016	<p>The symbol indicates the vehicle connector as viewed from the illustrated direction. At the connection with a device, the connector symbol on the device side is shown, and for an intermediate connector, a male connector symbol is shown. For spare connectors and check connectors, no device is connected, and so the harness-side connector symbol is shown for these connectors. The details for the diagnosis connector differ from the above description. For details, refer to the "MUT-II operation instructions".</p>  16Z0017

Item	No.	Connector/Earthing	Symbol	Contents
Connector connection marking	3	Direct connection type  16Z0026	 16Z0023	A connection between a device and connector on the harness side is either by direct insertion in the device (direct connection type) or by connection with a harness connector on the device side furnished (harness connection type). The two types are indicated as illustrated.
	4	Harness connection type  16Z0027	 16Z0024	
	5	Intermediate connector  16Z0028	 16Z0025	
Earth markings	6	Body earth  16Z0033	 16Z0018	Earth is either by body earth, device earth or control unit interior earth. These are indicated as illustrated.
	7	Device earth  16Z0034	 16Z0019	
	8	Earth in control unit  16Z0032	 16Z0020	

WIRING HARNESS CONFIGURATION DIAGRAMS

Connector symbol	Name		Reference page	Description of changes
<div style="border: 1px solid black; display: inline-block; padding: 2px;">A</div>	ENGINE COMPARTMENT	Petrol <L.H. drive vehicles>	2-2	<ul style="list-style-type: none"> ● Following connectors have been discontinued. <ul style="list-style-type: none"> ● Horn (LO) (A-36) ● Horn (HI) (A-49) ● Following connectors have been added. <ul style="list-style-type: none"> ● Starter relay (A-21X) ● Front wiring harness and fog lamp wiring harness combination (A-106) ● Position lamp (LH) connector (A-33) and position lamp (RH) connector (A-51) have been re-coloured from gray to milky white. ● Horn (LO) connector (A-35) and horn (HI) connector (A-41) have been re-coloured from milky white to black.
		Petrol <R.H. drive vehicles>	2-6	<ul style="list-style-type: none"> ● Front turn-signal lamp (LH) connector (A-37) and front turn-signal lamp (RH) connector (A-47) have been re-coloured from brown to black. ● Outside thermo sensor <Multi-meter> connector (A-38) has been re-coloured from black to gray. ● The mounting positions of the following connectors have been revised. <ul style="list-style-type: none"> ● Headlamp washer motor (A-88) ● Windshield washer motor (A-91)
		Diesel <L.H. drive vehicles>	2-10	<ul style="list-style-type: none"> ● Following connectors have been discontinued. <ul style="list-style-type: none"> ● Horn (LO) (A-36) ● Horn (HI) (A-49) ● Front wiring harness and fog lamp wiring harness combination connector (A-106) has been added. ● Position lamp (LH) connector (A-33) and position lamp (RH) connector (A-51) have been re-coloured from gray to milky white. ● Horn (LO) connector (A-35) and horn (HI) connector (A-41) have been re-coloured from milky white to black.
		Diesel <R.H. drive vehicles>	2-14	<ul style="list-style-type: none"> ● Front turn-signal lamp (LH) connector (A-37) and front turn-signal lamp (RH) connector (A-47) have been re-coloured from brown to black. ● Outside thermo sensor <Multi-meter> connector (A-38) has been re-coloured from black to gray. ● The mounting positions of the following connectors have been revised. <ul style="list-style-type: none"> ● Headlamp washer motor (A-88) ● Windshield washer motor (A-91)
<div style="border: 1px solid black; display: inline-block; padding: 2px;">B</div>	TRANSMISSION	–	2-18	<ul style="list-style-type: none"> ● The wiring harness configuration diagram for the 2000 model has been established.

Connector symbol	Name		Reference page	Description of changes
C	DASH PANEL	L.H. drive vehicles	2-20	<ul style="list-style-type: none"> ● Terminal numbers of the SRS-ECU connector (C-25) have been changed from 21 to 20. ● Terminal numbers of the front wiring harness and transmission wiring harness combination connector (C-31) have been changed from 5 to 7. ● Following connectors have been added. <ul style="list-style-type: none"> ● Diode (for sunroof circuit) (C-72) ● Combination meter (C-73) ● Hold switch <A/T> (C-74) ● Glove box lamp switch (C-75) ● Glove box lamp switch (C-76) ● Glove box lamp (C-77) ● Hazard warning relay (C-78) ● Body wiring harness and front wiring harness combination (C-79) ● Engine-A/T-ECU <Petrol-A/T> (C-81) ● Engine-A/T-ECU <Petrol-A/T> (C-82) ● Engine-A/T-ECU <Petrol-A/T> (C-83) ● Engine-A/T-ECU <Petrol-A/T> (C-84) ● Motor antenna (C-85) ● Antenna length sensor (C-86) ● A/T control relay (C-87) ● A/T selector lever position illumination lamp (C-88) ● Wide-open throttle switch <A/T> (C-89) ● Body wiring harness and transmission wiring harness combination (C-90) ● Front wiring harness and transmission wiring harness combination (C-91) ● Motor antenna-ECU (C-92) ● Engine-ECU <Petrol> connector (C-47) has been re-named to the engine-ECU <Petrol-M/T>. ● Engine-ECU <Petrol> connector (C-49) has been re-named to the engine-ECU <Petrol-M/T>. ● Engine-ECU <Petrol> connector (C-50) has been re-named to the engine-ECU <Petrol-M/T>. ● Engine-ECU <Petrol> connector (C-51) has been re-named to the engine-ECU <Petrol-M/T>. ● The mounting positions of the following connectors have been revised. <ul style="list-style-type: none"> ● Rear fog lamp relay (C-44) ● Defogger relay (C-65) ● Engine oil level relay <Petrol> (C-66) ● Engine oil level relay <Diesel> (C-67)

Connector symbol	Name		Reference page	Description of changes
<div style="border: 1px solid black; display: inline-block; padding: 2px;">C</div>	DASH PANEL	R.H. drive vehicles	2-24	<ul style="list-style-type: none"> ● Terminal numbers of the SRS-ECU (C-25) have been changed from 21 to 20. ● Terminal numbers of the front wiring harness and transmission wiring harness combination connector (C-31) have been changed from 5 to 7. ● Following connectors have been added. <ul style="list-style-type: none"> ● Diode (for sunroof circuit) (C-72) ● Combination meter (C-73) ● Hold switch <A/T> (C-74) ● Hazard warning relay (C-78) ● Body wiring harness and front wiring harness combination (C-79) ● Engine-A/T-ECU <Petrol-A/T> (C-81) ● Engine-A/T-ECU <Petrol-A/T> (C-82) ● Engine-A/T-ECU <Petrol-A/T> (C-83) ● Engine-A/T-ECU <Petrol-A/T> (C-84) ● Motor antenna (C-85) ● Antenna length sensor (C-86) ● A/T control relay (C-87) ● A/T selector lever position illumination lamp (C-88) ● Wide-open throttle switch <A/T> (C-89) ● Body wiring harness and transmission wiring harness combination (C-90) ● Front wiring harness and transmission wiring harness combination (C-91) ● Motor antenna-ECU (C-92) ● Engine-ECU <Petrol> connector (C-47) has been re-named to the engine-ECU <Petrol-M/T>. ● Engine-ECU <Petrol> connector (C-49) has been re-named to the engine-ECU <Petrol-M/T>. ● Engine-ECU <Petrol> connector (C-50) has been re-named to the engine-ECU <Petrol-M/T>. ● Engine-ECU <Petrol> connector (C-51) has been re-named to the engine-ECU <Petrol-M/T>. ● The mounting positions of the following connectors have been revised. <ul style="list-style-type: none"> ● Rear fog lamp relay (C-44) ● Defogger relay (C-65) ● Engine oil level relay <Petrol> (C-66) ● Engine oil level relay <Diesel> (C-67)

Connector symbol	Name		Reference page	Description of changes
D	STEERING COLUMN, JUNCTION BLOCK AND RELAY BOX	L.H. drive vehicles	2-28	<ul style="list-style-type: none"> ETACS-ECU connector (D-30) has been re-named to the ETACS-ECU <Vehicles without keyless entry system>. ETACS-ECU <Vehicles with keyless entry system> connector (D-32) has been added.
		R.H. drive vehicles	2-30	
E	FLOOR AND ROOF	L.H. drive vehicles	2-32	<ul style="list-style-type: none"> Following connectors have been added. <ul style="list-style-type: none"> Keyless entry receiver-ECU (E-44) Accessory socket (2) (E-45) Accessory socket (2) (E-46) Motor antenna switch (E-47) Oxygen sensor (E-48)
		R.H. drive vehicles	2-34	
F	DOOR	L.H. drive vehicles	2-36	<ul style="list-style-type: none"> The mounting positions of the following connectors have been revised. <ul style="list-style-type: none"> Door lamp (LH) (F-12) Door lamp (RH) (F-26) Door lock key cylinder switch (LH) connector (F-06) has been discontinued.
		R.H. drive vehicles	2-38	

SINGLE PART INSTALLATION POSITION

Location of changes	Reference page	Description of changes
RELAY	3-2	<ul style="list-style-type: none"> Following relays have been added. <ul style="list-style-type: none"> A/T control relay Hazard warning relay <with keyless entry> The mounting positions of the defogger relay, rear fog lamp relay and engine oil level relay have been changed.
ECU	3-3	<ul style="list-style-type: none"> Following ECUs have been added. <ul style="list-style-type: none"> Engine-A/T-ECU Motor antenna-ECU Keyless entry receiver-ECU
SENSOR	3-4	<ul style="list-style-type: none"> Following sensors have been added. <ul style="list-style-type: none"> A/T fluid temperature sensor Antenna length sensor Input shaft speed sensor <A/T> Output shaft speed sensor <A/T> Oxygen sensor <A/T> Oxygen sensor <M/T>
SOLENOID VALVE	3-5	<ul style="list-style-type: none"> A/T control solenoid valve assembly has been added.
DIODE	3-5	<ul style="list-style-type: none"> Diode (for sunroof circuit) has been added.

CIRCUIT DIAGRAMS

Main title	Sub title	Reference page	Description of changes
JOINT CONNECTOR (J/C)	–	4-4	<ul style="list-style-type: none"> The circuit for the 2000 model has been established.
CENTRALIZED JUNCTION	–	4-8	<ul style="list-style-type: none"> Modifications have been made to correspond to the introduction of the INVECS-II A/T and the keyless entry system.
STARTING SYSTEM	M/T	4-12	<ul style="list-style-type: none"> The circuit has been newly established to correspond to the introduction of the INVECS-II A/T.
	A/T	4-13	
IGNITION SYSTEM	–	4-14	<ul style="list-style-type: none"> The circuit has been changed to correspond to the introduction of the INVECS-II A/T.
GLOW SYSTEM	–	4-15	<ul style="list-style-type: none"> The circuit has been changed to correspond to the change of the combination meter.
ENIGNE CONTROL SYSTEM	M/T	4-16	<ul style="list-style-type: none"> The circuit has been added to correspond to the introduction of the INVECS-II A/T.
	A/T	4-24	
	Diesel	4-32	<ul style="list-style-type: none"> Due to the change on the combination meter, the circuit has been changed.
INVECS-II 4A/T	–	4-34	<ul style="list-style-type: none"> The circuit has been added to correspond to the introduction of the INVECS-II A/T.
TAIL LAMP, POSITION LAMP AND LICENCE PLATE LAMP	L.H. drive vehicles	4-44	<ul style="list-style-type: none"> Due to the change on the body wiring harness and floor wiring harness combination (E-40), the circuit has been changed.
	R.H. drive vehicles	4-46	
FRONT FOG LAMP	L.H. drive vehicles	4-48	<ul style="list-style-type: none"> Due to the addition of connector (A-106) at the front wiring harness and fog lamp wiring harness combination, the circuit has been changed.
	R.H. drive vehicles	4-50	
REAR FOG LAMP	L.H. drive vehicles	4-52	<ul style="list-style-type: none"> The circuit has been revised as the body wiring harness/frame wiring harness combination connector (E-41) and the combination meter have been changed.
	R.H. drive vehicles	4-56	
GLOVE BOX LAMP	–	4-59	<ul style="list-style-type: none"> The circuit has been added due to the addition of the glove box lamp.
HEADLAMP LEVELING SYSTEM	–	4-60	<ul style="list-style-type: none"> The circuit has been changed as the mounting position of the headlamp leveling switch has been changed.
ROOM LAMP, MAP LAMP AND LUGGAGE COMPARTMENT LAMP	Vehicles with keyless entry system	4-62	<ul style="list-style-type: none"> The circuit has been changed to correspond to the addition of the keyless entry system.
	Vehicles without keyless entry system	4-66	
IGNITION KEY CYLINDER ILLUMINATION LAMP	L.H. drive vehicles	4-68	<ul style="list-style-type: none"> The circuit has been changed as the body wiring harness/floor wiring harness combination connector (E-40) has been changed and keyless entry system has been added.
	R.H. drive vehicles	4-69	

Main title	Sub title	Reference page	Description of changes
DOOR LAMP	L.H. drive vehicles	4-70	<ul style="list-style-type: none"> The circuit has been added as the body wiring harness/floor wiring harness combination connector (E-40) has been changed and the diode has been added.
	R.H. drive vehicles	4-71	
TURN-SIGNAL LAMP AND HAZARD WARNING LAMP	–	4-72	<ul style="list-style-type: none"> The circuit has been changed as the body wiring harness/floor wiring harness combination connector (E-40) has been changed and the keyless entry system has been added.
STOP LAMP	–	4-74	<ul style="list-style-type: none"> The circuit has been changed due to the change on body wiring harness and floor wiring harness combination connector (E-40).
BACK-UP LAMP	–	4-76	<ul style="list-style-type: none"> The circuit has been changed to correspond to the introduction of the INVECS-II A/T system.
HORN	–	4-77	<ul style="list-style-type: none"> The circuit has been changed due to the change on the horns (LO and HI).
METER AND GAUGE	–	4-78	<ul style="list-style-type: none"> The circuit has been changed as body wiring harness/transmission wiring harness combination connector (C-30) and body wiring harness/frame wiring harness combination connector (E-41) have been revised.
BRAKE WARNING LAMP	–	4-82	<ul style="list-style-type: none"> The circuit has been changed as body wiring harness/frame wiring harness combination connector (E-41) has been changed.
FUEL WARNING LAMP	–	4-82	
OIL PRESSURE WARNING LAMP	–	4-83	
FUEL FILTER WARNING LAMP	–	4-83	
CENTRAL DOOR LOCKING SYSTEM	L.H. drive vehicles with keyless entry system	4-84	<ul style="list-style-type: none"> The circuit has been added due to the addition of the keyless entry system.
	L.H. drive vehicles without keyless entry system	4-94	
	R.H. drive vehicles with keyless entry system	4-98	
	R.H. drive vehicles without keyless entry system	4-108	
POWER WINDOWS	–	4-112	<ul style="list-style-type: none"> The circuit has been changed as body wiring harness/floor wiring harness combination connector (E-39) has been changed.
HEATER	Petrol-powered vehicles	4-116	<ul style="list-style-type: none"> The circuit for the 2000 models has been added.
	Diesel-powered vehicles	4-118	

Main title	Sub title	Reference page	Description of changes
AIR CONDITIONER	Petrol-powered vehicles	4-120	<ul style="list-style-type: none"> The circuit has been changed due to the introduction of the INVECS-II A/T system and the change on J/C (4).
	Diesel-powered vehicles	4-124	<ul style="list-style-type: none"> The circuit has been changed due to the change on J/C (4).
REAR HEATER	–	4-128	<ul style="list-style-type: none"> The circuit has been changed as body wiring harness/floor wiring harness combination connector (C-39) and body wiring harness/floor wiring harness combination connector (C-40) have been changed.
HEADLAMP WASHER	–	4-134	<ul style="list-style-type: none"> The circuit has been changed due to the change on J/C (4).
RADIO AND TAPE PLAYER	–	4-136	<ul style="list-style-type: none"> The circuit has been changed due to the addition of the motor antenna.
ACCESSORY SOCKET	–	4-139	<ul style="list-style-type: none"> The circuit has been changed due to the change on J/C (4).
ANTI-SKID BRAKING SYSTEM (ABS)	–	4-140	<ul style="list-style-type: none"> The circuit has been changed as body wiring harness/transmission wiring harness combination connector (C-30) and body wiring harness/frame wiring harness combination connector (C-41) have been changed.
SUPPLEMENTAL RESTRAINT SYSTEM (SRS)	–	4-146	<ul style="list-style-type: none"> The circuit has been changed due to the change on the SRS-ECU.
AUTO-CRUISE CONTROL SYSTEM	–	4-148	<ul style="list-style-type: none"> The circuit has been changed as body wiring harness/transmission wiring harness combination connector (C-30) has been changed and the INVECS-II A/T has been introduced.
PART TIME 4WD SYSTEM	–	4-154	<ul style="list-style-type: none"> The circuit has been changed as body wiring harness/transmission wiring harness combination connector (C-30) has been changed.
SUNROOF	–	4-156	<ul style="list-style-type: none"> The circuit has been changed as body wiring harness/floor wiring harness combination connector (E-40) has been changed and a diode has been added.
IMMOBILIZER SYSTEM	Petrol-powered vehicles	4-158	<ul style="list-style-type: none"> The circuit has been changed due to the introduction of the INVECS-II A/T system.
LIGHTING MONITOR BUZZER	L.H. drive vehicles	4-160	<ul style="list-style-type: none"> The circuit has been changed due to the change on body wiring harness/floor wiring harness combination connector (E-40) and the addition of the keyless entry system.
	R.H. drive vehicles	4-162	
HEATED SEAT	–	4-164	<ul style="list-style-type: none"> The circuit has been changed due to the change on the heated seat switch.
RHEOSTAT	–	4-166	<ul style="list-style-type: none"> The circuit has been changed due to the introduction of the INVECS-II A/T system.

Main title	Sub title	Reference page	Description of changes
FUEL LINE HEATER	–	4-167	<ul style="list-style-type: none">• The circuit has been changed due to the change on J/C (4).
INTERCOOLER FAN	–	4-168	<ul style="list-style-type: none">• The circuit has been changed due to the change on body wiring harness/transmission wiring harness combination connector (C-30).

TABLE OF CIRCUIT DIAGRAMS

This table of circuit diagrams indicates those circuits in which changes and/or additions, etc. have been made; the circuits are here listed in the sequence in which they are presented in the wiring diagrams. Please use this table for reference when following maintenance or repair procedures.

NOTE

- (1) A (Added) : This circuit has been newly added.
- (2) R (Revised) : This circuit has been changed.
- (3) D (Deleted) : This circuit has been deleted.
- (4) I (Included) : This circuit is included in the previous manual(s).
- (5) N (Not applicable) : This circuit is not applicable.
- (6) P (Previous manual) : This circuit is not included, because it has not been changed.
Refer to the previous manual(s).

Main circuit	Circuit classifications	Previous manual: Pub. No. PHJE9810 (Basic)	This manual:Pub. No. PHJE9810-A (Supplement)
JUNCTION BLOCK (J/B)	–	I	P
JOINT CONNECTOR (J/C)	–	I	R
CENTRALIZED JUNCTION	–	I	R
POWER DISTRIBUTION SYSTEM	L.H. drive vehicles	I	P
	R.H. drive vehicles	I	P
STARTING SYSTEM	–	I	D
	M/T	N	A
	A/T	N	A
IGNITION SYSTEM	–	I	R
CHARGING SYSTEM	Petrol-powered vehicles	I	P
	Diesel-powered vehicles	I	P
GLOW-SYSTEM	–	I	R
ENGINE CONTROL SYSTEM	–	I	D
	MPI-M/T	N	A
	MPI-A/T	N	A
	Diesel	I	R
INVECS-II 4A/T	–	N	A
HEADLAMP	L.H. drive vehicles with daytime running lamp	I	P
	L.H. drive vehicles without daytime running lamp	I	P
	R.H. drive vehicles	I	P

Main circuit	Circuit classifications	Previous manual: Pub. No. PHJE9810 (Basic)	This manual:Pub. No. PHJE9810-A (Supplement)
TAIL LAMP, POSITION LAMP AND LICENCE PLATE LAMP	L.H. drive vehicles	I	R
	R.H. drive vehicles	I	R
FRONT FOG LAMP	L.H. drive vehicles	I	R
	R.H. drive vehicles	I	R
REAR FOG LAMP	L.H. drive vehicles	I	R
	R.H. drive vehicles	I	R
GLOVE BOX LAMP	–	N	A
HEADLAMP LEVELING SYSTEM	–	I	R
ROOM LAMP, MAP LAMP AND LUGGAGE COMPARTMENT LAMP	–	I	D
	Vehicles with keyless entry system	N	A
	Vehicles without keyless entry system	N	A
IGNITION KEY CYLINDER ILLUMINATION LAMP	L.H. drive vehicles	I	R
	R.H. drive vehicles	I	R
DOOR LAMP	–	I	D
	L.H. drive vehicles	N	A
	R.H. drive vehicles	N	A
TURN-SIGNAL LAMP AND HAZARD WARNING LAMP	–	I	R
STOP LAMP	–	I	R
BACK-UP LAMP	–	I	R
HORN	–	I	R
METER AND GAUGE	–	I	R
BRAKE WARNING LAMP	–	I	R
FUEL WARNING LAMP	–	I	R
OIL PRESSURE WARNING LAMP	–	I	R
FUEL FILTER WARNING LAMP	–	I	R

Main circuit	Circuit classifications	Previous manual: Pub. No. PHJE9810 (Basic)	This manual:Pub. No. PHJE9810-A (Supplement)
ENGINE OIL LEVEL WARNING LAMP	Petrol-powered vehicles	I	P
	Diesel-powered vehicles	I	P
MULTI-METER	–	I	P
CENTRAL DOOR LOCKING SYSTEM	L.H. drive vehicles	I	D
	R.H. drive vehicles	I	D
	L.H. drive vehicles with keyless entry system	N	A
	L.H. drive vehicles without keyless entry system	N	A
	R.H. drive vehicles with keyless entry system	N	A
	R.H. drive vehicles without keyless entry system	N	A
POWER WINDOWS	–	I	R
HEATER	–	I	D
	Petrol-powered vehicles	N	A
	Diesel-powered vehicles	N	A
AIR CONDITIONER	Petrol-powered vehicles	I	R
	Diesel-powered vehicles	I	R
REAR HEATER	–	I	R
WINDSHIELD WIPER AND WASHER	–	I	P
REAR WIPER AND WASHER	–	I	R
HEADLAMP WASHER	–	I	R
REAR WINDOW DEFOGGER, DOOR MIRROR HEATER AND WIPER DEICER	–	I	P
REMOTE CONTROLLED MIRROR	L.H. drive vehicles	I	P
	R.H. drive vehicles	I	P
RADIO AND TAPE PLAYER	–	I	R
CLOCK	L.H. drive vehicles	I	P
	R.H. drive vehicles	I	P
CIGARETTE LIGHTER	–	I	P

Main circuit	Circuit classifications	Previous manual: Pub. No. PHJE9810 (Basic)	This manual:Pub. No. PHJE9810-A (Supplement)
ACCESSORY SOCKET	–	I	R
ANTI-SKID BRAKING SYSTEM (ABS)	–	I	R
SUPPLEMENTAL RESTRAINT SYSTEM (SRS)	–	I	R
AUTO-CRUISE CONTROL SYSTEM	–	I	R
PART TIME 4WD SYSTEM	–	I	R
SUNROOF	–	I	R
IMMOBILIZER SYSTEM	Petrol-powered vehicles	I	R
	Diesel-powered vehicles	I	P
LIGHTING MONITOR BUZZER	L.H. drive vehicles	I	R
	R.H. drive vehicles	I	R
HEATED SEAT	–	I	R
RHEOSTAT	–	I	R
FUEL LINE HEATER	–	I	R
INTERCOOLER FAN	–	I	R

WIRING HARNESS CONFIGURATION DIAGRAMS

CONTENTS

ENGINE COMPARTMENT

Petrol <L.H. drive vehicles>	2-2
Petrol <R.H. drive vehicles>	2-6
Diesel <L.H. drive vehicles>	2-10
Diesel <R.H. drive vehicles>	2-14

TRANSMISSION

2-18

DASH PANEL

L.H. drive vehicles	2-20
R.H. drive vehicles	2-24

STEERING COLUMN, JUNCTION BLOCK AND RELAY BOX

L.H. drive vehicles	2-28
R.H. drive vehicles	2-30

FLOOR AND ROOF

L.H. drive vehicles	2-32
R.H. drive vehicles	2-34

DOOR

L.H. drive vehicles	2-36
R.H. drive vehicles	2-38

ENGINE COMPARTMENT

Petrol <L.H. drive vehicles>

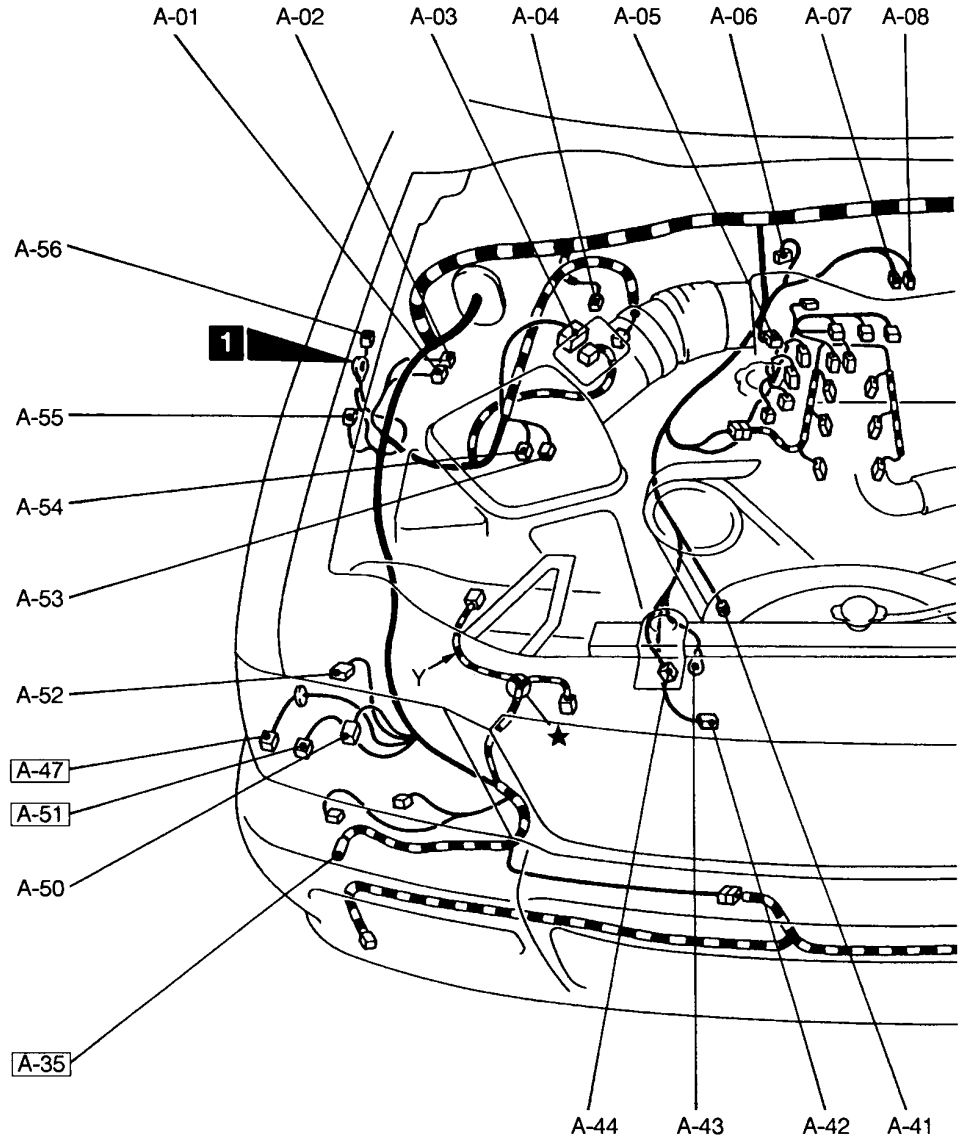
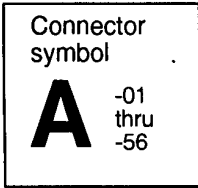

- | | | | |
|-------------|----------------------------------|-------------|---|
| A-01 (26-B) | ABS-ECU | A-21X (5) | Starter relay <A/T> |
| A-02 (4-GR) | ABS-ECU | A-23X (5) | Headlamp relay |
| A-03 (7-B) | Air flow sensor | A-24X (5) | Blower relay |
| A-04 (4-B) | Auto-cruise vacuum pump | A-25X (5) | Storage connector |
| A-05 (6-B) | Idle speed control servo | A-26X (4) | A/C compressor relay <A/C> |
| A-06 (4-B) | Throttle position sensor | A-27X (4) | Condenser fan relay <A/C> |
| A-07 (2-B) | Purge control solenoid valve | A-30 (10-B) | DRL wiring harness and front wiring harness combination |
| A-08 (2-BR) | EGR solenoid valve | A-31 (3) | Headlamp leveling unit (LH) |
| A-14 (2-B) | Brake fluid level switch | A-32 (10-B) | DRL wiring harness and front wiring harness combination |
| A-15 (4-B) | Windshield wiper motor | A-33 (2) | Position lamp (LH) |
| A-16 (2-B) | Wiper deicer | | |
| A-17 (1-L) | Engine speed detection connector | | |
| A-20X (4) | Alternator relay | | |

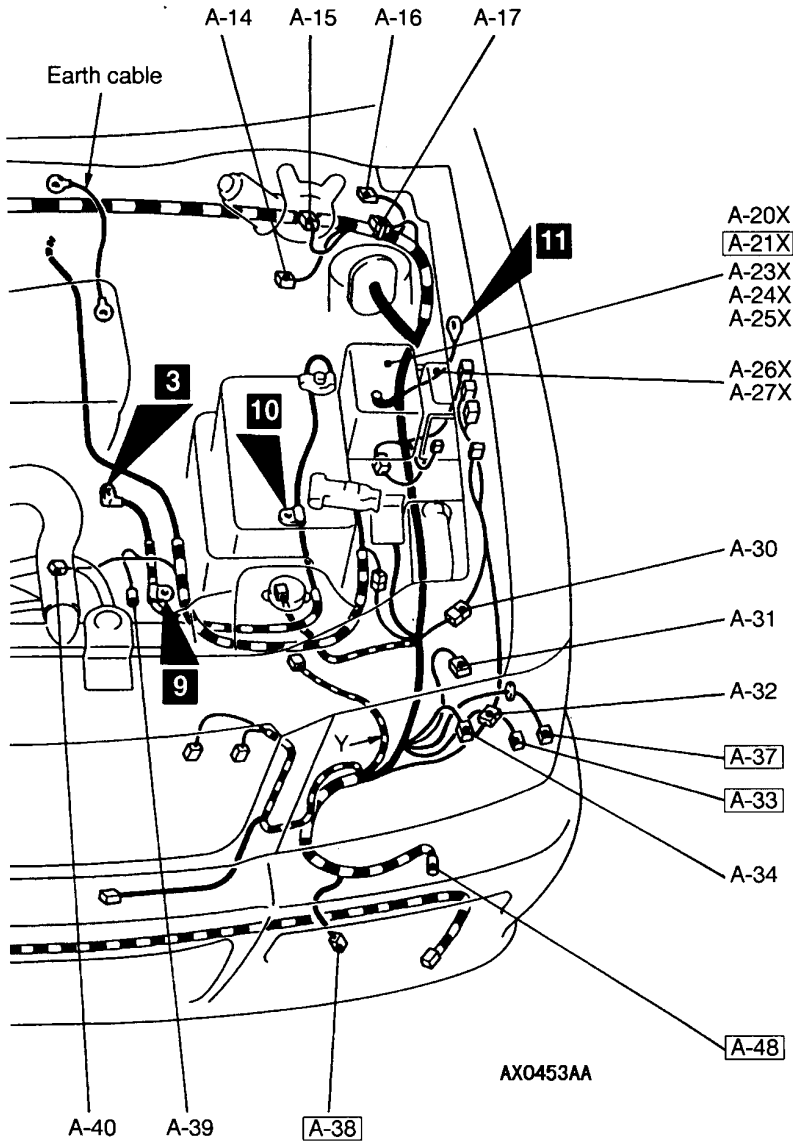

<Vehicles without DRL>

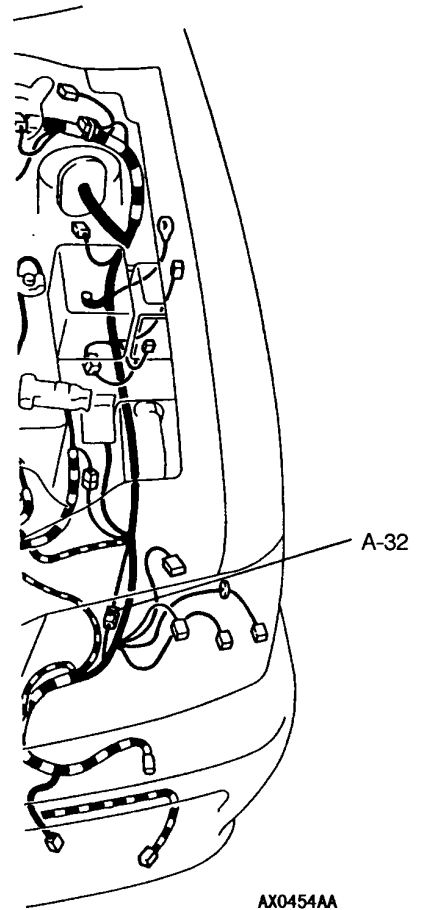

- A-34 (3-B) Headlamp (LH)
- A-35 (1-B) Horn (LO)
- A-37 (2-B) Front turn-signal lamp (LH)
- A-38 (2-BR) Outside thermo sensor <Multi-meter>
- A-39 (3-B) Magnetic clutch and refrigerant temperature switch
- A-40 (1-B) Oil pressure gauge unit
- A-41 (1) Power steering oil pressure switch
- A-42 (2-B) Engine oil level sensor
- A-43 (1) Alternator
- A-44 (2-B) Alternator
- A-47 (2-B) Front turn-signal lamp (RH)

- A-48 (1-B) Horn (HI)
- A-50 (3-B) Headlamp (RH)
- A-51 (2) Position lamp (RH)
- A-52 (3) Headlamp leveling unit (RH)
- A-53 (2-B) Solenoid valve A <4WD>
- A-54 (2-B) Solenoid valve B <4WD>
- A-55 (4-B) ABS relay
- A-56 (4-B) Horn relay

NOTE

Connector numbers enclosed by a frame are newly added, changed or relocated.

Petrol <L.H. drive vehicles>

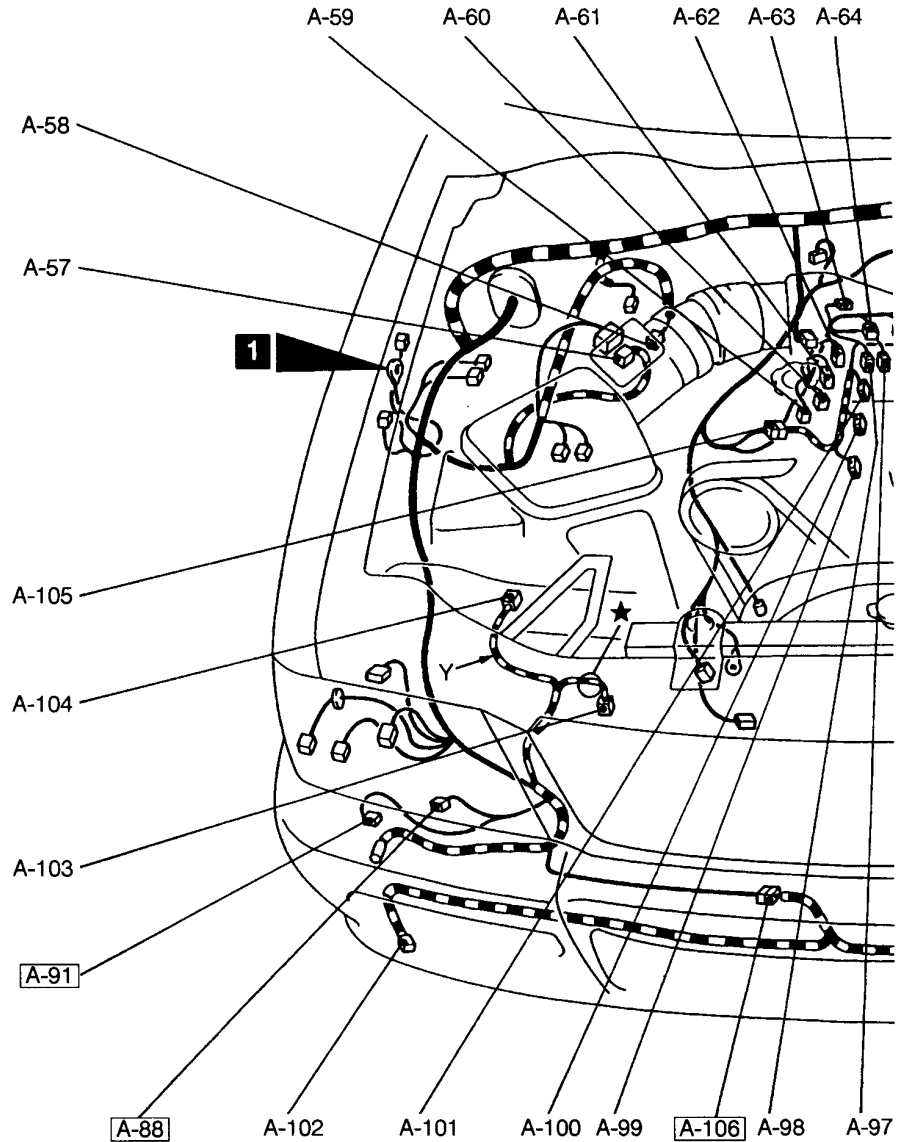
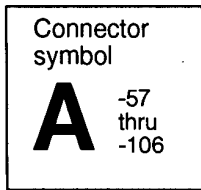

- | | | | |
|-------------|--|-------------|---|
| A-57 (2-GR) | Free-wheeling hub engage switch
<Vehicles with auto-cruise control system> | A-65 (2-B) | Ignition coil (1) |
| A-58 (2-GR) | Free-wheeling hub engage switch
<Vehicles without auto-cruise control system> | A-66 (2-B) | Ignition coil (3) |
| A-59 (2-B) | Engine coolant temperature sensor | A-67 (2-GR) | Injector No.6 |
| A-60 (1-B) | Engine coolant temperature gauge unit | A-68 (2-GR) | Injector No.4 |
| A-61 (6-B) | Power transistor | A-69 (2-GR) | Injector No.2 |
| A-62 (3-B) | Power transistor | A-80 (4-B) | DRL relay 1 |
| A-63 (1-B) | Capacitor | A-81 (4-B) | DRL relay 2 |
| A-64 (2-B) | Ignition coil (2) | A-82 (4) | Tail lamp relay |
| | | A-83 (12-B) | DRL-ECU |
| | | A-84 (6-B) | Headlamp washer relay |
| | | A-85 (10-B) | Front wiring harness and A/C wiring harness combination |

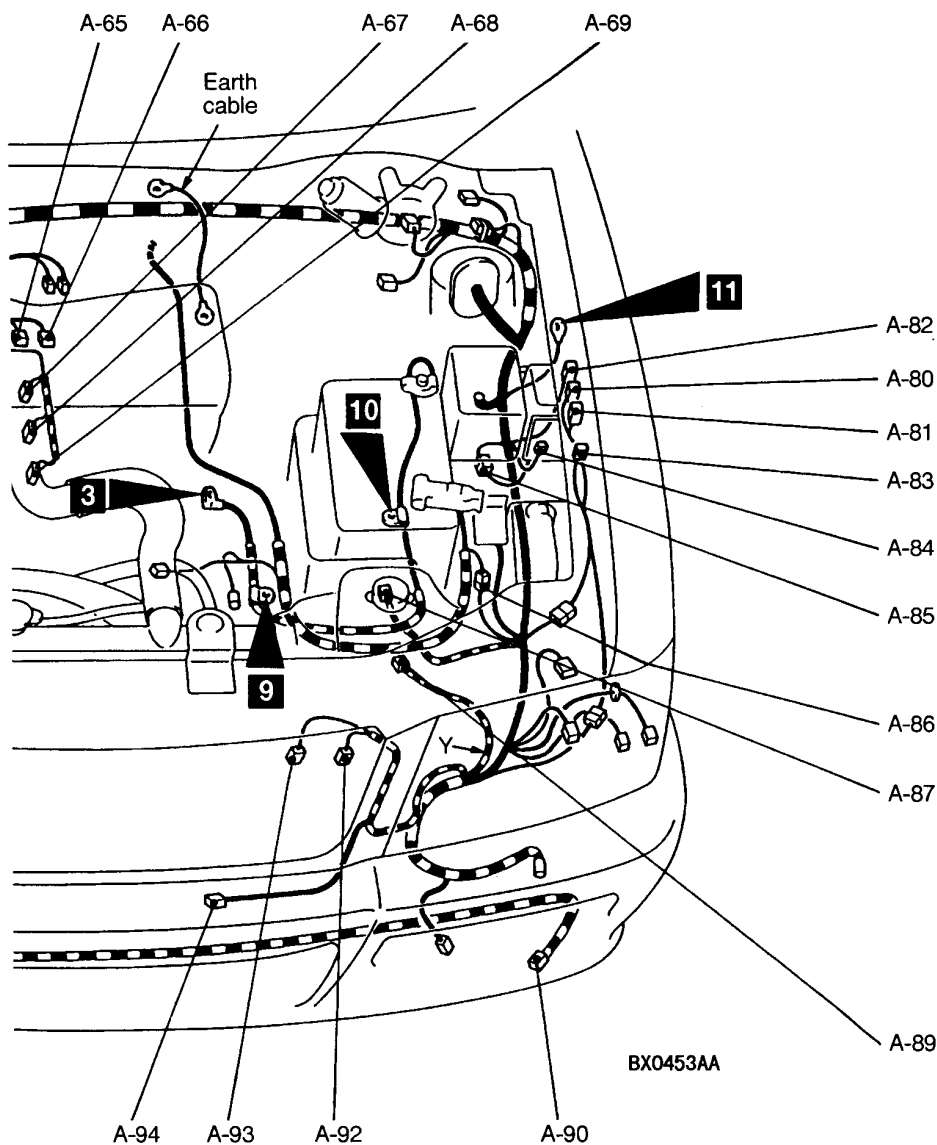

- A-86 (6-B) Battery cable wiring harness and front wiring harness combination
- A-87 (2-B) Wheel speed sensor (front: LH) <ABS>
- A-88 (2-B) Headlamp washer motor
- A-89 (2-R) Front impact sensor (LH)
- A-90 (2-BR) Front fog lamp (LH)
- A-91 (2-B) Windshield washer motor
- A-92 (2-BR) Dual pressure switch <A/C>
- A-93 (2-B) Condenser fan motor <A/C>
- A-94 (2-BR) Outside air thermo sensor <A/C>
- A-97 (3-B) Crank angle sensor
- A-98 (3-GR) Camshaft position sensor
- A-99 (2-GR) Injector No.1

- A-100 (2-GR) Injector No.3
- A-101 (2-GR) Injector No.5
- A-102 (2-BR) Front fog lamp (RH)
- A-103 (2-B) Wheel speed sensor (front: RH) <ABS>
- A-104 (2-R) Front impact sensor (RH)
- A-105 (8-B) Injection wiring harness and front wiring harness combination
- A-106 (2-BR) Front wiring harness and fog lamp wiring harness combination

NOTE
Connector numbers enclosed by a frame are newly added or relocated.

ENGINE COMPARTMENT

Petrol <R.H. drive vehicles>

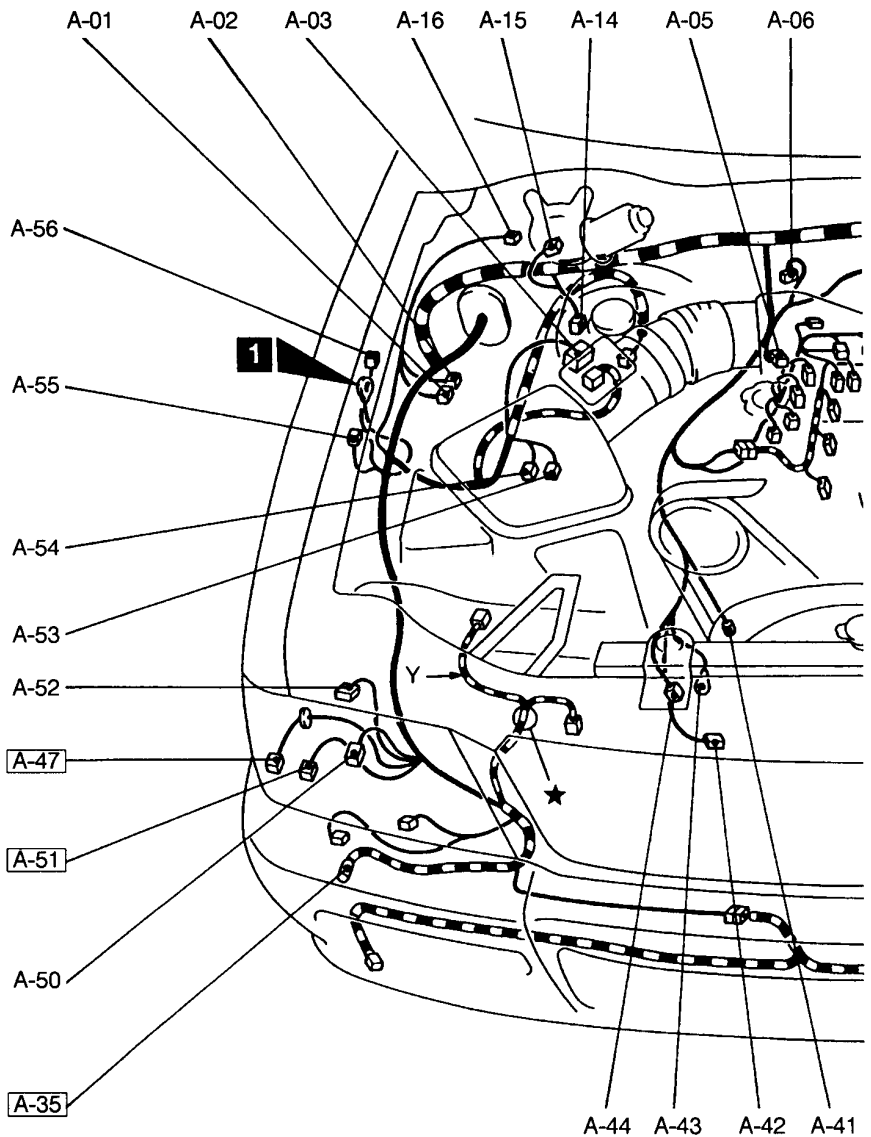
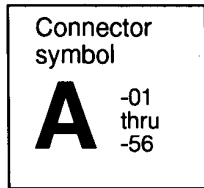

- A-01 (26-B) ABS-ECU
- A-02 (4-GR) ABS-ECU
- A-03 (7-B) Air flow sensor
- A-04 (4-B) Auto-cruise vacuum pump
- A-05 (6-B) Idle speed control servo
- A-06 (4-B) Throttle position sensor
- A-07 (2-B) Purge control solenoid valve
- A-08 (2-BR) EGR solenoid valve
- A-14 (2-B) Brake fluid level switch
- A-15 (4-B) Windshield wiper motor
- A-16 (2-B) Wiper deicer
- A-17 (1-L) Engine speed detection connector

- A-20X (4)
- A-21X (5)
- A-23X (5)
- A-24X (5)
- A-25X (5)
- A-26X (4)
- A-27X (4)
- A-31 (3)
- A-33 (2)
- A-34 (3-B)
- A-35 (1-B)

- Alternator relay
- Starter relay <A/T>
- Headlamp relay
- Blower relay
- Storage connector
- A/C compressor relay <A/C>
- Condenser fan relay <A/C>
- Headlamp leveling unit (LH)
- Position lamp (LH)
- Headlamp (LH)
- Horn (LO)

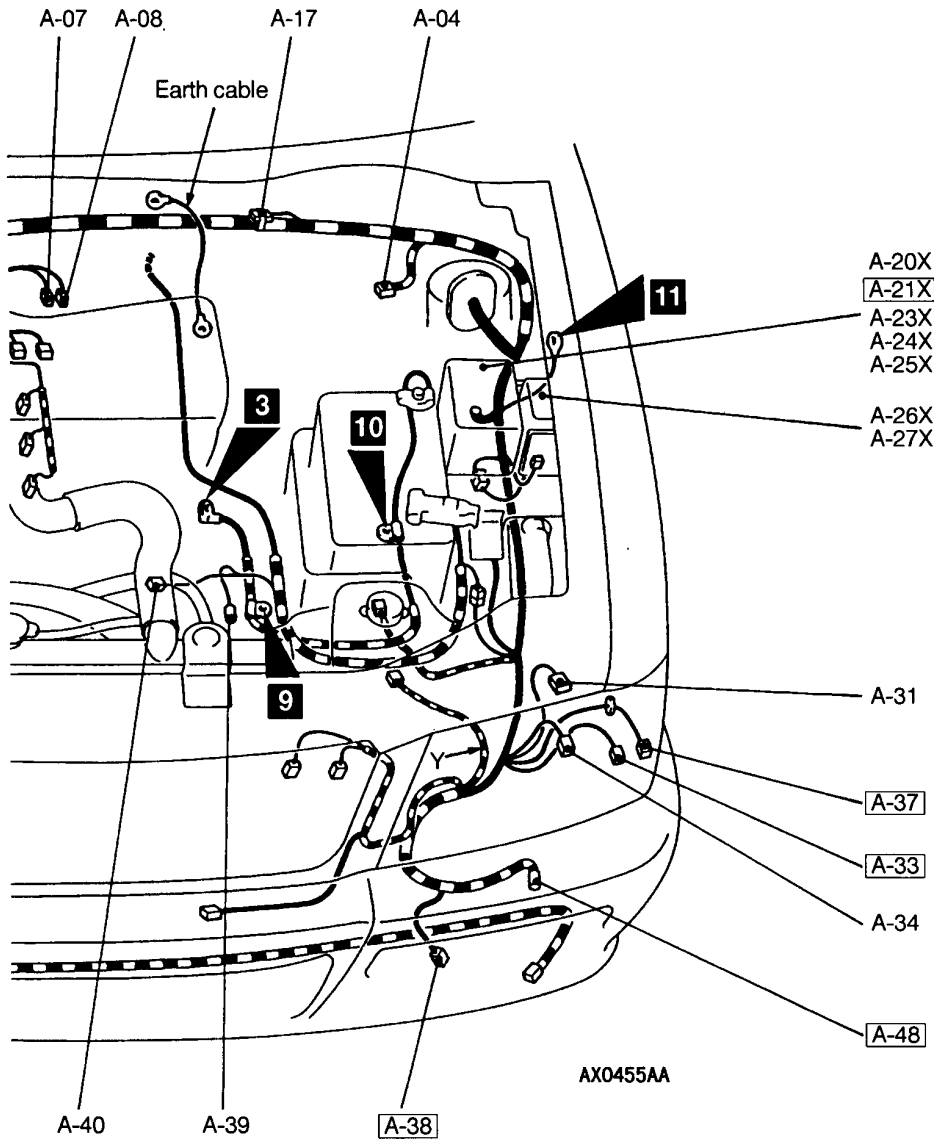

- A-37 (2-B) Front turn-signal lamp (LH)
- A-38 (2-BR) Outside thermo sensor <Multi-meter>
- A-39 (3-B) Magnetic clutch and refrigerant temperature switch
- A-40 (1-B) Oil pressure gauge unit
- A-41 (1) Power steering oil pressure switch
- A-42 (2-B) Engine oil level sensor
- A-43 (1) Alternator
- A-44 (2-B) Alternator
- A-47 (2-B) Front turn-signal lamp (RH)
- A-48 (1-B) Horn (HI)

- A-50 (3-B) Headlamp (RH)
- A-51 (2) Position lamp (RH)
- A-52 (3) Headlamp leveling unit (RH)
- A-53 (2-B) Solenoid valve A <4WD>
- A-54 (2-B) Solenoid valve B <4WD>
- A-55 (4-B) ABS relay
- A-56 (4-B) Horn relay

NOTE
Connector numbers enclosed by a frame are newly added, changed or relocated.

Petrol <R.H. drive vehicles>

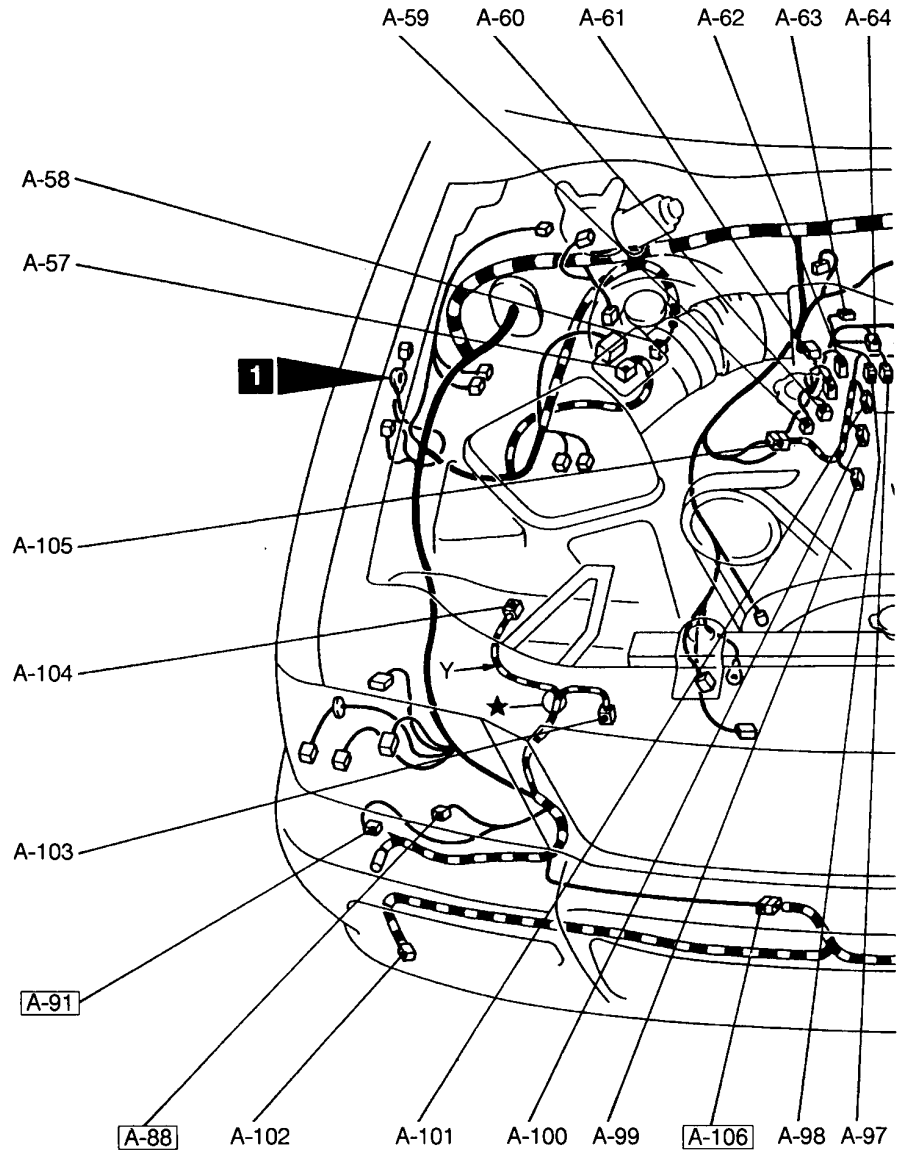
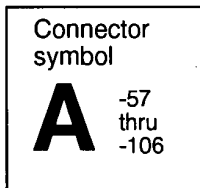

- | | | | |
|-------------|--|-------------|---|
| A-57 (2-GR) | Free-wheeling hub engage switch
<Vehicles with auto-cruise control system> | A-64 (2-B) | Ignition coil (2) |
| A-58 (2-GR) | Free-wheeling hub engage switch
<Vehicles without auto-cruise control system> | A-65 (2-B) | Ignition coil (1) |
| A-59 (2-B) | Engine coolant temperature sensor | A-66 (2-B) | Ignition coil (3) |
| A-60 (1-B) | Engine coolant temperature gauge unit | A-67 (2-GR) | Injector No.6 |
| A-61 (6-B) | Power transistor | A-68 (2-GR) | Injector No.4 |
| A-62 (3-B) | Power transistor | A-69 (2-GR) | Injector No.2 |
| A-63 (1-B) | Capacitor | A-84 (6-B) | Headlamp washer relay |
| | | A-85 (10-B) | Front wiring harness and A/C wiring harness combination |
| | | A-86 (6-B) | Battery cable wiring harness and front wiring harness combination |

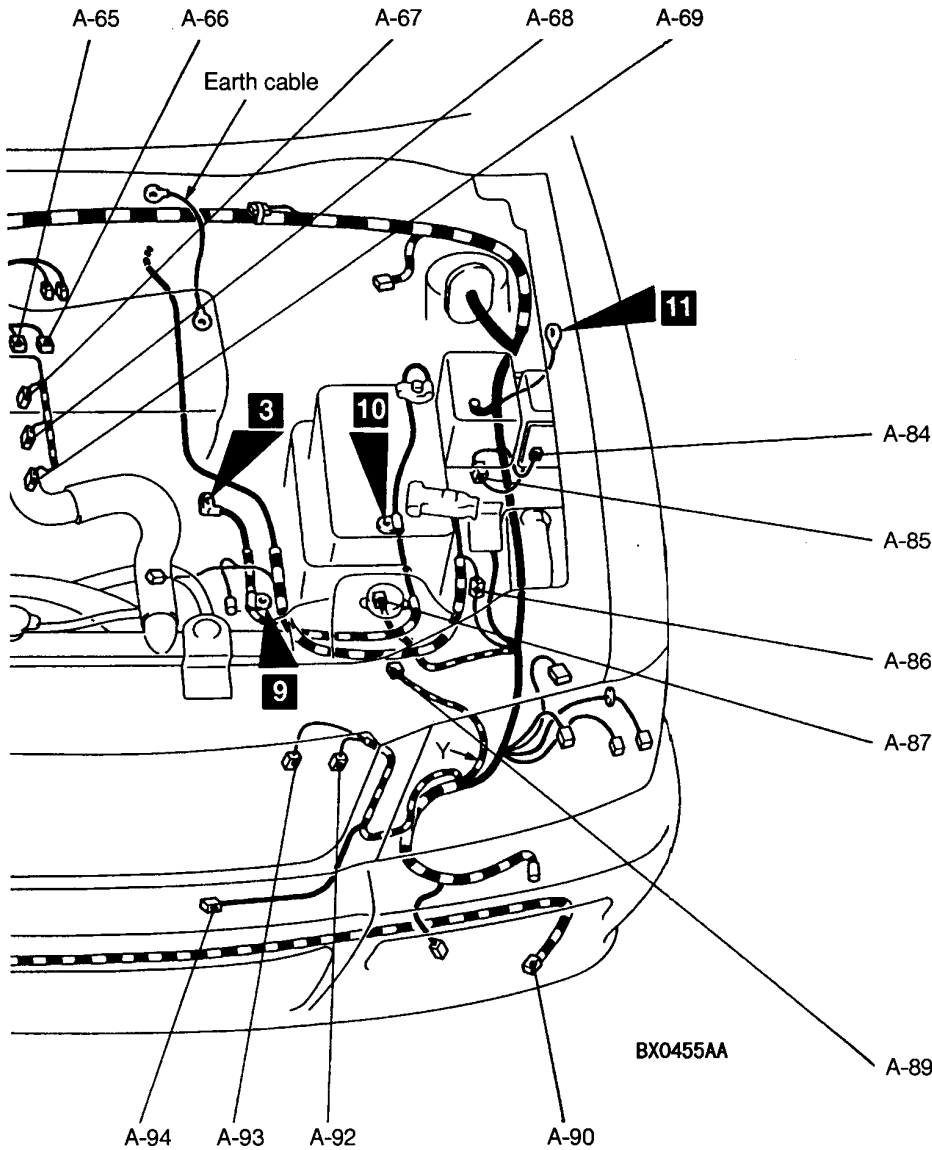

- A-87 (2-B) Wheel speed sensor (front: LH) <ABS>
- A-88 (2-B) Headlamp washer motor
- A-89 (2-R) Front impact sensor (LH)
- A-90 (2-BR) Front fog lamp (LH)
- A-91 (2-B) Windshield washer motor
- A-92 (2-BR) Dual pressure switch <A/C>
- A-93 (2-B) Condenser fan motor <A/C>
- A-94 (2-BR) Outside air thermo sensor <A/C>
- A-97 (3-B) Crank angle sensor
- A-98 (3-GR) Camshaft position sensor
- A-99 (2-GR) Injector No.1
- A-100 (2-GR) Injector No.3

- A-101 (2-GR) Injector No.5
- A-102 (2-BR) Front fog lamp (RH)
- A-103 (2-B) Wheel speed sensor (front: RH) <ABS>
- A-104 (2-R) Front impact sensor (RH)
- A-105 (8-B) Injection wiring harness and front wiring harness combination
- A-106 (2-BR) Front wiring harness and fog lamp wiring harness combination

NOTE

Connector numbers enclosed by a frame are newly added or relocated.

ENGINE COMPARTMENT

Diesel <L.H. drive vehicles>

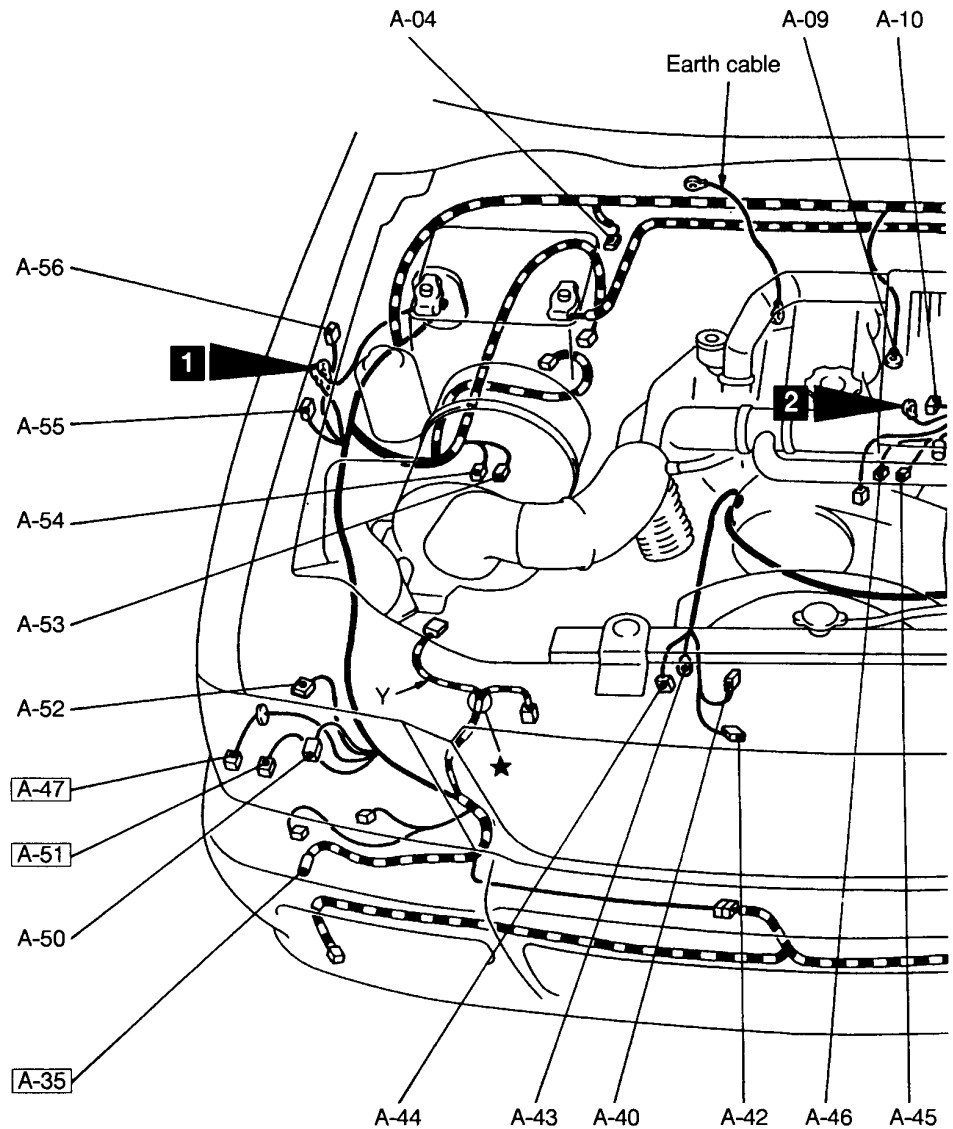
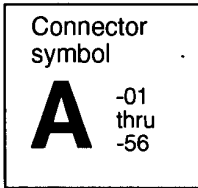

- | | | | |
|-------------|---|-------------|---|
| A-01 (26-B) | ABS-ECU | A-20X (4) | Alternator relay |
| A-02 (4-GR) | ABS-ECU | A-21X (5) | Starter relay |
| A-04 (4-B) | Auto-cruise vacuum pump | A-22X (5) | Intercooler fan relay |
| A-09 (1) | Glow plug | A-23X (5) | Headlamp relay |
| A-10 (3-B) | Fuel cut valve-controller | A-24X (5) | Blower relay |
| A-11 (4-B) | Lever (Throttle) position sensor and timer solenoid | A-25X (5) | Storage connector |
| A-12 (1) | Starter | A-26X (4) | A/C compressor relay <A/C> |
| A-13 (1-B) | Starter | A-27X (4) | Condenser fan relay <A/C> |
| A-14 (2-B) | Brake fluid level switch | A-28X (4) | Condenser fan control relay <A/C> |
| A-15 (4-B) | Windshield wiper motor | A-29 (6-B) | Fuel injection pump wiring harness and front wiring harness combination |
| A-16 (2-B) | Wiper deicer | A-30 (10-B) | DRL wiring harness and front wiring harness combination |
| A-18 (2-B) | EGR solenoid valve (2) | A-31 (3) | Headlamp leveling unit (LH) |
| A-19 (2-B) | EGR solenoid valve (1) | | |

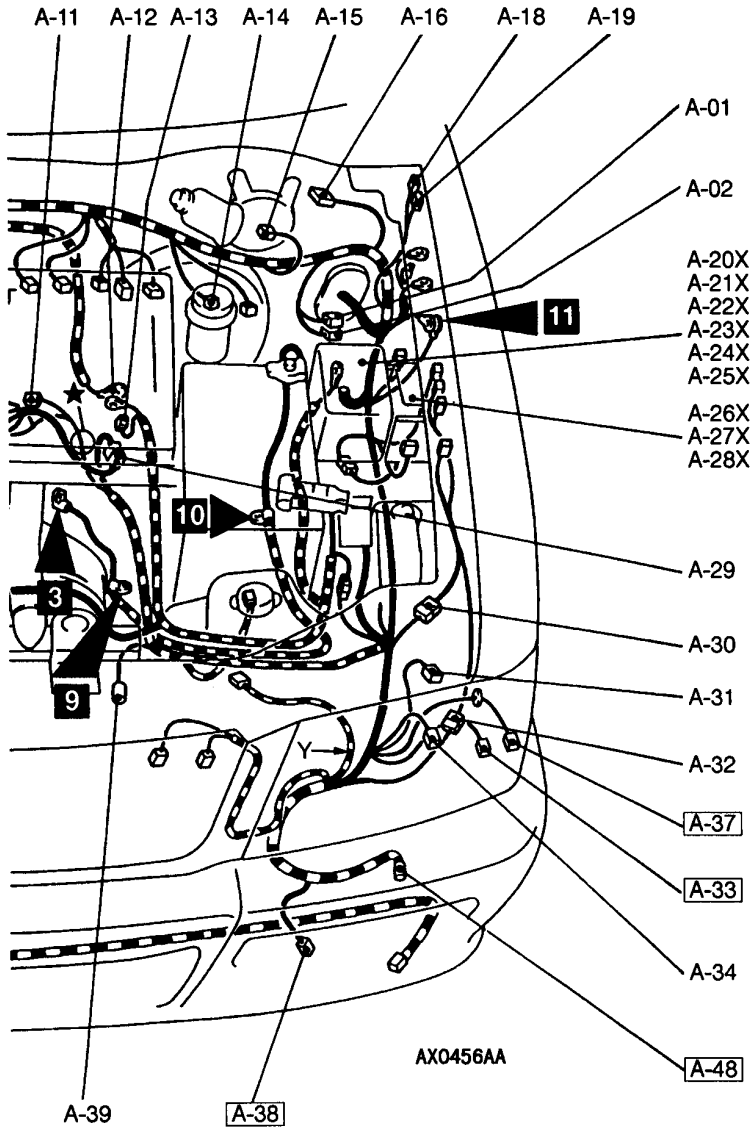

<Vehicles without DRL>

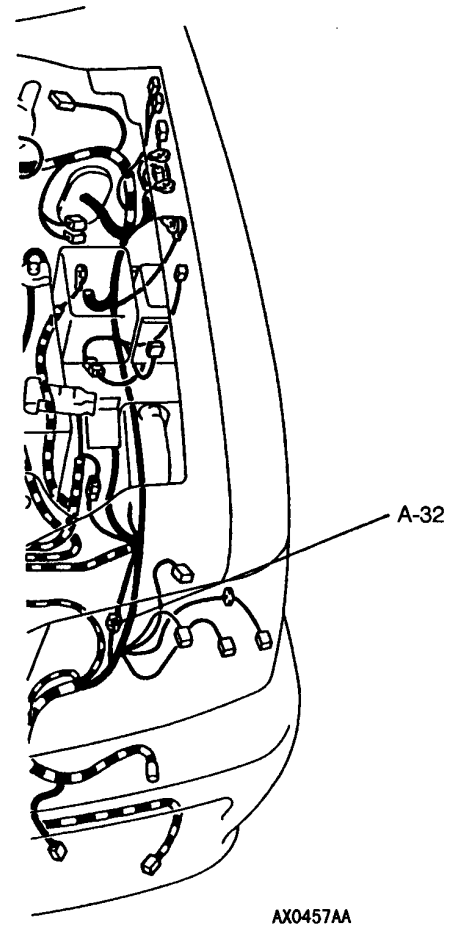

- | | | | |
|---|--|--|---|
| A-32 (10-B) | DRL wiring harness and front wiring harness combination | A-46 (1) | Engine coolant temperature switch (for condenser fan control) |
| A-33 (2) | Position lamp (LH) | A-47 (2-B) | Front turn-signal lamp (RH) |
| A-34 (3-B) | Headlamp (LH) | A-48 (1-B) | Horn (HI) |
| A-35 (1-B) | Horn (LO) | A-50 (3-B) | Headlamp (RH) |
| A-37 (2-B) | Front turn-signal lamp (LH) | A-51 (2) | Position lamp (RH) |
| A-38 (2-BR) | Outside thermo sensor <Multi-meter> | A-52 (3) | Headlamp leveling unit (RH) |
| A-39 (3-B) | Magnetic clutch and refrigerant temperature switch | A-53 (2-B) | Solenoid valve A <4WD> |
| A-40 (1-B) | Oil pressure gauge unit | A-54 (2-B) | Solenoid valve B <4WD> |
| A-42 (2-B) | Engine oil level sensor | A-55 (4-B) | ABS relay |
| A-43 (1) | Alternator | A-56 (4-B) | Horn relay |
| A-44 (2-B) | Alternator | | |
| A-45 (2) | Engine coolant temperature switch (for A/C compressor control) | | |
- NOTE**
Connector numbers enclosed by a frame are newly added, changed or relocated.

Diesel <L.H. drive vehicles>

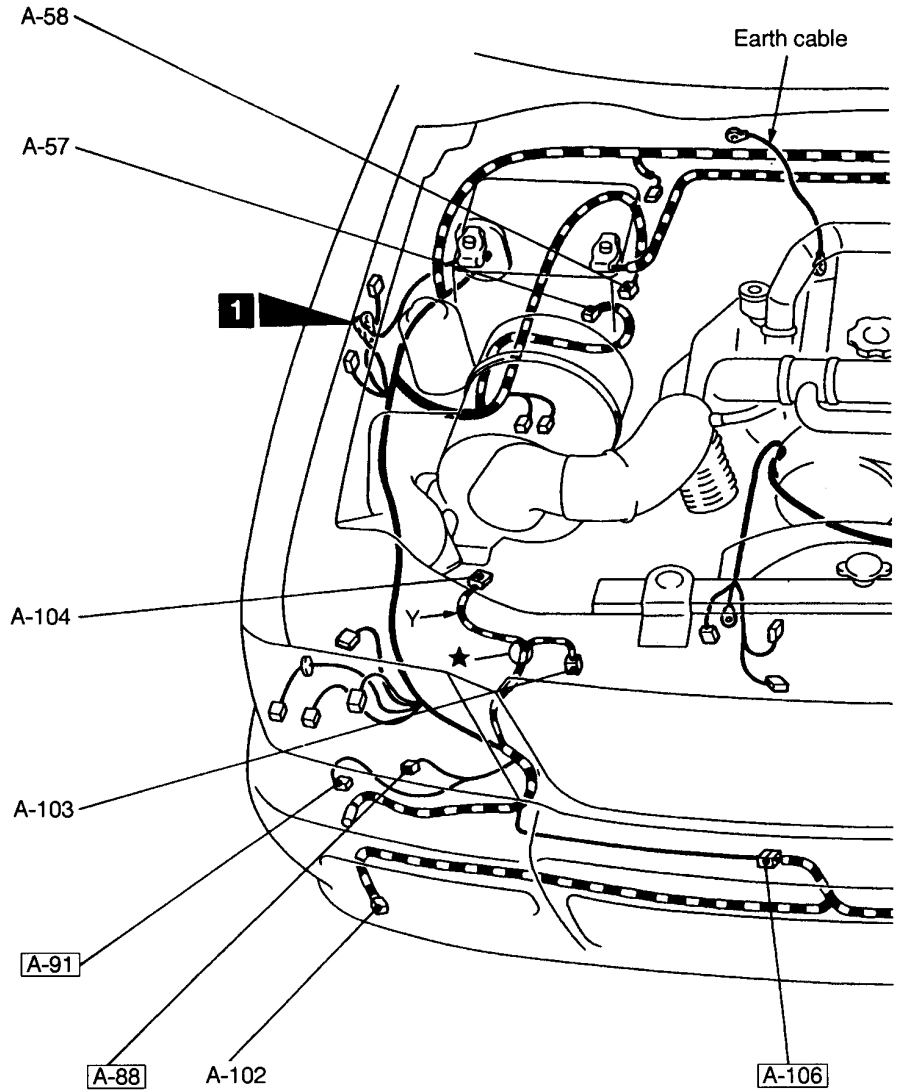
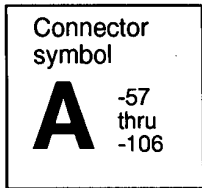

- | | | | |
|-------------|--|-------------|------------------------------|
| A-57 (2-GR) | Free-wheeling hub engage switch
<Vehicles with auto-cruise control system> | A-74 (2) | Idle-up solenoid valve <A/C> |
| A-58 (2-GR) | Free-wheeling hub engage switch
<Vehicles without auto-cruise control system> | A-75 (2-B) | Vacuum switch |
| A-70 (2-BR) | Intake air temperature switch | A-76 (4-B) | Fuel line heater relay |
| A-71 (2-B) | Intercooler fan motor | A-77 (1) | Glow plug relay |
| A-72 (2-GR) | Fuel line heater | A-78 (1-B) | Glow plug relay |
| A-73 (2-B) | Water level switch | A-79 (1) | Glow plug relay |
| | | A-80 (4-B) | DRL relay 1 |
| | | A-81 (4-B) | DRL relay 2 |
| | | A-82 (4) | Tail lamp relay |
| | | A-83 (12-B) | DRL-ECU |

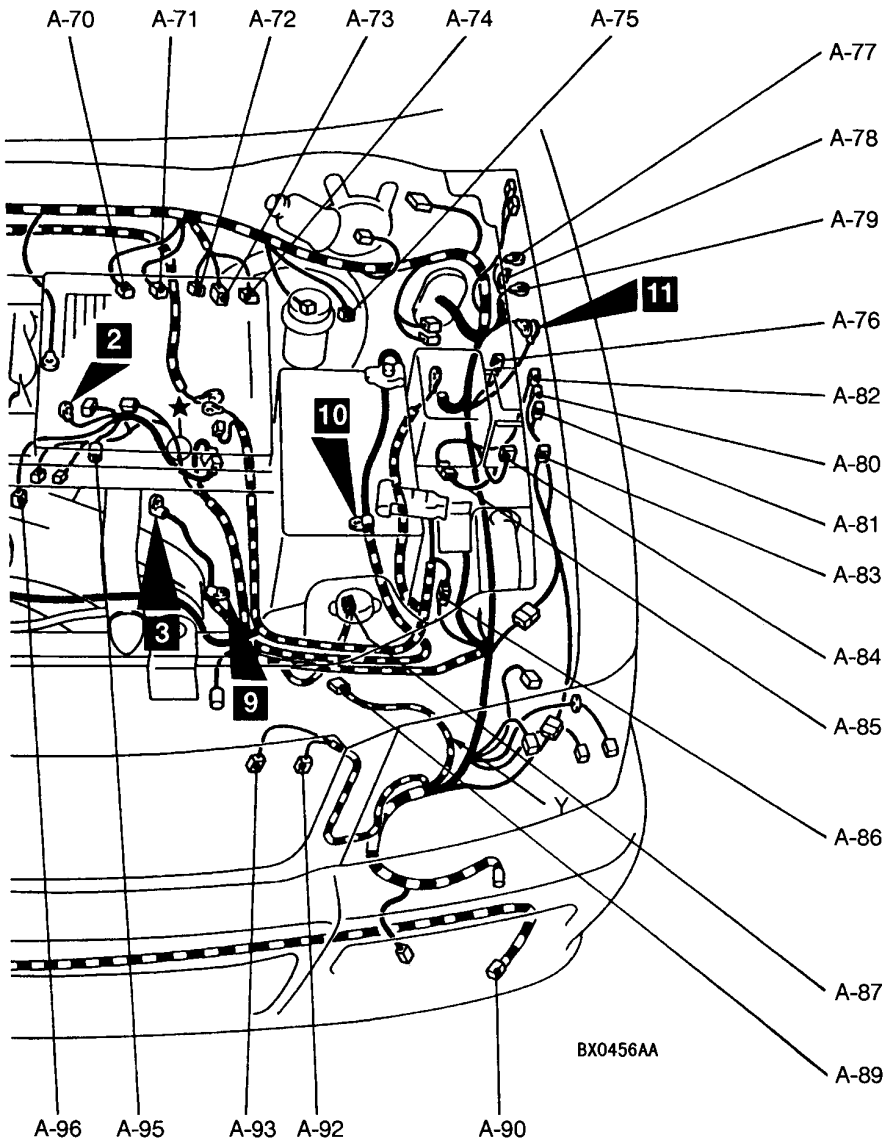

- A-84 (6-B) Headlamp washer relay
- A-85 (10-B) Front wiring harness and A/C wiring harness combination
- A-86 (6) Battery cable wiring harness and front wiring harness combination
- A-87 (2-B) Wheel speed sensor (front: LH) <ABS>
- A-88 (2-B) Headlamp washer motor
- A-89 (2-R) Front impact sensor (LH)
- A-90 (2-BR) Front fog lamp (LH)
- A-91 (2-B) Windshield washer motor
- A-92 (2-BR) Dual pressure switch <A/C>
- A-93 (2-B) Condenser fan motor <A/C>
- A-94 (2-BR) Outside air thermo sensor <A/C>

- A-95 (2) Revolution pick-up sensor
- A-96 (2) Engine coolant temperature sensor and gauge unit
- A-102 (2-BR) Front fog lamp (RH)
- A-103 (2-B) Wheel speed sensor (front: RH) <ABS>
- A-104 (2-R) Front impact sensor (RH)
- A-106 (2-BR) Front wiring harness and fog lamp wiring harness combination

NOTE
Connector numbers enclosed by a frame are newly added or relocated.

ENGINE COMPARTMENT

Diesel <R.H. drive vehicles>

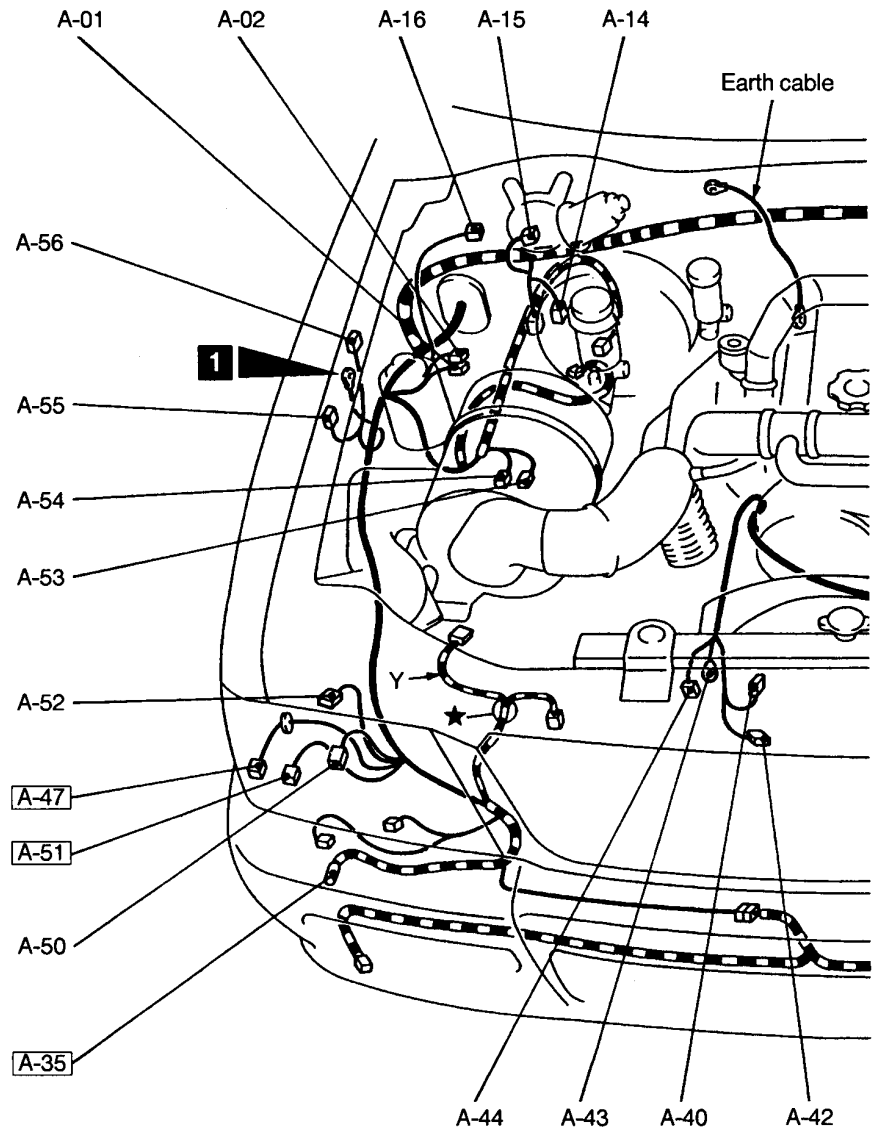
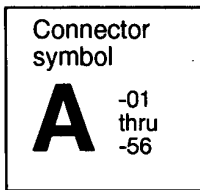

A-01 (26-B)	ABS-ECU	A-20X (4)	Alternator relay
A-02 (4-GR)	ABS-ECU	A-21X (5)	Starter relay
A-04 (4-B)	Auto-cruise vacuum pump	A-22X (5)	Intercooler fan relay
A-09 (1)	Glow plug	A-23X (5)	Headlamp relay
A-10 (3-B)	Fuel cut valve-controller	A-24X (5)	Blower relay
A-11 (4-B)	Lever (Throttle) position sensor and timer solenoid	A-25X (5)	Storage connector
A-12 (1)	Starter	A-26X (4)	A/C compressor relay <A/C>
A-13 (1-B)	Starter	A-27X (4)	Condenser fan relay <A/C>
A-14 (2-B)	Brake fluid level switch	A-28X (4)	Condenser fan control relay <A/C>
A-15 (4-B)	Windshield wiper motor	A-29 (6-B)	Fuel injection pump wiring harness and front wiring harness combination
A-16 (2-B)	Wiper deicer	A-31 (3)	Headlamp leveling unit (LH)
A-18 (2-B)	EGR solenoid valve (2)	<u>A-33</u> (2)	Position lamp (LH)
A-19 (2-B)	EGR solenoid valve (1)	A-34 (3-B)	Headlamp (LH)

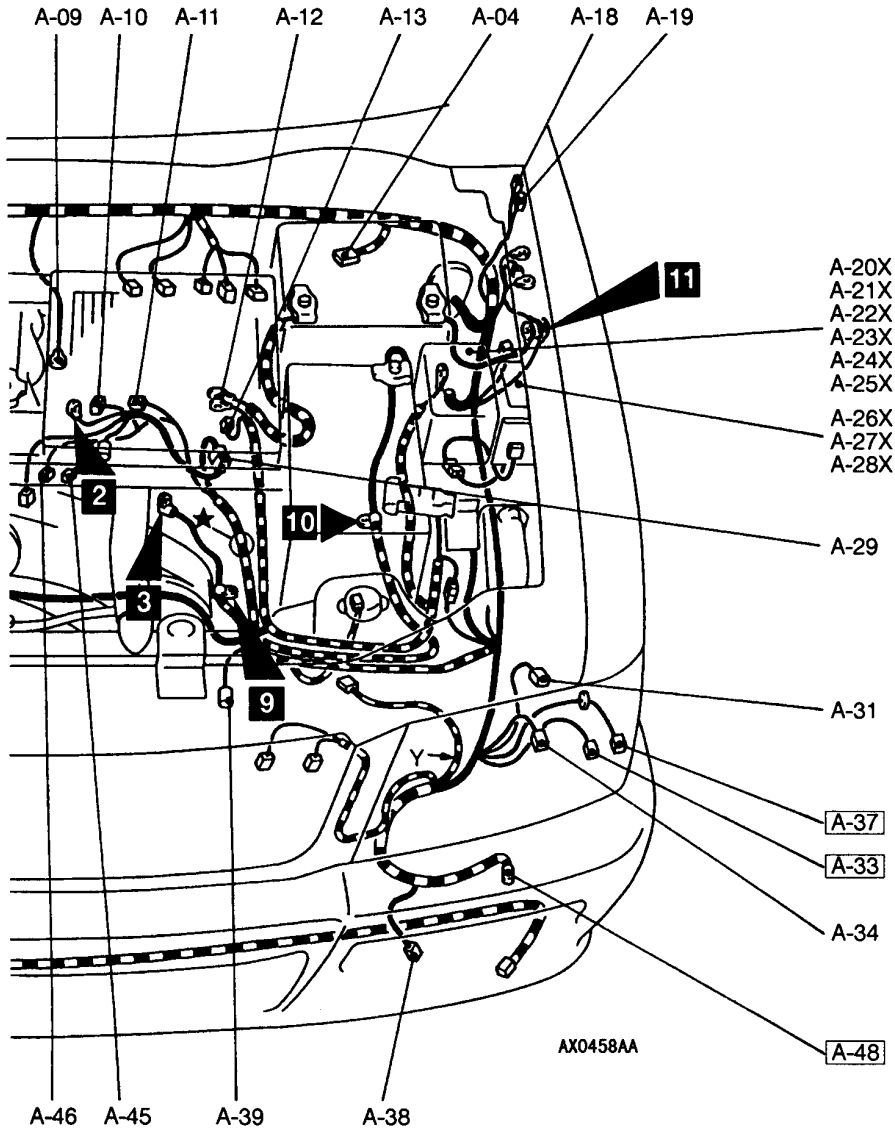

- A-35 (1-B) Horn (LO)
- A-37 (2-B) Front turn-signal lamp (LH)
- A-38 (2-BR) Outside thermo sensor <Multi-meter>
- A-39 (3-B) Magnetic clutch and refrigerant temperature switch
- A-40 (1-B) Oil pressure gauge unit
- A-42 (2-B) Engine oil level sensor
- A-43 (1) Alternator
- A-44 (2-B) Alternator
- A-45 (2) Engine coolant temperature switch (for A/C compressor control)
- A-46 (1) Engine coolant temperature switch (for condenser fan control)

- A-47 (2-B) Front turn-signal lamp (RH)
- A-48 (1) Horn (HI)
- A-50 (3-B) Headlamp (RH)
- A-51 (2) Position lamp (RH)
- A-52 (3) Headlamp leveling unit (RH)
- A-53 (2-B) Solenoid valve A <4WD>
- A-54 (2-B) Solenoid valve B <4WD>
- A-55 (4-B) ABS relay
- A-56 (4-B) Horn relay

NOTE

Connector numbers enclosed by a frame are newly added, changed or relocated.

Diesel <R.H. drive vehicles>

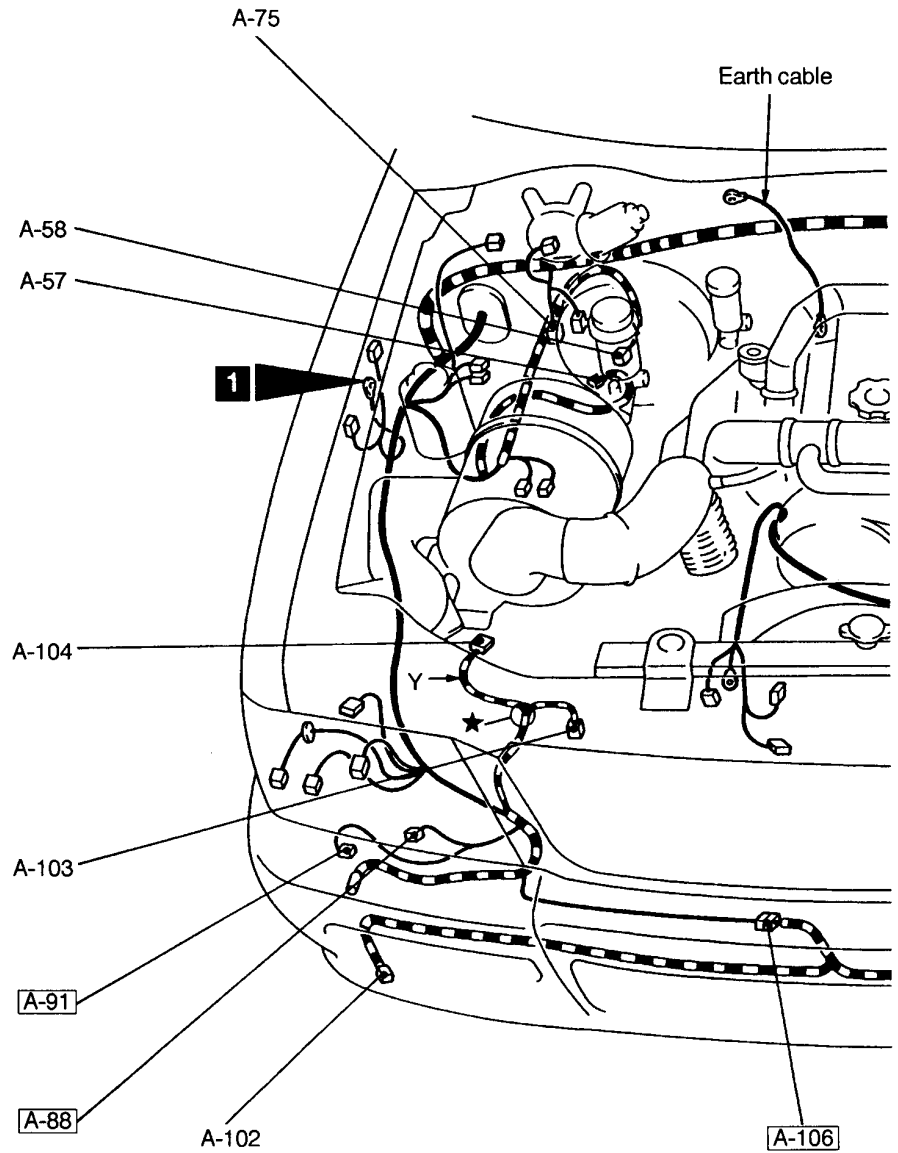
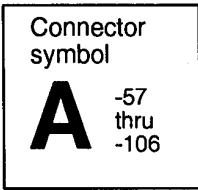

- | | | | |
|-------------|---|-------------|---|
| A-57 (2-GR) | Free-wheeling hub engage switch <Vehicles with auto-cruise control system> | A-74 (2) | Idle-up solenoid valve <A/C> |
| A-58 (2-GR) | Free-wheeling hub engage switch <Vehicles without auto-cruise control system> | A-75 (2-B) | Vacuum switch |
| A-70 (2-BR) | Intake air temperature switch | A-76 (4-B) | Fuel line heater relay |
| A-71 (2-B) | Intercooler fan motor | A-77 (1) | Glow plug relay |
| A-72 (2-GR) | Fuel line heater | A-78 (1-B) | Glow plug relay |
| A-73 (2-B) | Water level switch | A-79 (1) | Glow plug relay |
| | | A-84 (6-B) | Headlamp washer relay |
| | | A-85 (10-B) | Front wiring harness and A/C wiring harness combination |

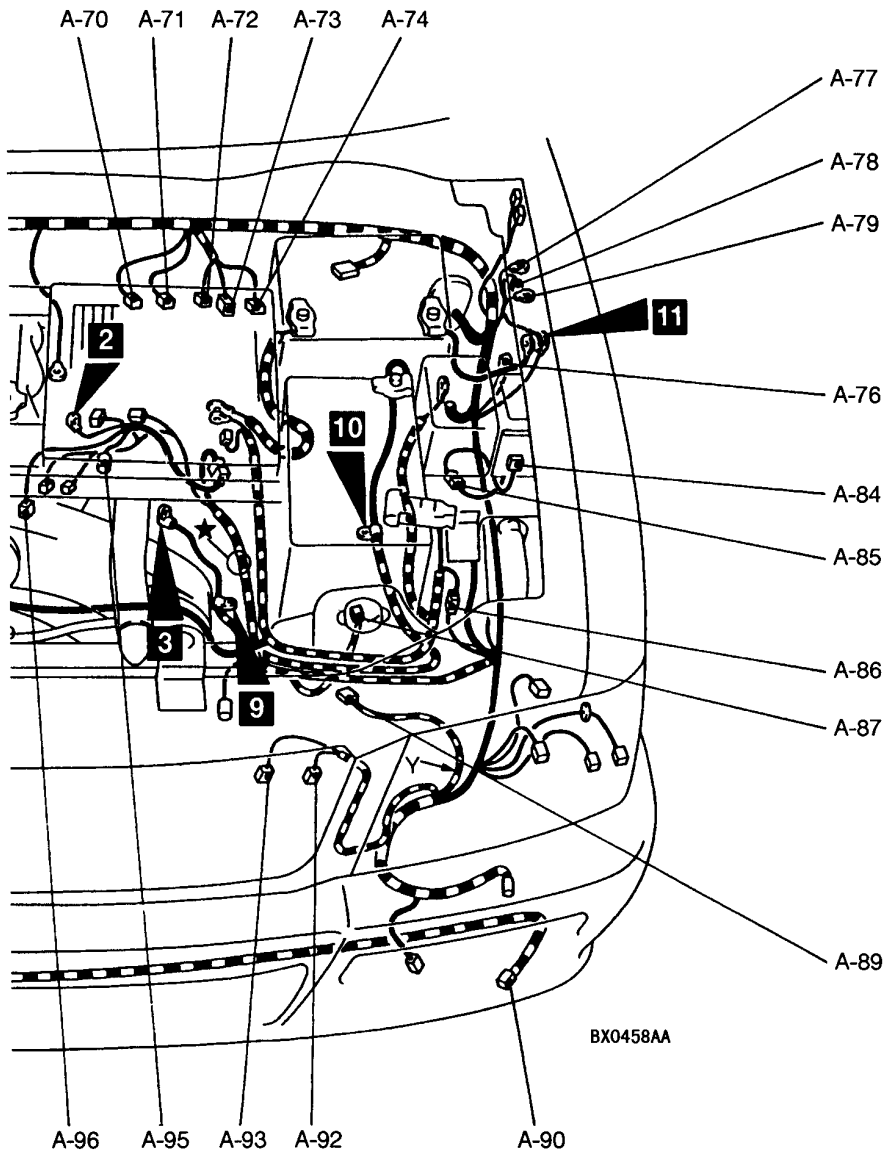

BX0458AA

- | | | | |
|--|---|--|--|
| A-86 (6) | Battery cable wiring harness and front wiring harness combination | A-96 (2) | Engine coolant temperature sensor and gauge unit |
| A-87 (2-B) | Wheel speed sensor (fornt: LH) <ABS> | A-102 (2-BR) | Front fog lamp (RH) |
| A-88 (2-B) | Headlamp washer motor | A-103 (2-B) | Wheel speed sensor (front: RH) <ABS> |
| A-89 (2-R) | Front impact sensor (LH) | A-104 (2-R) | Front impact sensor (RH) |
| A-90 (2-BR) | Front fog lamp (LH) | A-106 (2-BR) | Front wiring harness and fog lamp wiring harness combination |
| A-91 (2-B) | Windshield washer motor | | |
| A-92 (2-BR) | Dual pressure switch <A/C> | | |
| A-93 (2-B) | Condenser fan motor <A/C> | | |
| A-95 (2) | Revolution pick-up sensor | | |

NOTE
Connector numbers enclosed by a frame are newly added or relocated.

TRANSMISSION

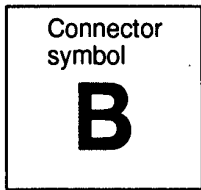

<M/T>

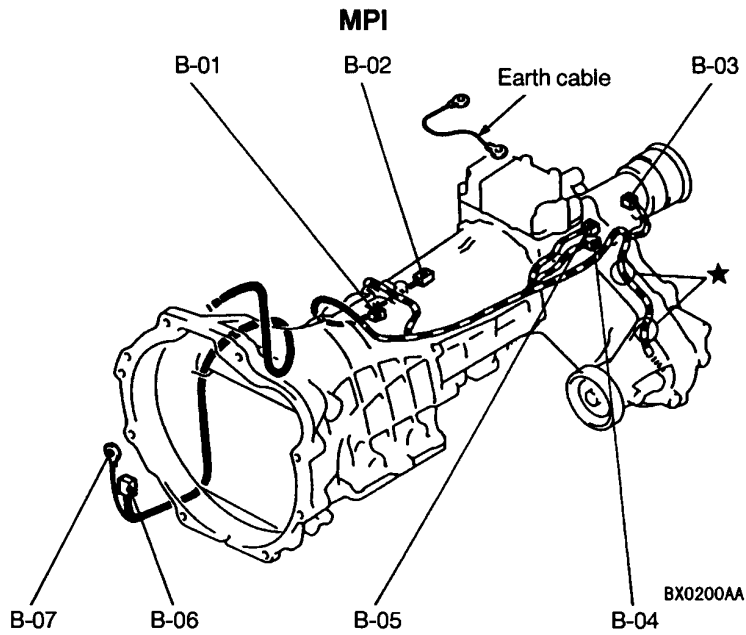

<A/T>

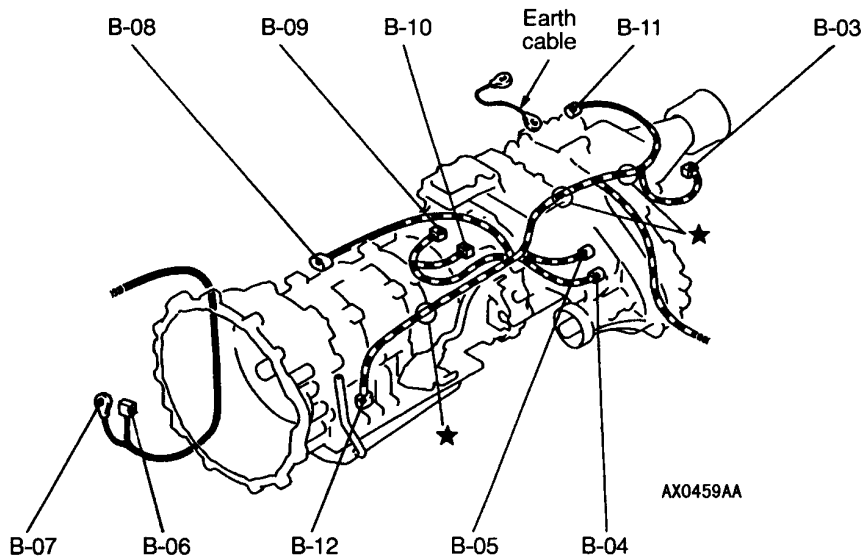

- | | | | |
|-------------|---------------------------------------|-------------|---------------------------------|
| B-01 (2-B) | Back-up lamp switch <M/T> | B-05 (2-B) | 4WD detection switch |
| B-02 (4-B) | Oxygen sensor <M/T> | B-06 (1-B) | Starter |
| B-03 (3-B) | Vehicles speed sensor | B-07 (1) | Starter |
| B-04 (2-GR) | High range/Low range detection switch | B-08 (3-GR) | Output shaft speed sensor <A/T> |

Diesel

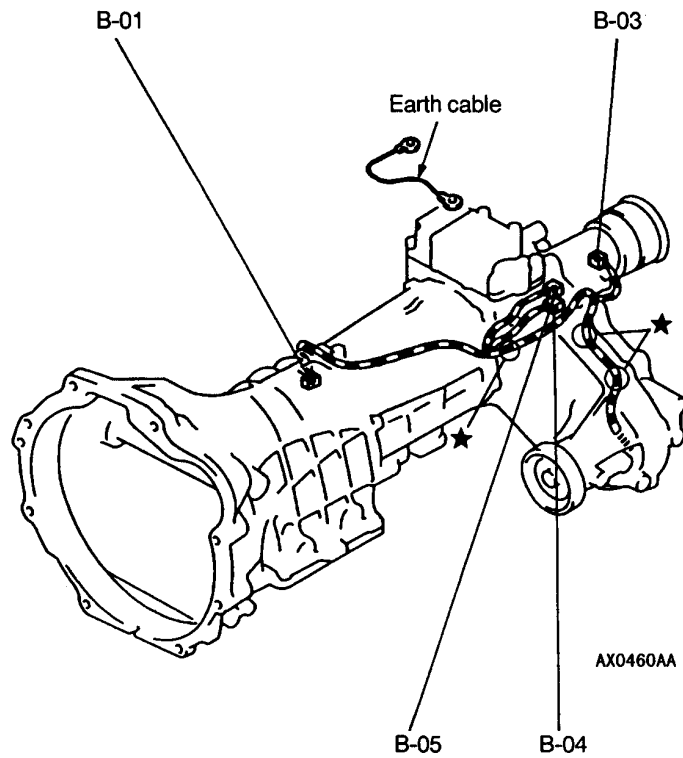

B-09 (10-B) A/T control solenoid valve assembly
B-10 (10-B) Inhibitor switch <A/T>

B-11 (1) Transfer low detection switch
B-12 (3-B) Input shaft speed sensor <A/T>

DASH PANEL

L.H. drive vehicles

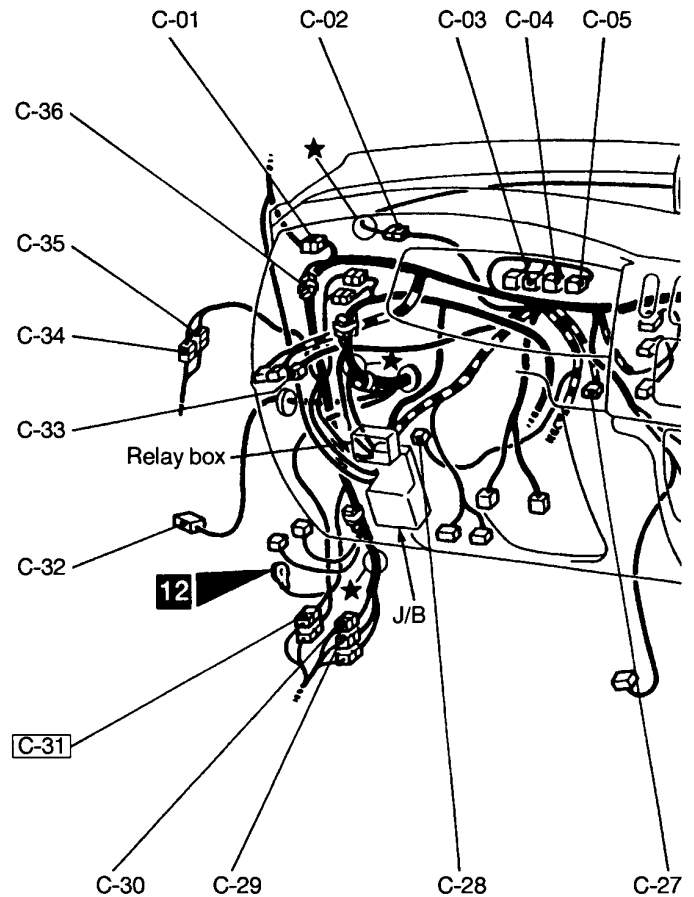
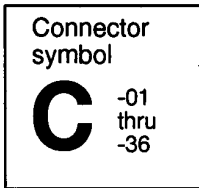

C-01 (20)	Body wiring harness and roof wiring harness combination	C-11 (19)	J/C (1)
C-02 (11)	Body wiring harness and instrument panel wiring harness combination	C-12 (19)	J/C (2)
C-03 (12-B)	Combination meter	C-13 (19)	Body wiring harness and front door wiring harness (passenger's side) combination
C-04 (12)	Combination meter	C-14 (6)	Body wiring harness and front door wiring harness (passenger's side) combination
C-05 (12)	Combination meter	C-15 (12)	Body wiring harness and front wiring harness combination
C-06 (6)	A/C switch	C-16 (1)	Body wiring harness and front wiring harness combination
C-07 (8)	Blower switch	C-17 (22)	Body wiring harness and front wiring harness combination
C-08 (2)	Heater control panel illumination lamp		
C-09 (20-B)	Automatic compressor-controller <Petrol>		
C-10 (3)	Automatic compressor-controller <Diesel>		

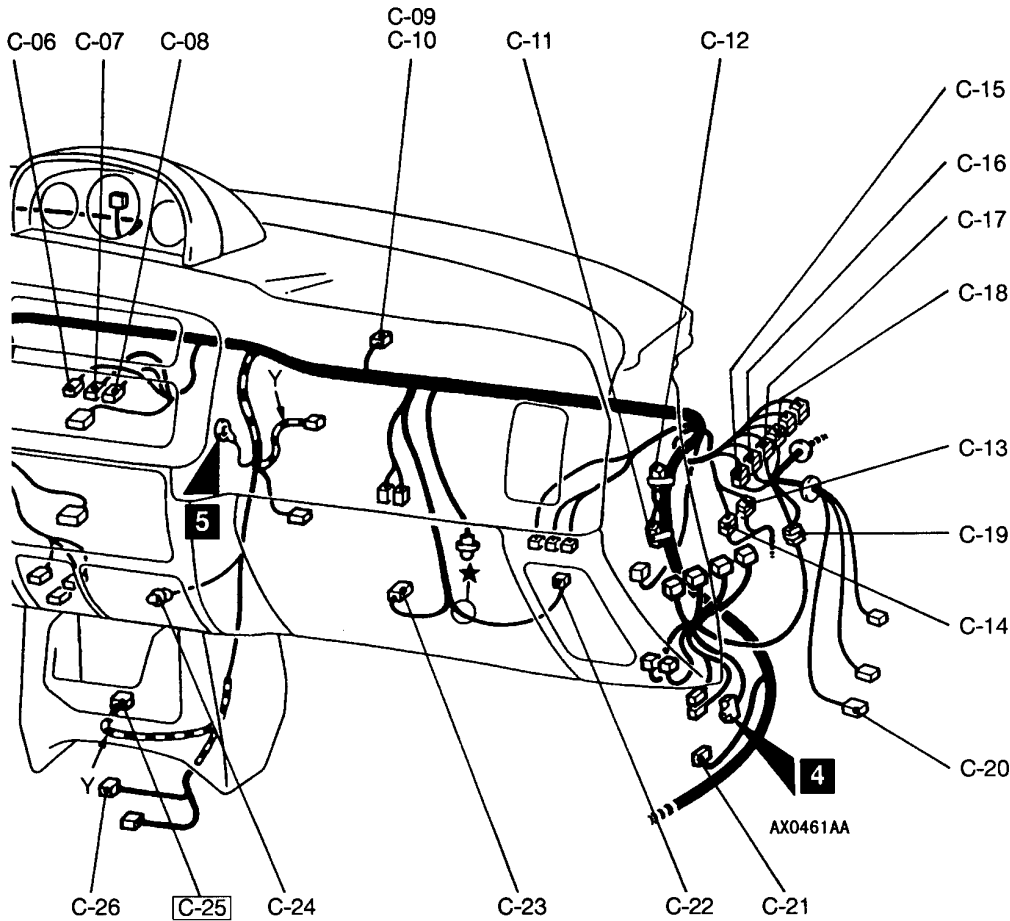

- C-18 (17) Body wiring harness and front wiring harness combination
- C-19 (33) J/C (5)
- C-20 (2-GR) Side turn signal lamp (RH)
- C-21 (10) 4WD indicator-ECU
- C-22 (2) Blower motor
- C-23 (4) Blower resistor
- C-24 (2) Ashtray illumination lamp
- C-25 (20-Y) SRS-ECU
- C-26 (3-B) G sensor <ABS>
- C-27 (4) Headlamp leveling switch
- C-28 (12) Immobilizer-ECU
- C-29 (2) Body wiring harness and transmission wiring harness combination

- C-30 (9) Body wiring harness and transmission wiring harness combination
- C-31 (7) Front wiring harness and transmission wiring harness combination
- C-32 (2-GR) Side turn signal lamp (LH)
- C-33 (4) Rheostat
- C-34 (19) Body wiring harness and front door wiring harness (driver's side) combination
- C-35 (10) Body wiring harness and front door wiring harness (driver's side) combination
- C-36 (3-B) Diode (for rear fog lamp circuit)

NOTE

Connector numbers enclosed by a frame are changed.

L.H. drive vehicles

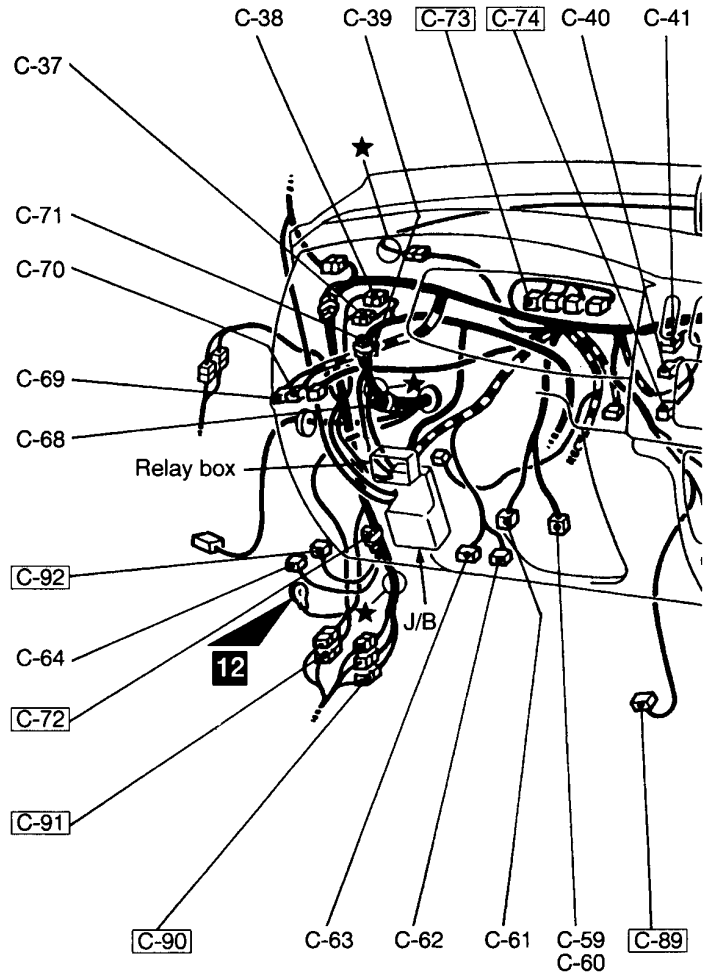
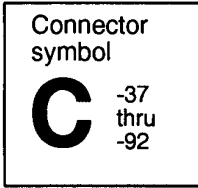

C-37 (22)	Body wiring harness and front wiring harness combination	C-52 (4)	Intercooler fan-ECU <Diesel>
C-38 (6)	Body wiring harness and front wiring harness combination	C-53 (4)	Fuel pump relay <Petrol>
C-39 (2-B)	Diode (for headlamp circuit)	C-54 (4)	Engine control relay <Petrol>
C-40 (6)	Defogger switch	C-55 (14)	Radio and tape player
C-41 (10)	Hazard warning switch	C-56 (1-B)	Cigarette lighter
C-42 (4)	Rear heater indicator	C-57 (2)	Cigarette lighter illumination lamp
C-43 (14)	Multi-meter	C-58 (1)	Cigarette lighter
C-44 (4)	Rear fog lamp relay	C-59 (2-B)	Stop lamp switch <Vehicles without auto-cruise control system>
C-45 (2-R)	Air bag module (squib) (passenger's side)	C-60 (4-B)	Stop lamp switch <Vehicles with auto-cruise control system>
C-46 (2)	Air thermo sensor <A/C>	C-61 (2)	Clutch pedal position switch <Vehicles with auto-cruise control system>
C-47 (26-G)	Engine-ECU <Petrol-M/T>	C-62 (12)	Diagnosis connector (2)
C-48 (26-Y)	Glow-ECU <Diesel>	C-63 (16-B)	Diagnosis connector (1)
C-49 (16-G)	Engine-ECU <Petrol-M/T>	C-64 (16-B)	Auto-cruise control-ECU
C-50 (12-G)	Engine-ECU <Petrol-M/T>	C-65 (4-L)	Defogger relay
C-51 (22-G)	Engine-ECU <Petrol-M/T>	C-66 (4)	Engine oil level relay <Petrol>

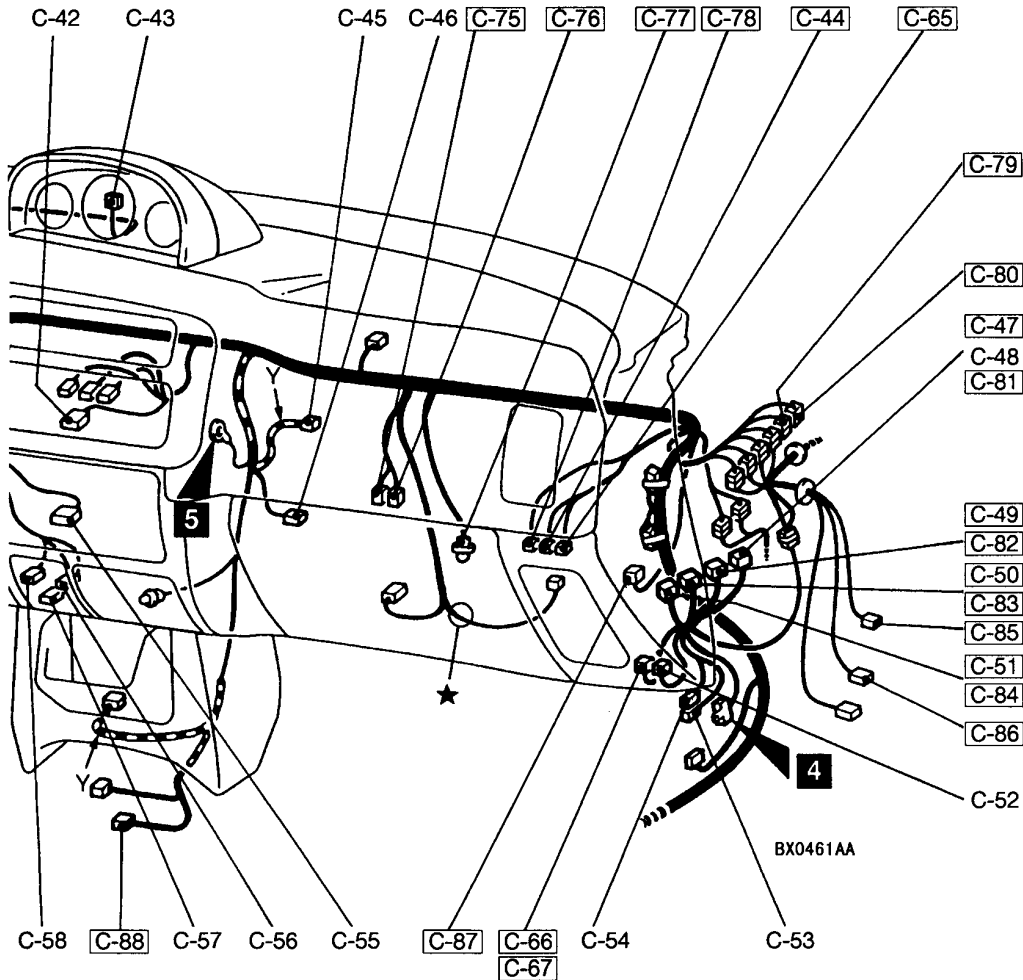

- | | | | |
|---------------------|--|---------------------|--|
| C-67 (4) | Engine oil level relay <Diesel> | C-83 (28-GR) | Engine-A/T-ECU <Petrol-A/T> |
| C-68 (19) | J/C (3) | C-84 (30-GR) | Engine-A/T-ECU <Petrol-A/T> |
| C-69 (6) | Front fog lamp switch | C-85 (2) | Motor antenna |
| C-70 (6-B) | Rear fog lamp switch | C-86 (3-B) | Antenna length sensor |
| C-71 (19) | J/C (4) | C-87 (4) | A/T control relay |
| C-72 (4-B) | Diode (for sunroof circuit) | C-88 (2) | A/T selector lever position illumination lamp |
| C-73 (10) | Combination meter | C-89 (2-B) | Wide-open throttle switch |
| C-74 (6) | Hold switch <A/T> | C-90 (20-B) | Body wiring harness and transmission wiring harness combination |
| C-75 (1) | Glove box lamp switch | C-91 (22) | Front wiring harness and transmission wiring harness combination |
| C-76 (1) | Glove box lamp switch | C-92 (14) | Motor antenna-ECU |
| C-77 (1) | Glove box lamp | | |
| C-78 (8) | Hazard warning relay | | |
| C-79 (9) | Body wiring harness and front wiring harness combination | | |
| C-80 (8) | Body wiring harness and front wiring harness combination | | |
| C-81 (35-GR) | Engine-A/T-ECU <Petrol-A/T> | | |
| C-82 (26-GR) | Engine-A/T-ECU <Petrol-A/T> | | |

NOTE
Connector numbers enclosed by a frame are newly added, changed or relocated.

DASH PANEL

R.H. drive vehicles

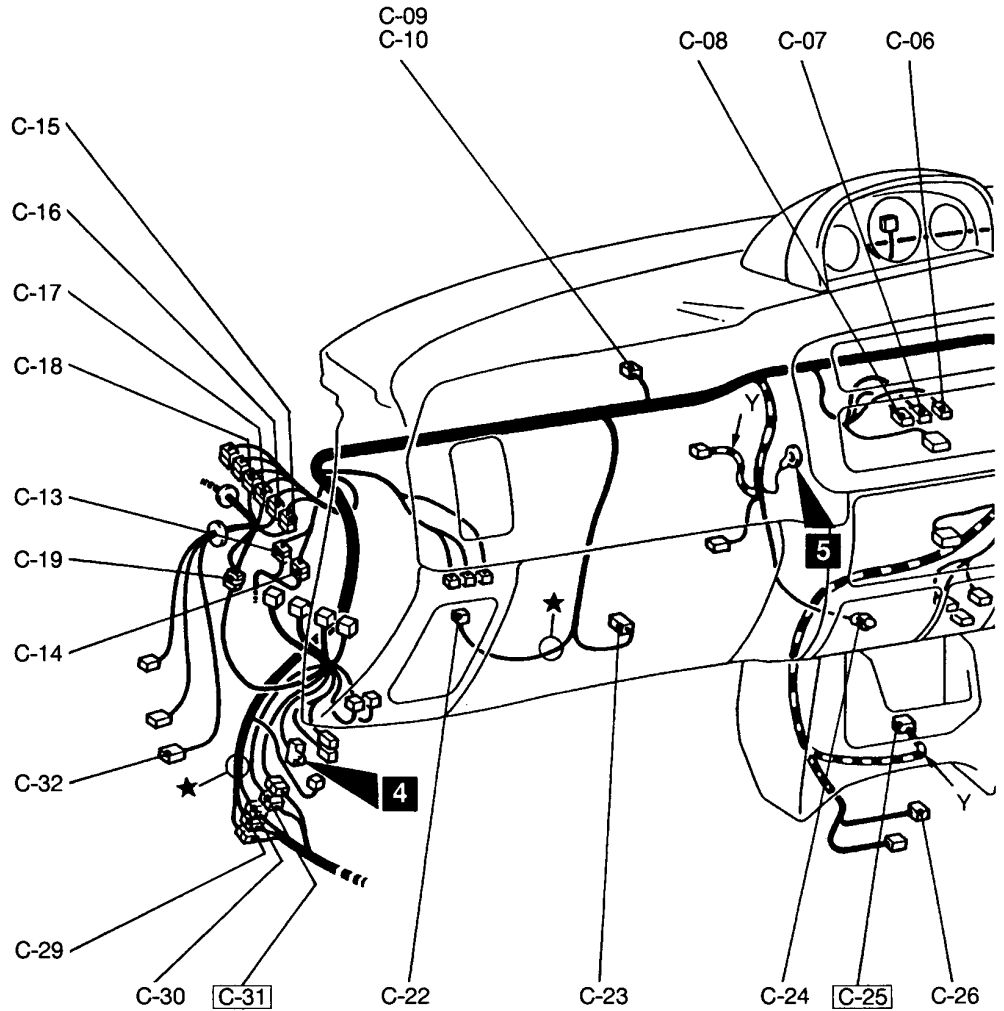
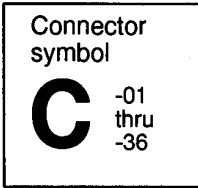

C-01 (20)	Body wiring harness and roof wiring harness combination	C-11 (19)	J/C (1)
C-02 (11)	Body wiring harness and instrument panel wiring harness combination	C-12 (19)	J/C (2)
C-03 (12-B)	Combination meter	C-13 (15)	Body wiring harness and front door wiring harness (passenger's side) combination
C-04 (12)	Combination meter	C-14 (6)	Body wiring harness and front door wiring harness (passenger's side) combination
C-05 (12)	Combination meter	C-15 (12)	Body wiring harness and front wiring harness combination
C-06 (6)	A/C switch	C-16 (1)	Body wiring harness and front wiring harness combination
C-07 (8)	Blower switch	C-17 (22)	Body wiring harness and front wiring harness combination
C-08 (2)	Heater control panel illumination lamp		
C-09 (20-B)	Automatic compressor-controller <Petrol>		
C-10 (3)	Automatic compressor-controller <Diesel>		

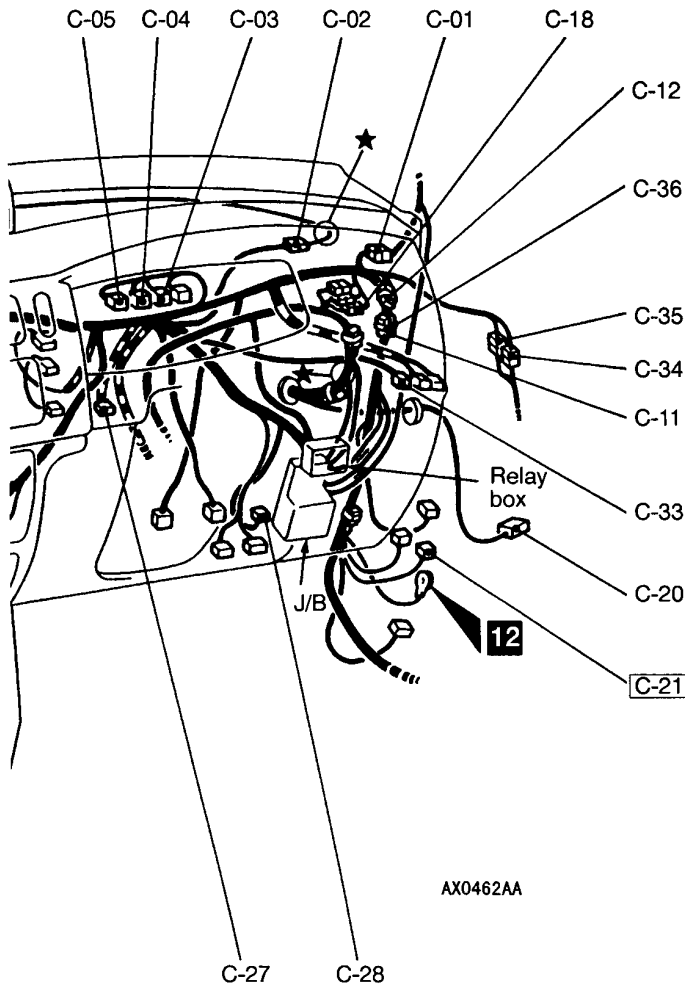

- | | | | |
|--------------------|---|-----------------|---|
| C-18 (17) | Body wiring harness and front wiring harness combination | C-30 (9) | Body wiring harness and transmission wiring harness combination |
| C-19 (33) | J/C (5) | C-31 (7) | Front wiring harness and transmission wiring harness combination |
| C-20 (2-GR) | Side turn signal lamp (RH) | C-32 (2-GR) | Side turn signal lamp (LH) |
| C-21 (10) | 4WD indicator-ECU | C-33 (4) | Rheostat |
| C-22 (2) | Blower motor | C-34 (19) | Body wiring harness and front door wiring harness (driver's side) combination |
| C-23 (4) | Blower resistor | C-35 (10) | Body wiring harness and front door wiring harness (driver's side) combination |
| C-24 (2) | Ashtray illumination lamp | C-36 (3-B) | Diode (for rear fog lamp circuit) |
| C-25 (20-Y) | SRS-ECU | | |
| C-26 (3-B) | G sensor <ABS> | | |
| C-27 (4) | Headlamp leveling switch | | |
| C-28 (12) | Immobilizer-ECU | | |
| C-29 (2) | Body wiring harness and transmission wiring harness combination | | |

NOTE
Connector numbers enclosed by a frame are changed or relocated.

R.H. drive vehicles

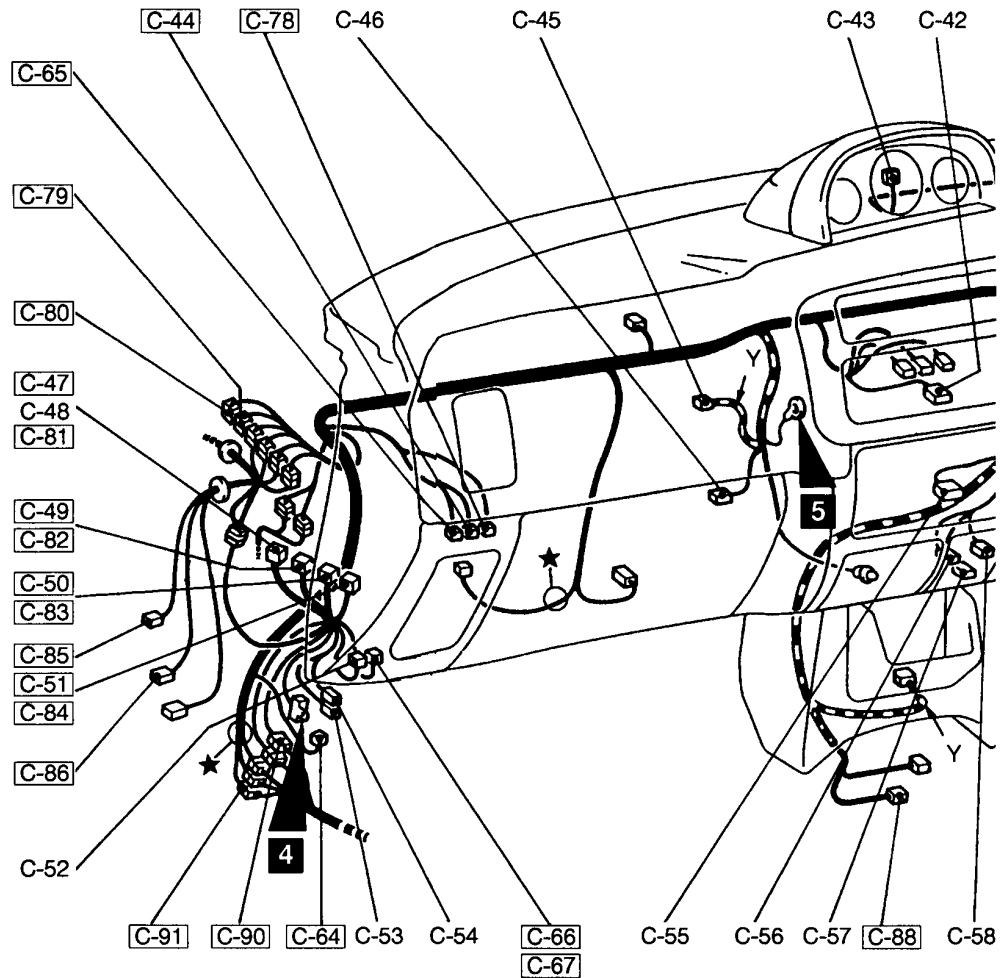
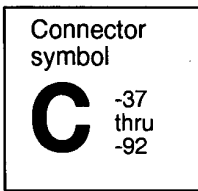

- | | | | |
|-------------|--|-------------|---|
| C-37 (22) | Body wiring harness and front wiring harness combination | C-52 (4) | Intercooler fan-ECU <Diesel> |
| C-38 (6) | Body wiring harness and front wiring harness combination | C-53 (4) | Fuel pump relay <Petrol> |
| C-40 (6) | Defogger switch | C-54 (4) | Engine control relay <Petrol> |
| C-41 (10) | Hazard warning switch | C-55 (14) | Radio and tape player |
| C-42 (4) | Rear heater indicator | C-56 (1-B) | Cigarette lighter |
| C-43 (14) | Multi-meter | C-57 (2) | Cigarette lighter illumination lamp |
| C-44 (4) | Rear fog lamp relay | C-58 (1) | Cigarette lighter |
| C-45 (2-R) | Air bag module (squib) (passenger's side) | C-59 (2-B) | Stop lamp switch <Vehicles without auto-cruise control system> |
| C-46 (2) | Air thermo sensor <A/C> | C-60 (4-B) | Stop lamp switch <Vehicles with auto-cruise control system> |
| C-47 (26-G) | Engine-ECU <Petrol-M/T> | C-61 (2) | Clutch pedal position switch <Vehicles with auto-cruise control system> |
| C-48 (26-Y) | Glow-ECU <Diesel> | C-62 (12) | Diagnosis connector (2) |
| C-49 (16-G) | Engine-ECU <Petrol-M/T> | C-63 (16-B) | Diagnosis connector (1) |
| C-50 (12-G) | Engine-ECU <Petrol-M/T> | C-64 (16-B) | Auto-cruise control-ECU |
| C-51 (22-G) | Engine-ECU <Petrol-M/T> | C-65 (4-L) | Defogger relay |

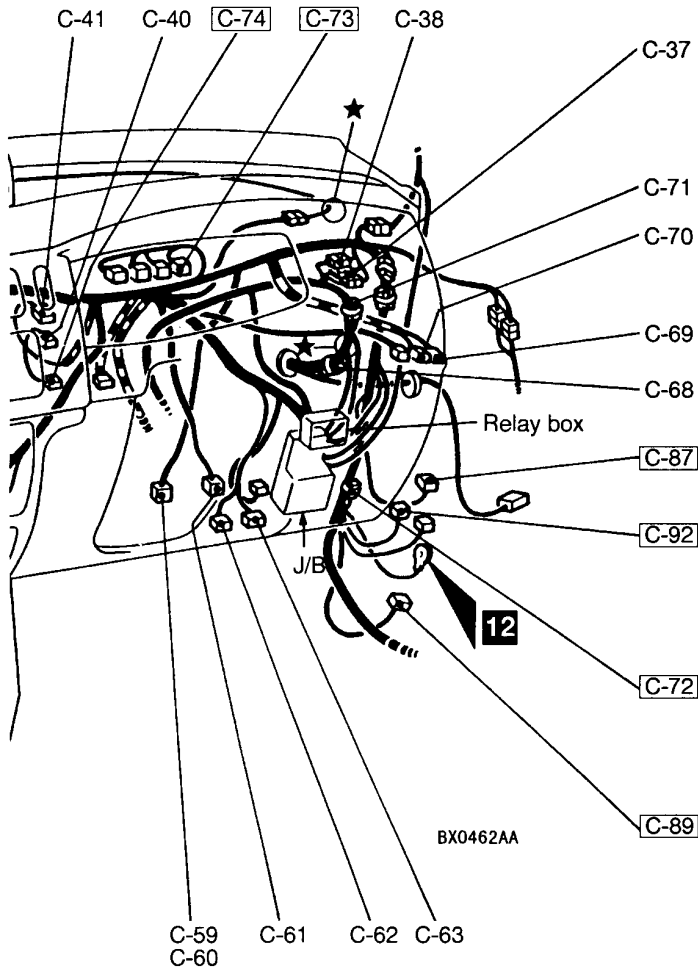

- | | | | |
|---------------------|--|---------------------|--|
| C-66 (4) | Engine oil level relay <Petrol> | C-84 (30-GR) | Engine-A/T-ECU <Petrol-A/T> |
| C-67 (4) | Engine oil level relay <Diesel> | C-85 (2) | Motor antenna |
| C-68 (19) | J/C (3) | C-86 (3-B) | Antenna length sensor |
| C-69 (6) | Front fog lamp switch | C-87 (4) | A/T control relay |
| C-70 (6-B) | Rear fog lamp switch | C-88 (2) | A/T selector lever position illumination lamp |
| C-71 (19) | J/C (4) | C-89 (2-B) | Wide-open throttle switch |
| C-72 (4-B) | Diode (for sunroof circuit) | C-90 (20-B) | Body wiring harness and transmission wiring harness combination |
| C-73 (10) | Combination meter | C-91 (22) | Front wiring harness and transmission wiring harness combination |
| C-74 (6) | Hold switch <A/T> | C-92 (14) | Motor antenna-ECU |
| C-78 (8) | Hazard warning relay | | |
| C-79 (9) | Body wiring harness and front wiring harness combination | | |
| C-80 (8) | Body wiring harness and front wiring harness combination | | |
| C-81 (35-GR) | Engine-A/T-ECU <Petrol-A/T> | | |
| C-82 (26-GR) | Engine-A/T-ECU <Petrol-A/T> | | |
| C-83 (28-GR) | Engine-A/T-ECU <Petrol-A/T> | | |

NOTE

Connector numbers enclosed by a frame are newly added, changed or relocated.

STEERING COLUMN, JUNCTION BLOCK AND RELAY BOX

L.H. drive vehicles

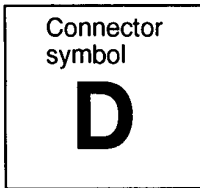

Steering column

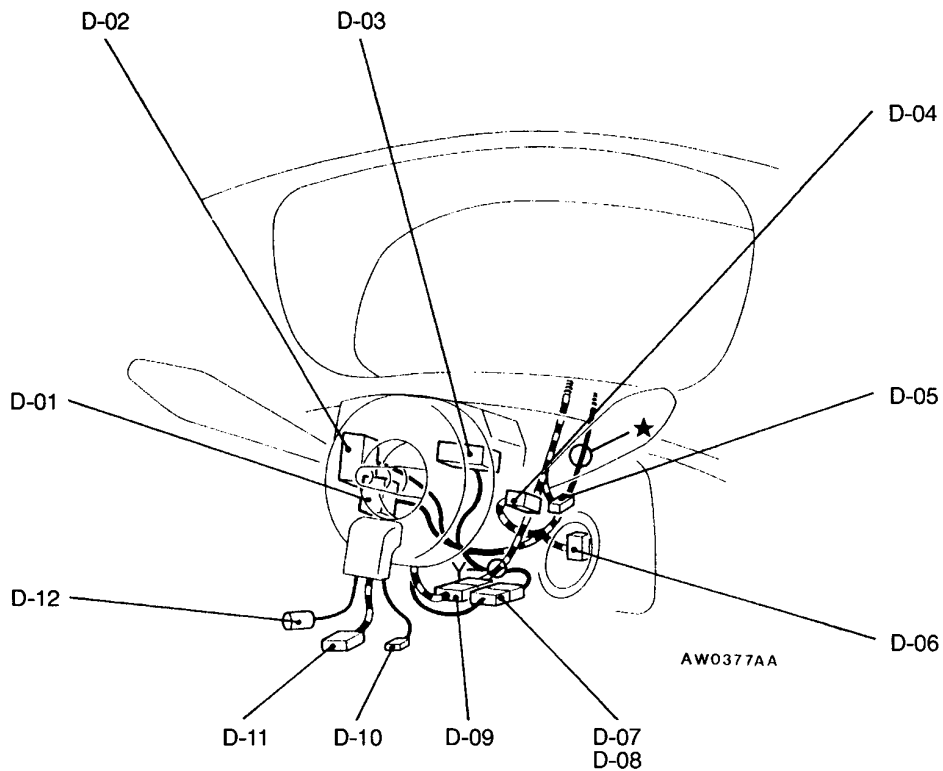

- | | | | |
|------------|--|-------------|--|
| D-01 (6) | Column switch | D-09 (2-R) | Clock spring <SRS> |
| D-02 (12) | Column switch | D-10 (3-Y) | Auto-cruise control switch |
| D-03 (10) | Column switch | D-11 (2) | Air bag module (squib) (driver's side) |
| D-04 (6-B) | Ignition switch | D-12 (1) | Horn switch |
| D-05 (2) | Ignition key ring antenna | D-13X (4) | Accessory socket relay |
| D-06 (7) | Key reminder switch | D-14 (19-B) | Body wiring harness and front wiring harness combination |
| D-07 (3) | Clock spring <Vehicles without auto-cruise control system> | | |
| D-08 (4) | Clock spring <Vehicles with auto-cruise control system> | | |

Relay box in passenger compartment

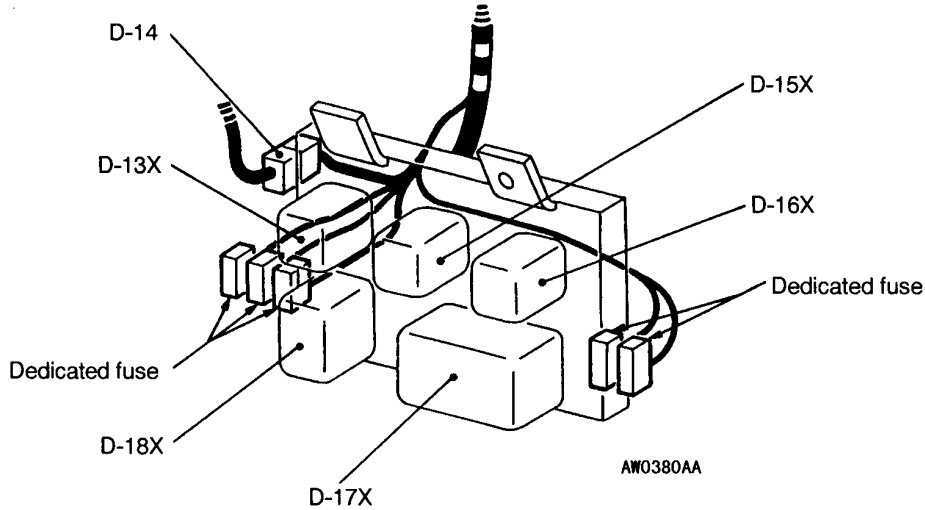

Junction block

<Front side view>

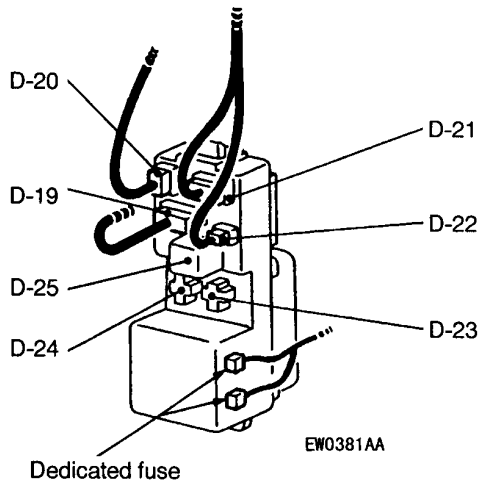

<Rear side view>

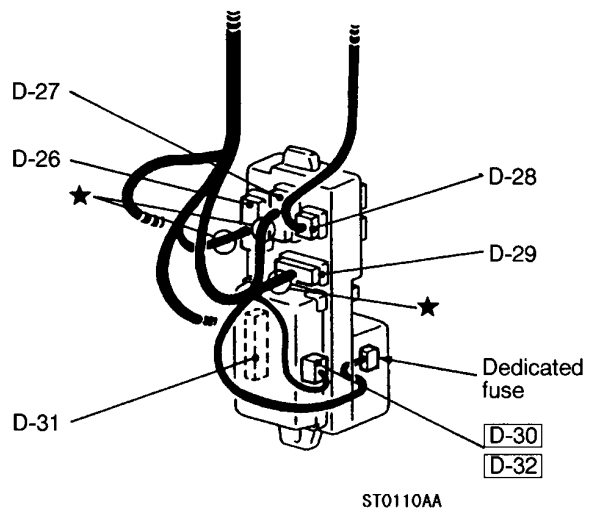

- D-15X (4) Rear heater relay
- D-16X (4) Power window relay
- D-17X (6) Defogger timer
- D-18X (8) Rear intermittent wiper relay
- D-19 (16) Body wiring harness and J/B combination
- D-20 (2) Roof wiring harness and J/B combination
- D-21 (12) Front wiring harness and J/B combination
- D-22 (1) Front wiring harness and J/B combination
- D-23 (5) No connection
- D-24 (5) No connection
- D-25 (3) Turn signal and hazard warning flasher unit
- D-26 (20) Body wiring harness and J/B combination

- D-27 (16-B) Body wiring harness and J/B combination
- D-28 (4) Front wiring harness and J/B combination
- D-29 (8) Body wiring harness and J/B combination
- D-30 (8) ETACS-ECU <Vehicles without keyless entry system>
- D-31 (12) ETACS-ECU
- D-32 (16-B) ETACS-ECU <Vehicles with keyless entry system>

NOTE
Connector numbers enclosed by a frame are newly added or changed.

STEERING COLUMN, JUNCTION BLOCK AND RELAY BOX

R.H. drive vehicles

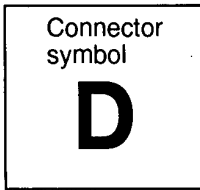

Steering column

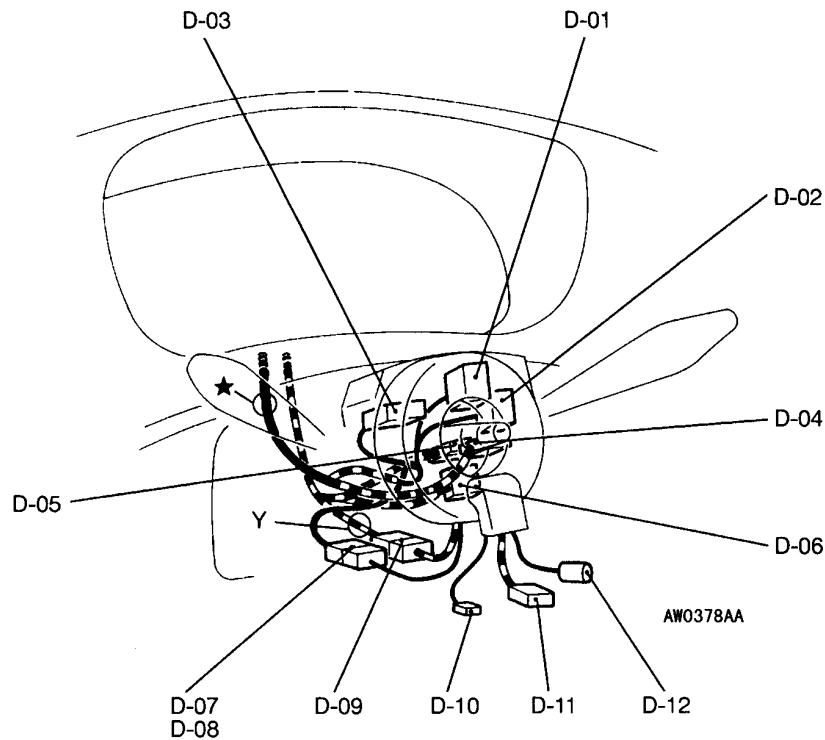

- | | | | |
|------------|--|-------------|--|
| D-01 (6) | Column switch | D-09 (2-R) | Clock spring <SRS> |
| D-02 (12) | Column switch | D-10 (3-Y) | Auto-cruise control switch |
| D-03 (10) | Column switch | D-11 (2) | Air bag module (squib) (driver's side) |
| D-04 (6-B) | Ignition switch | D-12 (1) | Horn switch |
| D-05 (2) | Ignition key ring antenna | D-13X (4) | Accessory socket relay |
| D-06 (7) | Key reminder switch | D-14 (19-B) | Body wiring harness and front wiring harness combination |
| D-07 (3) | Clock spring <Vehicles without auto-cruise control system> | | |
| D-08 (4) | Clock spring <Vehicles with auto-cruise control system> | | |

Relay box in passenger compartment

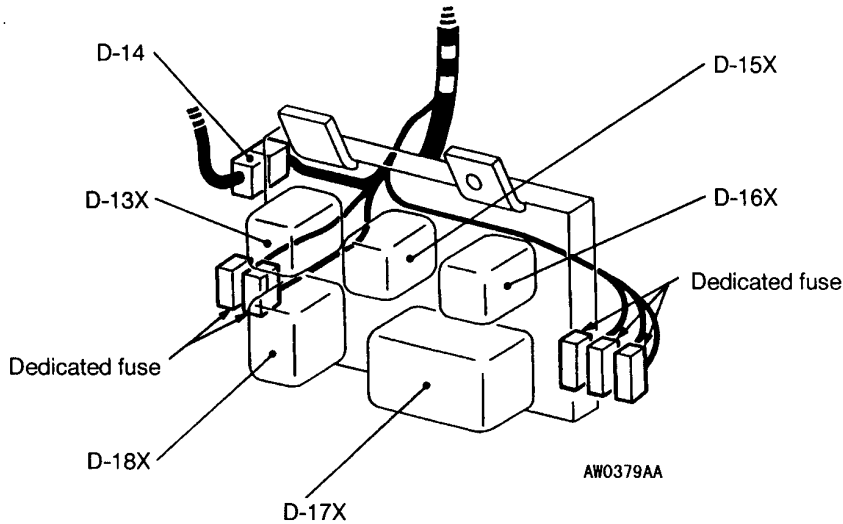

Junction block

<Front side view>

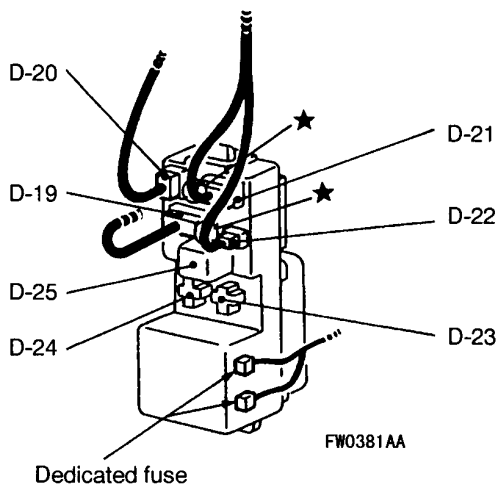

<Rear side view>

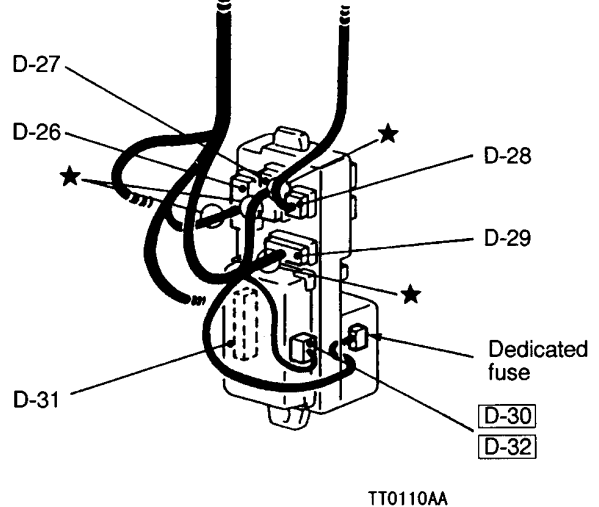

- D-15X (4) Rear heater relay
- D-16X (4) Power window relay
- D-17X (6) Defogger timer
- D-18X (8) Rear intermittent wiper relay
- D-19 (16) Body wiring harness and J/B combination
- D-20 (2) Roof wiring harness and J/B combination
- D-21 (12) Front wiring harness and J/B combination
- D-22 (1) Front wiring harness and J/B combination
- D-23 (15) No connection
- D-24 (5) No connection
- D-25 (3) Turn signal and hazard warning flasher unit
- D-26 (20) Body wiring harness and J/B combination

- D-27 (16-B) Body wiring harness and J/B combination
- D-28 (4) Front wiring harness and J/B combination
- D-29 (8) Body wiring harness and J/B combination
- D-30 (8) ETACS-ECU <Vehicles without keyless entry system>
- D-31 (12) ETACS-ECU
- D-32 (16-B) ETACS-ECU <Vehicles with keyless entry system>

NOTE

Connector numbers enclosed by a frame are newly added or changed.

FLOOR AND ROOF

L.H. drive vehicles

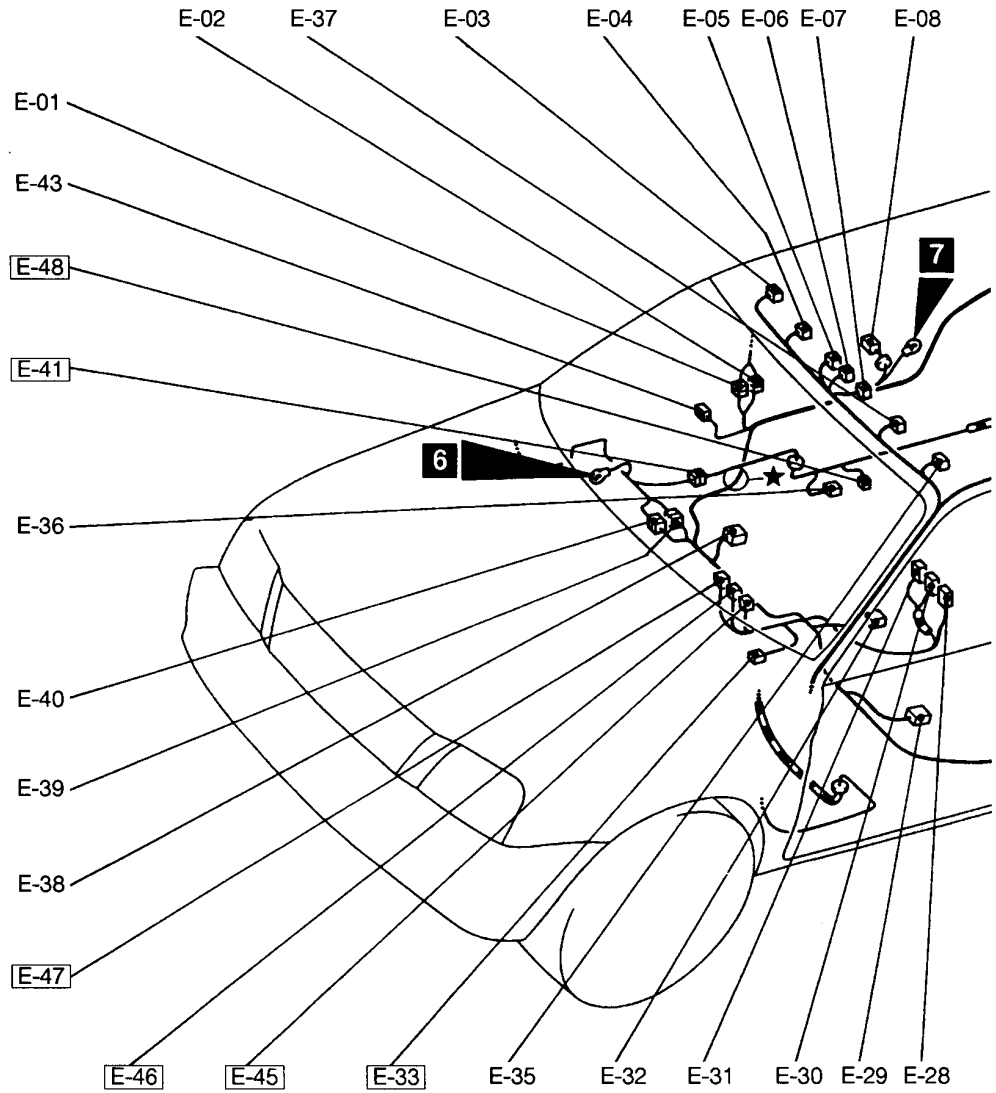
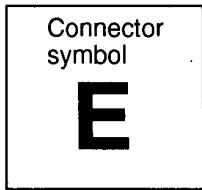

E-01 (5)	Floor wiring harness and rear door wiring harness (RH) combination	E-13 (2)	Rear washer motor
E-02 (6)	Floor wiring harness and rear door wiring harness (RH) combination	E-14 (6-B)	Rear combination lamp (RH)
E-03 (2)	No connection	E-15 (2)	Luggage compartment lamp
E-04 (10)	Sunroof-ECU	E-16 (9)	Roof wiring harness and tailgate wiring harness combination
E-05 (6)	Sunroof switch	E-17 (1)	Roof wiring harness and tailgate wiring harness combination
E-06 (4)	Clock	E-18 (2-BR)	Rear fog lamp (RH)
E-07 (2)	Map lamp <Vehicles without sunroof>	E-19 (2-BR)	Rear fog lamp (LH)
E-08 (1-B)	Rear door switch (RH)	E-20 (6-B)	Rear combination lamp (LH)
E-09 (2-GR)	Room lamp <Vehicles without sunroof>	E-21 (1-B)	Rear door switch (LH)
E-10 (1)	Accessory socket (1)	E-22 (2)	Fuel pump
E-11 (1-B)	Accessory socket (1)	E-23 (2-B)	Wheel speed sensor (rear: LH) <ABS>
E-12 (2-GR)	Room lamp <Vehicles with sunroof>	E-24 (3)	Fuel gauge unit

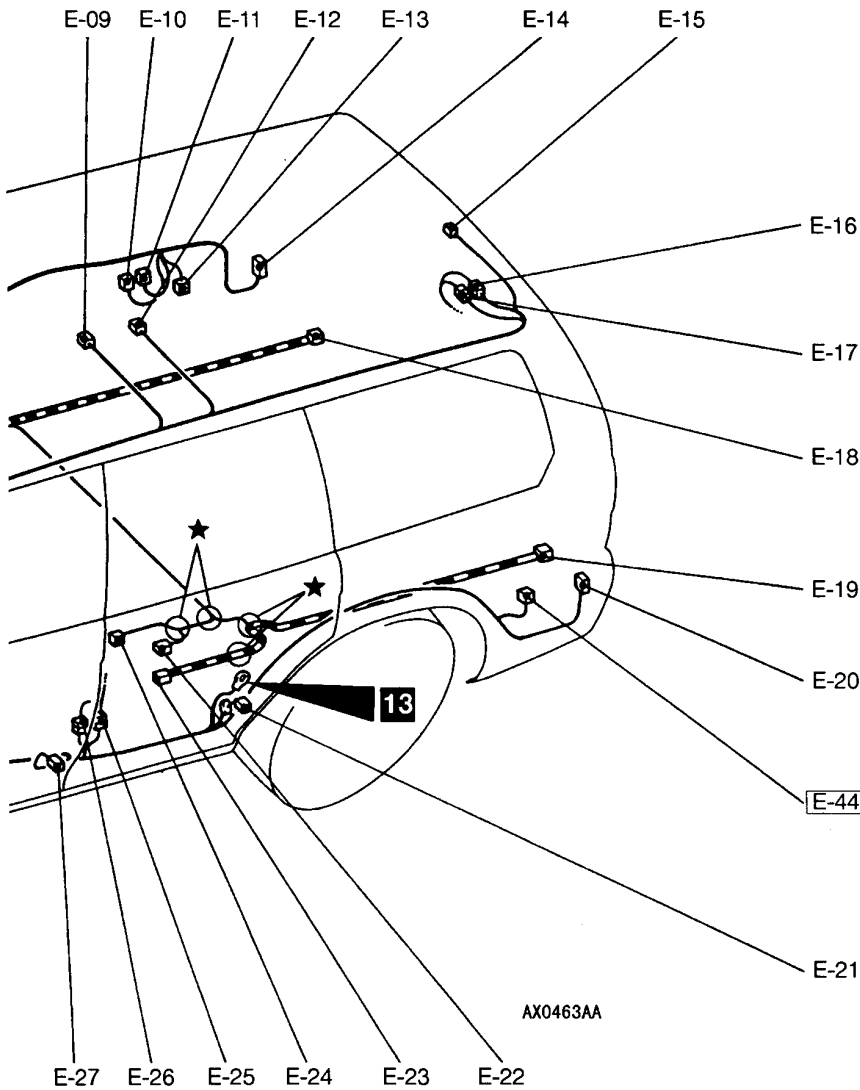

- | | | | |
|-----------------|--|-------------------|--|
| E-25 (5) | Floor wiring harness and rear door wiring harness (LH) combination | E-39 (22) | Body wiring harness and floor wiring harness combination |
| E-26 (6) | Floor wiring harness and rear door wiring harness (LH) combination | E-40 (19) | Body wiring harness and floor wiring harness combination |
| E-27 (2) | Front door switch (LH) | E-41 (16) | Body wiring harness and frame wiring harness combination |
| E-28 (4) | Rear fan motor assembly and resistor | E-43 (2) | Front door switch (RH) |
| E-29 (3-B) | Front seat assembly (LH) | E-44 (6-B) | Keyless entry receiver-ECU |
| E-30 (6) | Rear heater switch | E-45 (1) | Accessory socket (2) |
| E-31 (2) | Rear heater control panel illumination lamp | E-46 (1) | Accessory socket (2) |
| E-32 (1-B) | Parking brake switch | E-47 (6-B) | Motor antenna switch |
| E-33 (9) | Heated seat switch | E-48 (4-B) | Oxygen sensor <A/T> |
| E-35 (2) | No connection | | |
| E-36 (2-B) | Wheel speed sensor (rear: RH) <ABS> | | |
| E-37 (2) | Sunroof motor | | |
| E-38 (3-B) | Front seat assembly (RH) | | |
- NOTE
Connector numbers enclosed by a frame are newly added or changed.

FLOOR AND ROOF

R.H. drive vehicles

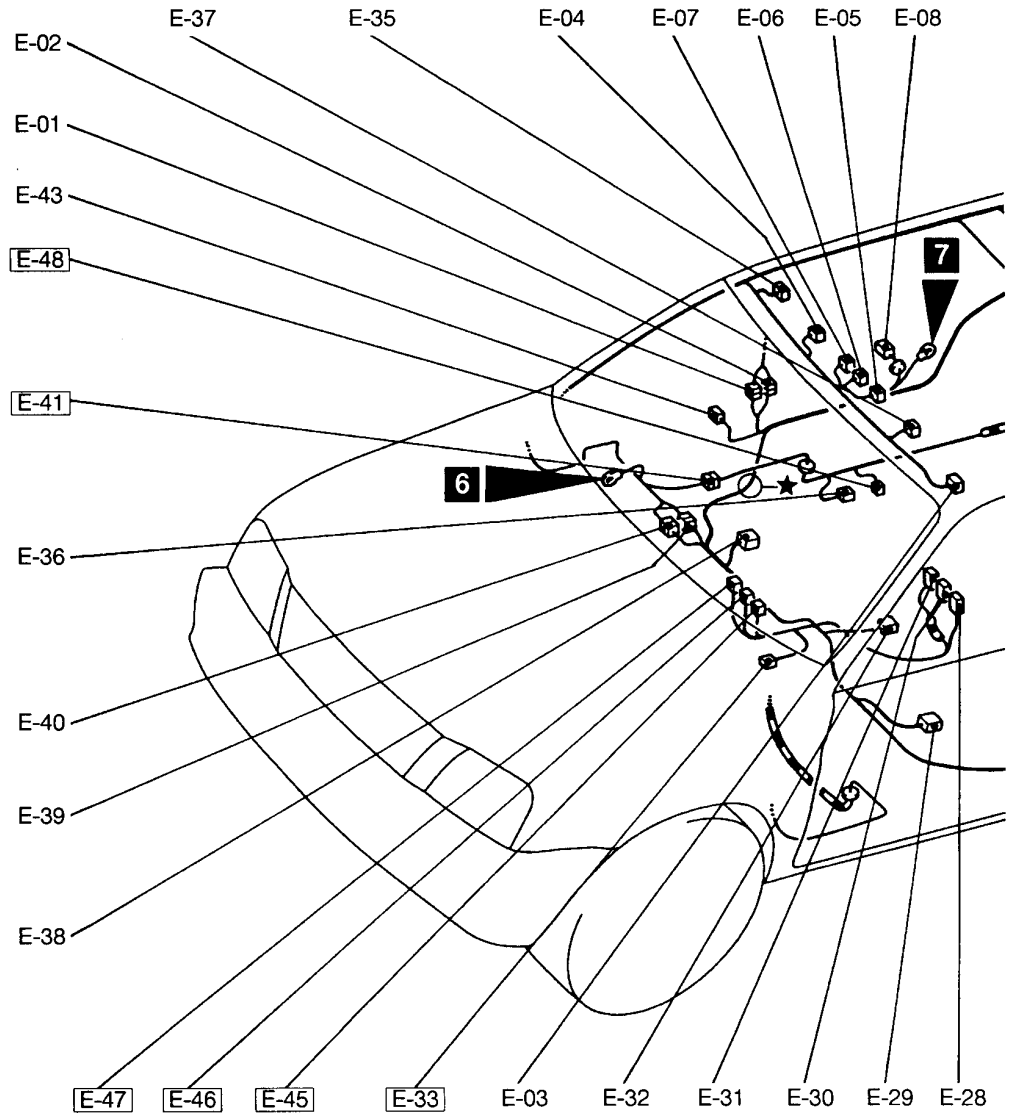
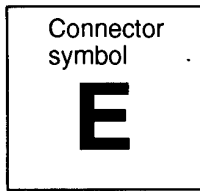

- | | | | |
|-------------|--|-------------|---|
| E-01 (5) | Floor wiring harness and rear door wiring harness (RH) combination | E-13 (2) | Rear washer motor |
| E-02 (6) | Floor wiring harness and rear door wiring harness (RH) combination | E-14 (6-B) | Rear combination lamp (RH) |
| E-03 (2) | No connection | E-15 (2) | Luggage compartment lamp |
| E-04 (10) | Sunroof-ECU | E-16 (9) | Roof wiring harness and tailgate wiring harness combination |
| E-05 (6) | Sunroof switch | E-17 (1) | Roof wiring harness and tailgate wiring harness combination |
| E-06 (4) | Clock | E-18 (2-BR) | Rear fog lamp (RH) |
| E-07 (2) | Map lamp <Vehicles without sunroof> | E-19 (2-BR) | Rear fog lamp (LH) |
| E-08 (1-B) | Rear door switch (RH) | E-20 (6-B) | Rear combination lamp (LH) |
| E-09 (2-GR) | Room lamp <Vehicles without sunroof> | E-21 (1-B) | Rear door switch (LH) |
| E-10 (1) | Accessory socket (1) | E-22 (2) | Fuel pump |
| E-11 (1-B) | Accessory socket (1) | E-23 (2-B) | Wheel speed sensor (rear: LH) <ABS> |
| E-12 (2-GR) | Room lamp <Vehicles with sunroof> | E-24 (3) | Fuel gauge unit |

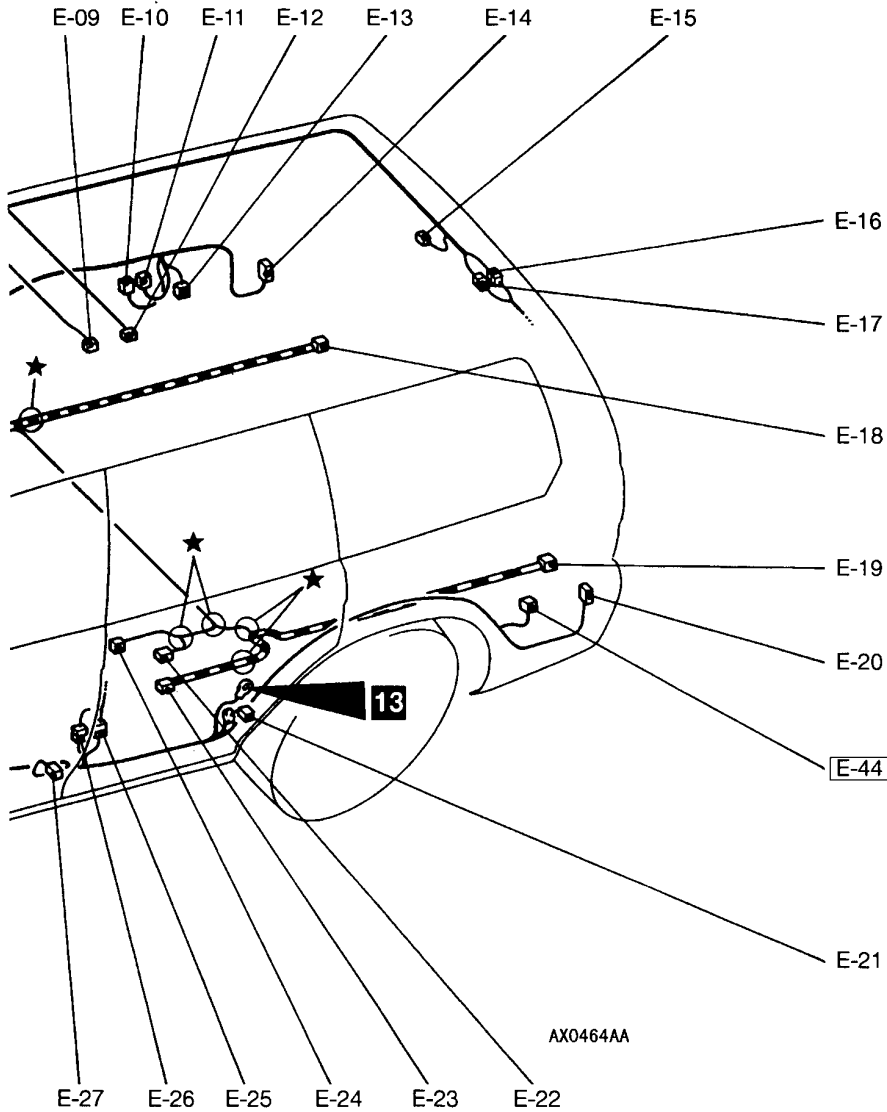

AX0464AA

- | | | | |
|-------------------|--|-------------------|--|
| E-25 (5) | Floor wiring harness and rear door wiring harness (LH) combination | E-39 (22) | Body wiring harness and floor wiring harness combination |
| E-26 (6) | Floor wiring harness and rear door wiring harness (LH) combination | E-40 (19) | Body wiring harness and floor wiring harness combination |
| E-27 (2) | Front door switch (LH) | E-41 (16) | Body wiring harness and frame wiring harness combination |
| E-28 (4) | Rear fan motor assembly and resistor | E-43 (2) | Front door switch (RH) |
| E-29 (3-B) | Front seat assembly (LH) | E-44 (6-B) | Keyless entry receiver-ECU |
| E-30 (6) | Rear heater switch | E-45 (1) | Accessory socket (2) |
| E-31 (2) | Rear heater control panel illumination lamp | E-46 (1) | Accessory socket (2) |
| E-32 (1-B) | Parking brake switch | E-47 (6-B) | Motor antenna switch |
| E-33 (9) | Heated seat switch | E-48 (4-B) | Oxygen sensor <AT> |
| E-35 (2) | No connection | | |
| E-36 (2-B) | Wheel speed sensor (rear: RH) <ABS> | | |
| E-37 (2) | Sunroof motor | | |
| E-38 (3-B) | Front seat assembly (RH) | | |

NOTE

Connector numbers enclosed by a frame are newly added or changed.

DOOR

L.H. drive vehicles

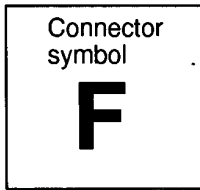

Driver's side

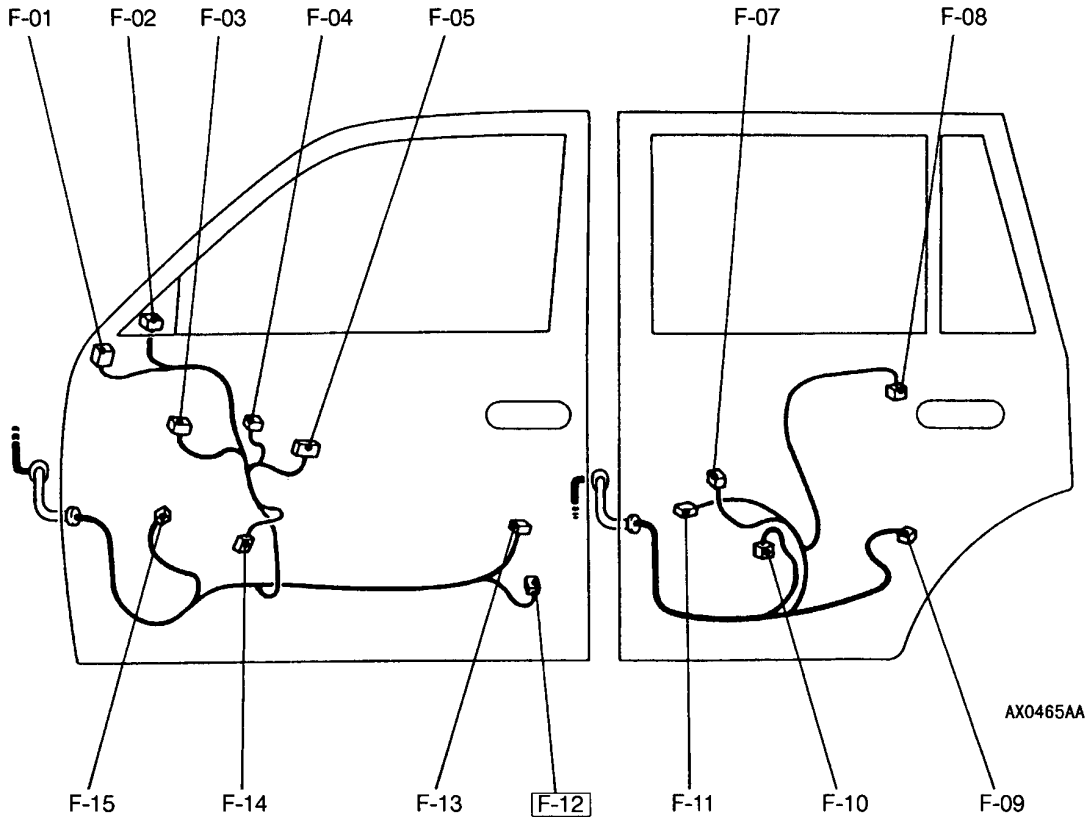

- | | | | |
|-----------|--|------------|---------------------------------------|
| F-01 (7) | Remote controlled mirror (LH) <Vehicles with mirror heater> | F-08 (5) | Door lock actuator (rear: LH) |
| F-02 (3) | Remote controlled mirror (LH) <Vehicles without mirror heater> | F-09 (2-B) | Rear door speaker (LH) |
| F-03 (2) | Power window motor (front: LH) | F-10 (2) | Power window motor (rear: LH) |
| F-04 (9) | Remote controlled mirror switch | F-11 (2) | Power window limit switch (rear: LH) |
| F-05 (10) | Power window main switch | F-12 (2) | Door lamp (LH) |
| F-07 (8) | Power window sub switch | F-13 (6-B) | Door lock actuator (front: LH) |
| | | F-14 (2) | Power window limit switch (front: LH) |
| | | F-15 (2-B) | Front door speaker (LH) |

Passenger's side

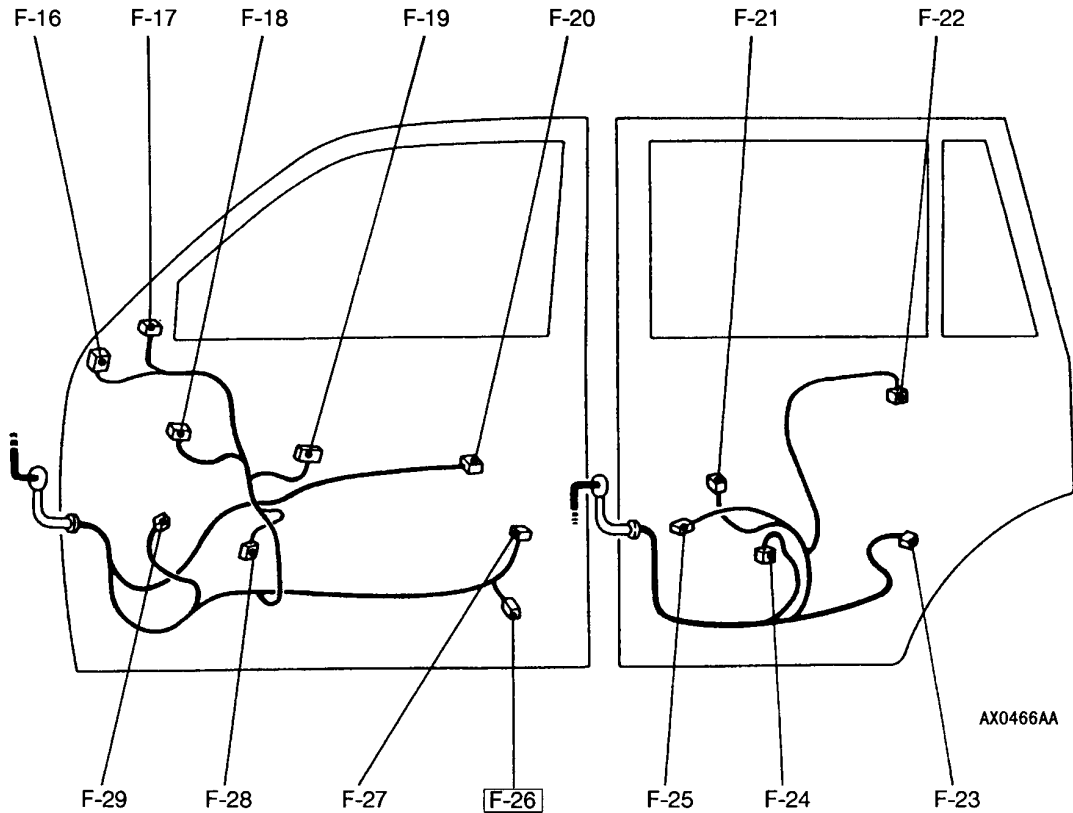

- | | | | |
|------------|--|--|---------------------------------------|
| F-16 (7) | Remote controlled mirror switch (RH)
<Vehicles with mirror heater> | F-24 (2) | Power window motor (rear: RH) |
| F-17 (3) | Remote controlled mirror switch (RH)
<Vehicles without mirror heater> | F-25 (2) | Power window limit switch (rear: RH) |
| F-18 (2) | Power window motor (front: RH) | F-26 (2) | Door lamp (RH) |
| F-19 (8) | Power window sub switch (front passenger's side) | F-27 (6-B) | Door lock actuator (front: RH) |
| F-20 (3) | Door lock key cylinder switch (RH) | F-28 (2) | Power window limit switch (front: RH) |
| F-21 (8) | Power window sub switch | F-29 (2-B) | Front door speaker (RH) |
| F-22 (5) | Door lock actuator (rear: RH) | | |
| F-23 (2-B) | Rear door speaker (RH) | | |

NOTE
Connector numbers enclosed by a frame are relocated.

DOOR

R.H. drive vehicles

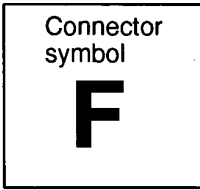

Driver's side

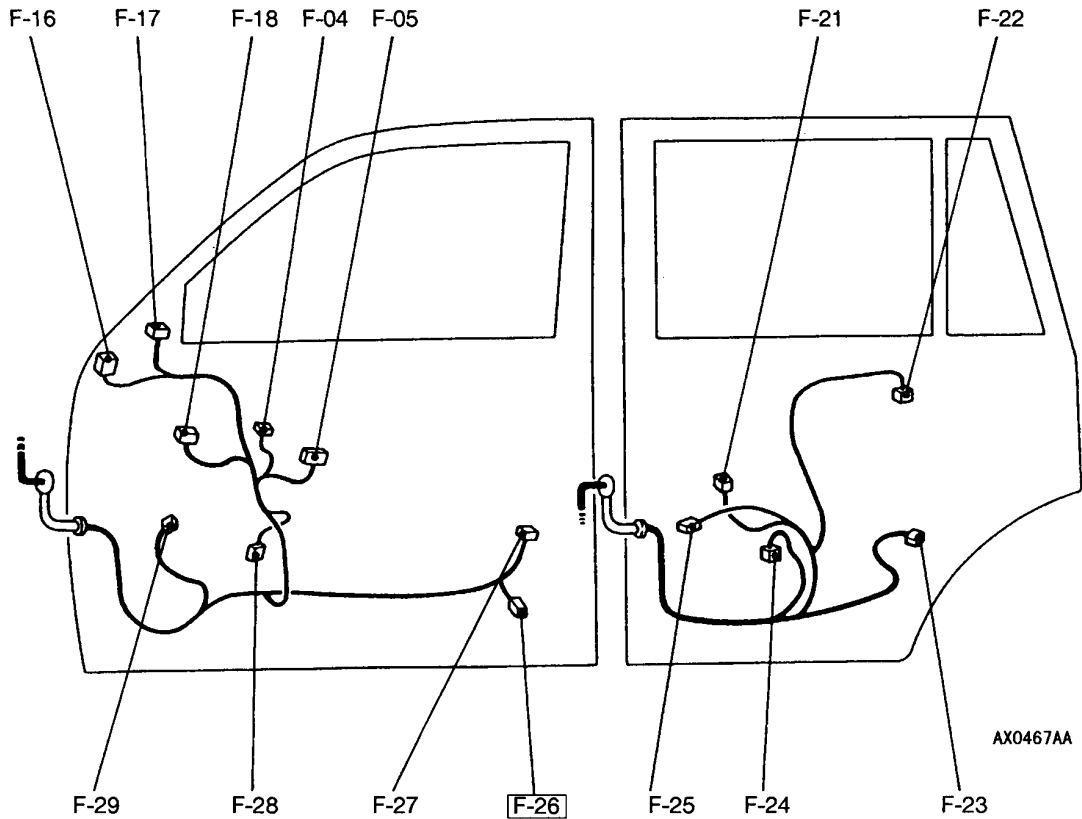

- F-01 (7) Remote controlled mirror (LH) <Vehicles with mirror heater>
- F-02 (3) Remote controlled mirror (LH) <Vehicles without mirror heater>
- F-03 (2) Power window motor (front: LH)
- F-04 (9) Remote controlled mirror switch
- F-05 (10) Power window main switch
- F-06 (3) Door lock key cylinder switch (LH)
- F-07 (8) Power window sub switch

- F-08 (5) Door lock actuator (rear: LH)
- F-09 (2-B) Rear door speaker (LH)
- F-10 (2) Power window motor (rear: LH)
- F-11 (2) Power window limit switch (rear: LH)
- F-12 (2) Door lamp (LH)
- F-13 (6-B) Door lock actuator (front: LH)
- F-14 (2) Power window limit switch (front: LH)
- F-15 (2-B) Front door speaker (LH)

Passenger's side

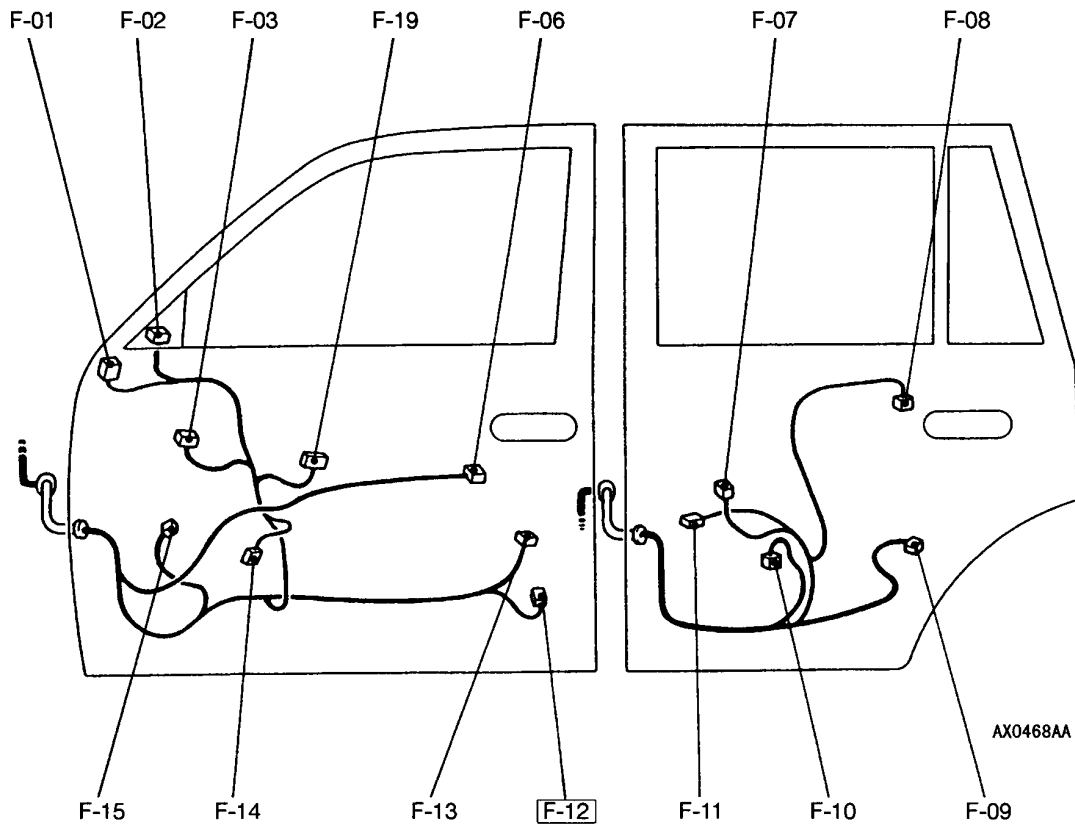

- F-16 (7) Remote controlled mirror switch (RH)
<Vehicles with mirror heater>
- F-17 (3) Remote controlled mirror switch (RH)
<Vehicles without mirror heater>
- F-18 (2) Power window motor (front: RH)
- F-19 (8) Power window sub switch (front passenger's side)
- F-21 (8) Power window sub switch
- F-22 (5) Door lock actuator (rear: RH)
- F-23 (2-B) Rear door speaker (RH)

- F-24 (2) Power window motor (rear: RH)
- F-25 (2) Power window limit switch (rear: RH)
- F-26 (2) Door lamp (RH)
- F-27 (6-B) Door lock actuator (front: RH)
- F-28 (2) Power window limit switch (front: RH)
- F-29 (2-B) Front door speaker (RH)

NOTE
Connector numbers enclosed by a frame are relocated.

SINGLE PART INSTALLATION POSITION

CONTENTS

RELAY	3-2	SOLENOID VALVE	3-5
ECU	3-3	DIODE	3-5
SENSOR	3-4		



RELAY

Name	Symbol	Name	Symbol
A/T control relay	B	Engine oil level relay	C
Defogger relay	A	Rear fog lamp relay	A
Hazard warning relay <with keyless entry>	A		

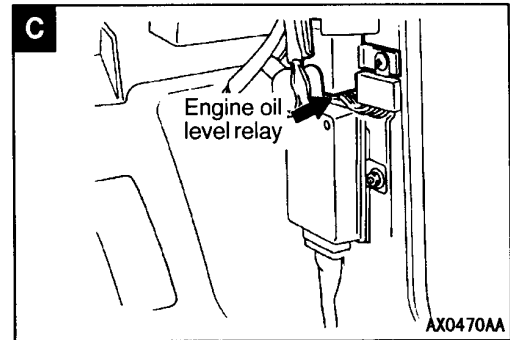
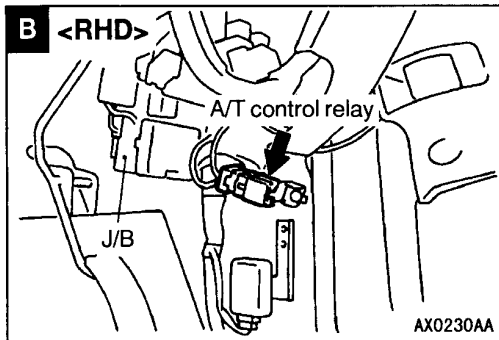
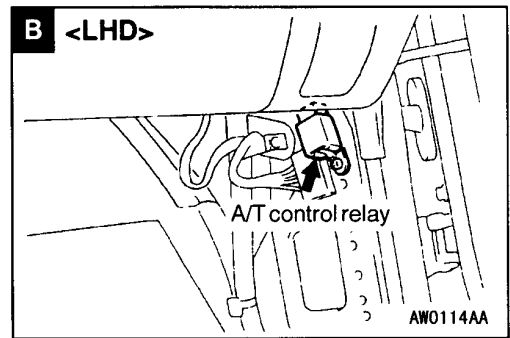
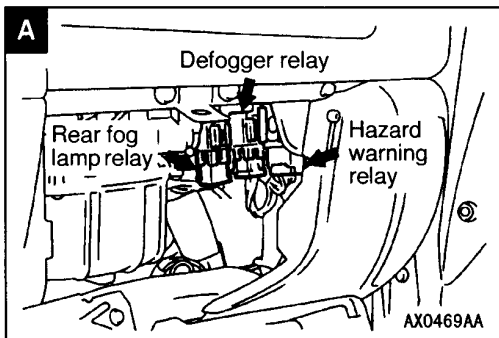
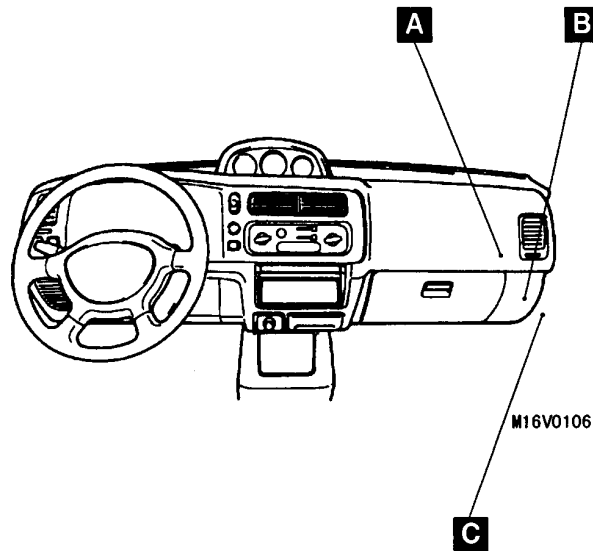

ECU

Name	Symbol	Name	Symbol
Engine-A/T-ECU <Petrol-A/T>	B	Keyless entry receiver-ECU	C
Motor antenna-ECU	A		

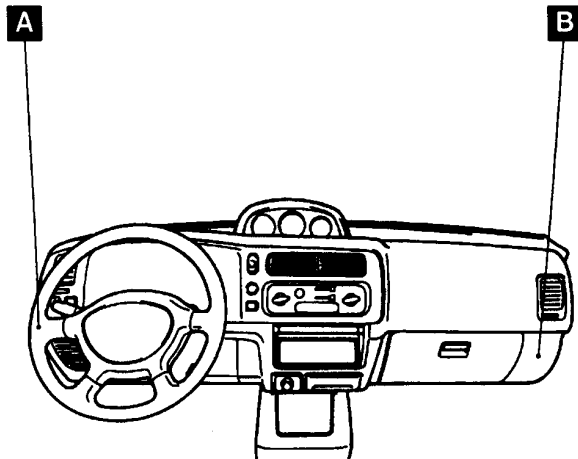

N16V0106

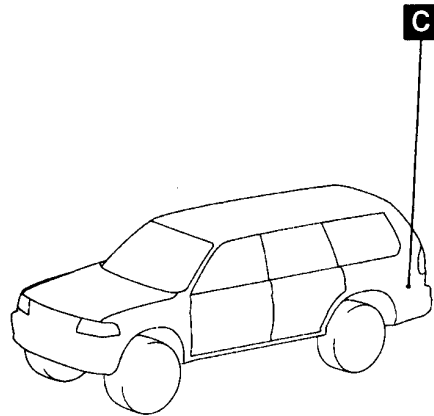

E00V0062

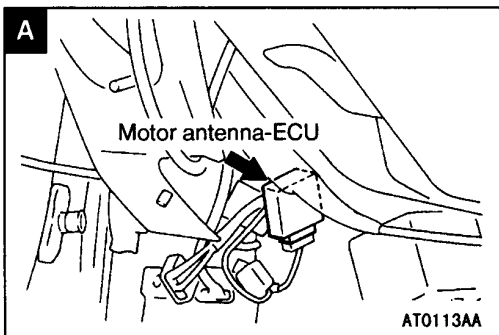

AT0113AA

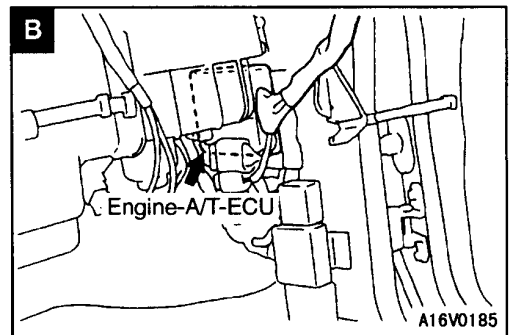

A16V0185

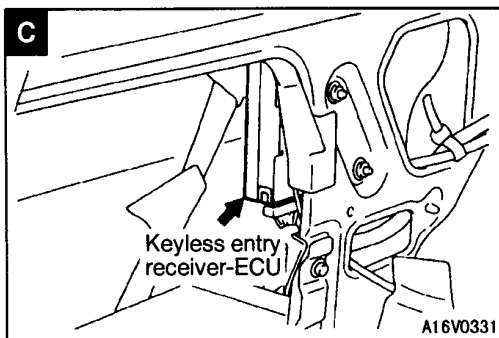

A16V0331

SENSOR

Name	Symbol	Name	Symbol
A/T fluid temperature sensor	B	Output shaft speed sensor <A/T>	C
Input shaft speed sensor <A/T>	A	Oxygen sensor <A/T>	E
		Oxygen sensor <M/T>	D

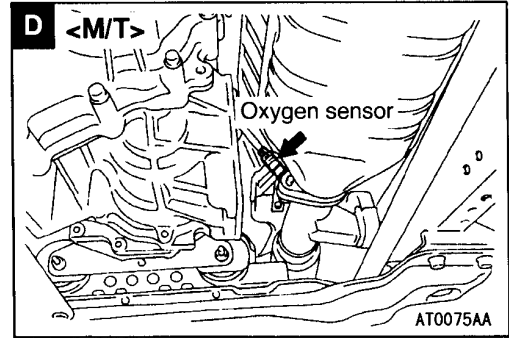
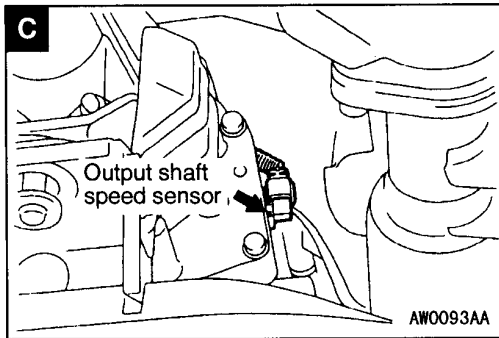
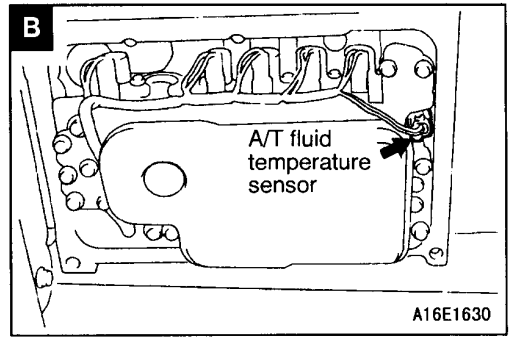
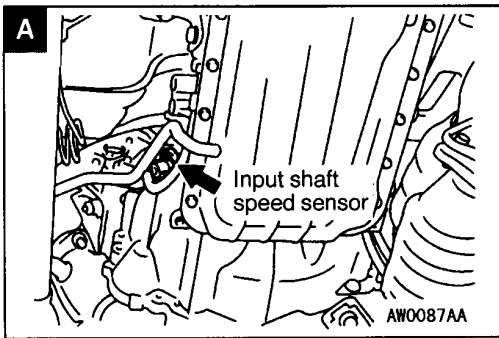
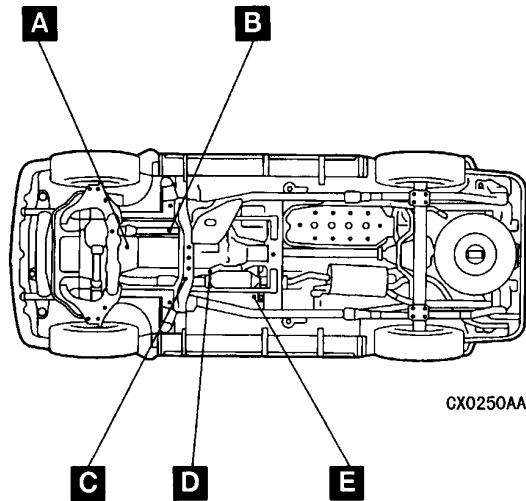

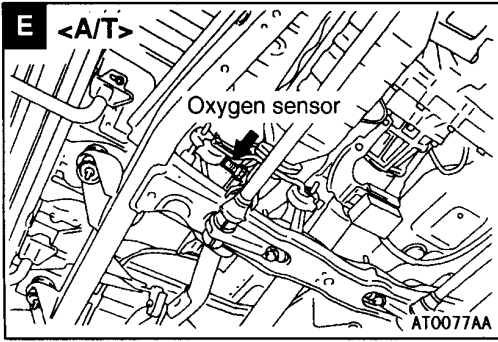

SOLENOID VALVE

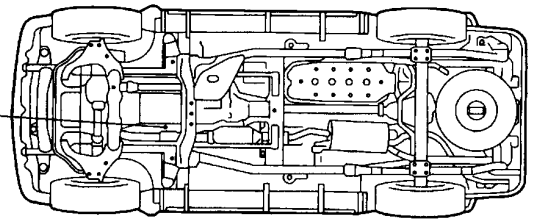
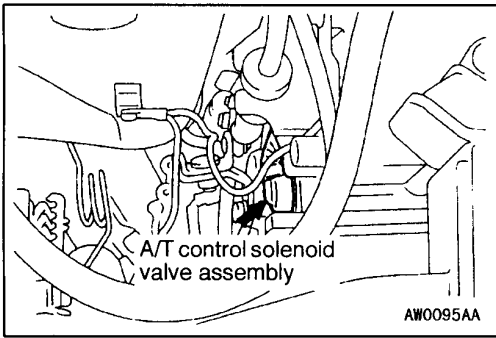

DIODE

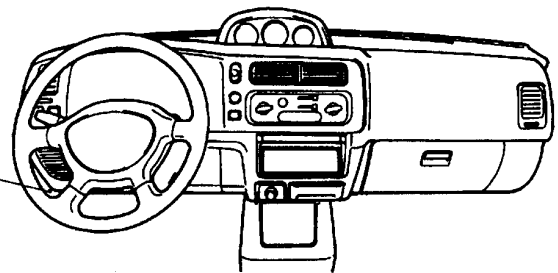
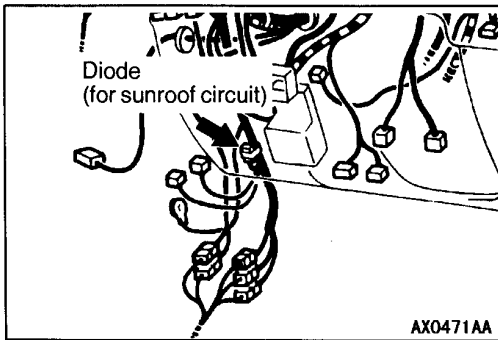

CIRCUIT DIAGRAM

CONTENTS

JOINT CONNECTOR (J/C)	4-4	HEADLAMP LEVELING SYSTEM	4-60
CENTRALIZED JUNCTION	4-8	ROOM LAMP, MAP LAMP AND LUGGAGE COMPARTMENT LAMP	
STARTING SYSTEM		Vehicles with keyless entry system	4-62
M/T	4-12	Vehicles without keyless entry system	4-66
A/T	4-13	IGNITION KEY CYLINDER ILLUMINATION LAMP	
IGNITION SYSTEM	4-14	L.H. drive vehicles	4-68
GLOW SYSTEM	4-15	R.H. drive vehicles	4-69
ENGINE CONTROL SYSTEM		DOOR LAMP	
MPI-M/T	4-16	L.H. drive vehicles	4-70
MPI-A/T	4-24	R.H. drive vehicles	4-71
Diesel	4-32	TURN-SIGNAL LAMP AND HAZARD WARNING LAMP	4-72
INVECS-II 4A/T	4-34	STOP LAMP	4-74
TAIL LAMP, POSITION LAMP AND LICENCE PLATE LAMP		BACK-UP LAMP	4-76
L.H. drive vehicles	4-44	HORN	4-77
R.H. drive vehicles	4-46	METER AND GAUGE	4-78
FRONT FOG LAMP		BRAKE WARNING LAMP	4-82
L.H. drive vehicles	4-48	FUEL WARNING LAMP	4-82
R.H. drive vehicles	4-50	OIL PRESSURE WARNING LAMP	4-83
REAR FOG LAMP		FUEL FILTER WARNING LAMP	4-83
L.H. drive vehicles	4-52		
R.H. drive vehicles	4-56		
GLOVE BOX LAMP	4-59		

CENTRAL DOOR LOCKING SYSTEM

- L.H. drive vehicles with keyless entry system 4-84
- L.H. drive vehicles without keyless entry system 4-94
- R.H. drive vehicles with keyless entry system 4-98
- R.H. drive vehicles without keyless entry system 4-108

POWER WINDOWS 4-112**HEATER**

- Petrol-powered vehicles 4-116
- Diesel-powered vehicles 4-118

AIR CONDITIONER

- Petrol-powered vehicles 4-120
- Diesel-powered vehicles 4-124

REAR HEATER 4-128**REAR WIPER AND WASHER 4-132****HEADLAMP WASHER 4-134****RADIO AND TAPE PLAYER 4-136****ACCESSORY SOCKET 4-139****ANTI-SKID BRAKING SYSTEM (ABS) 4-140****SUPPLEMENTAL RESTRAINT SYSTEM (SRS) 4-146****AUTO-CRUISE CONTROL SYSTEM 4-148****PART TIME 4WD SYSTEM 4-154****SUNROOF 4-156****IMMOBILIZER SYSTEM**

- Petrol-powered vehicles 4-158

LIGHTING MONITOR BUZZER

- L.H. drive vehicles 4-160
- R.H. drive vehicles 4-162

HEATED SEAT 4-164**RHEOSTAT 4-166****FUEL LINE HEATER 4-167****INTERCOOLER FAN 4-168**

NOTES

JOINT CONNECTOR (J/C)

NOTE
 IN ACTUAL VEHICLES, ANY OF THE TERMINALS CONNECTED IN J/C ARE USED.
 THE TERMINALS DESCRIBED IN THE CIRCUIT DIAGRAM MAY NOT BE
 IDENTICAL TO THOSE OF THE VEHICLES.

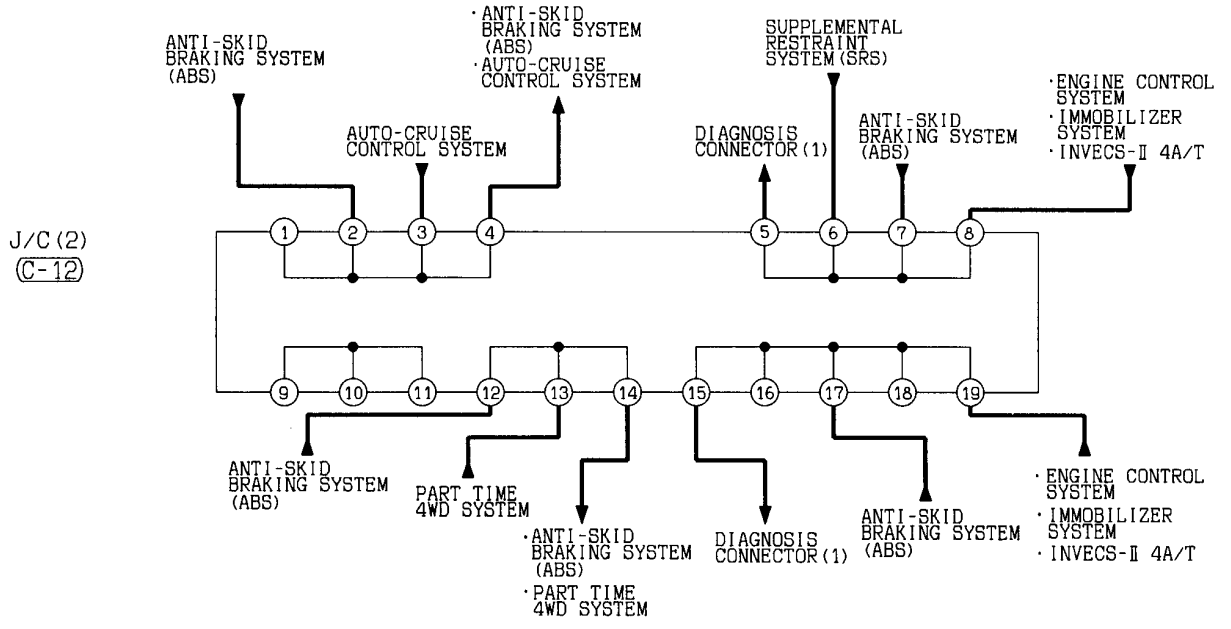
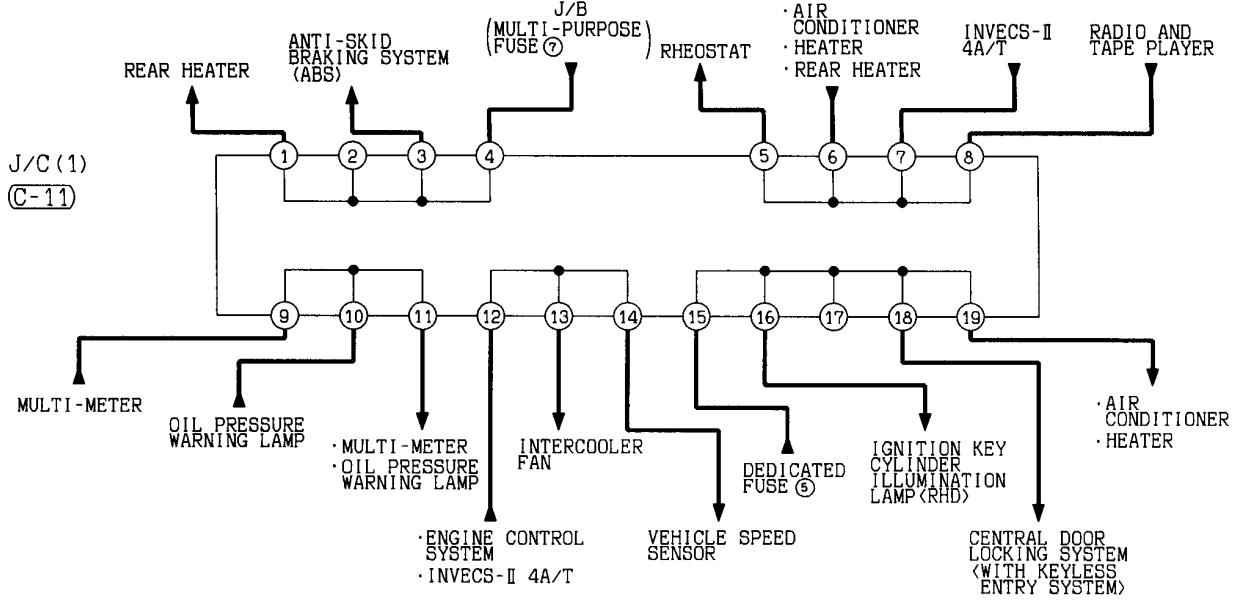

(C-11)

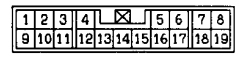

(C-12)

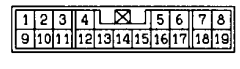

(C-68)



(C-71)



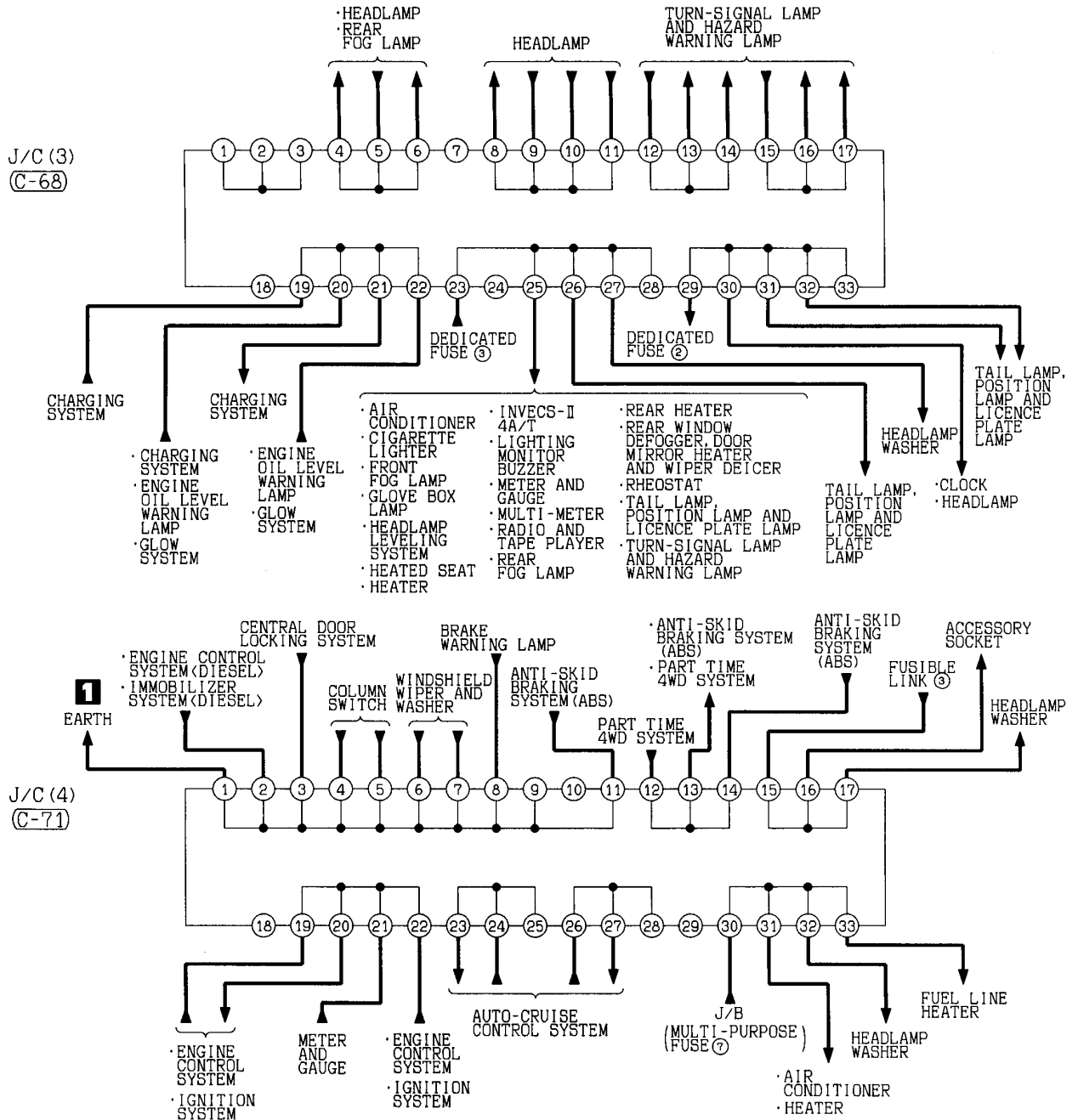

JOINT CONNECTOR (CONTINUED)

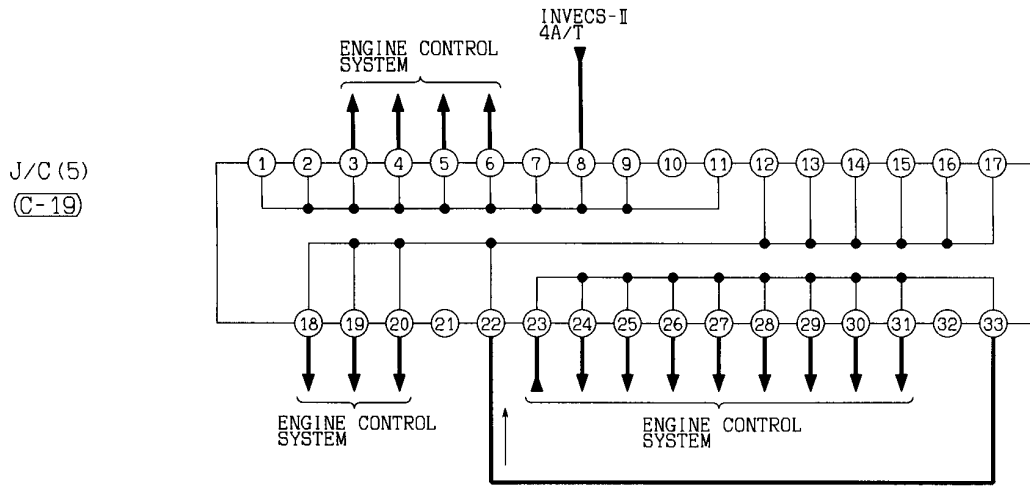

(C-19)

1	2	3	4	5	6	7	8	9	10	11
12	13	14	15	16	17	18	19	20	21	22
23	24	25	26	27	28	29	30	31	32	33

NOTES

CENTRALIZED JUNCTION**DEDICATED FUSE (Relay box in engine compartment)**

Power supply circuit	No.	Rated capacity (A)	Housing colour	Circuit
Battery/Alternator (Fusible link No.1)	1	10	Red	Hazard warning lamp, keyless entry system and immobilizer system
Tail lamp relay <LHD> Column switch <RHD> (Fusible link No.3)	2	10	Red	Tail lamp, daytime running lamp <LHD> and clock
	3	10	Red	Tail lamp and illumination
Headlamp relay (Fusible link No.3)	4	10	Red	High beam indicator
Battery/Alternator (Fusible link No.6)	5	10	Red	Clock, radio, room lamp, door lamp, combination meter, multi-meter, ECU-power supply and MUT-II power supply
Battery/Alternator (Fusible link No.7)	6	20	Yellow	Condenser fan motor
	7	10	Red	A/C compressor
Battery/Alternator (Fusible link No.6)	8	10	Red	Stop lamp
Ignition switch (ACC)	9	10	Red	Daytime running lamp <LHD> and horn
Ignition switch (IG2)	10	10	Red	Heated seat and power window
	11	—	—	—
Battery/Alternator (Fusible link No.6)	12	15	Blue	Fuel line heater
Battery/Alternator (Fusible link No.6)	13	10	Red	Sunroof
Defogger relay (Fusible link No.6)	14	10	Red	Door mirror heater
Battery/Alternator (Fusible link No.6)	15	15	Blue	Accessory socket
Battery/Alternator (Fusible link No.7)	16	15	Blue	Rear heater
Battery/Alternator (Fusible link No.6)	17	25	Transparent	Defogger and dedicated fuse No. (14)
Battery/Alternator (Fusible link No.3)	18	15	Blue	Front fog lamp and rear fog lamp

(Relay box in engine compartment)

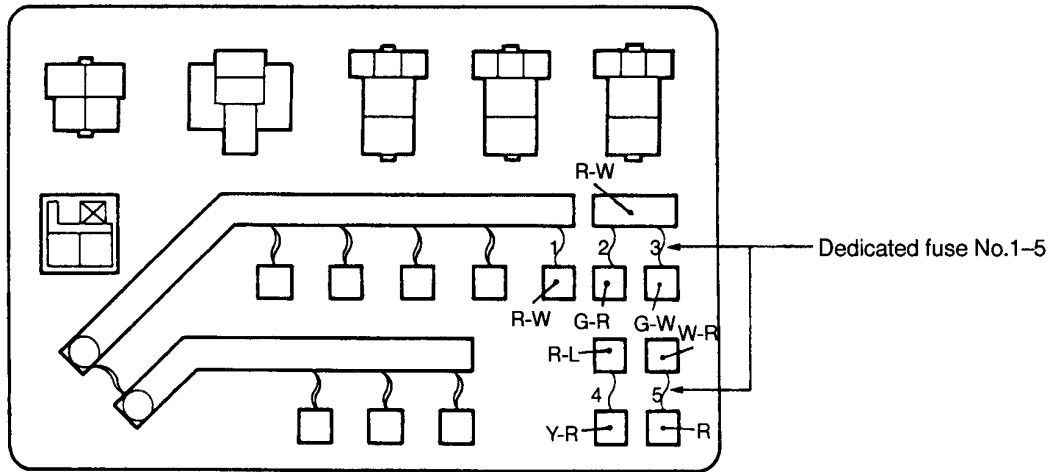

C16S0162

(A/C relay bracket in engine compartment)

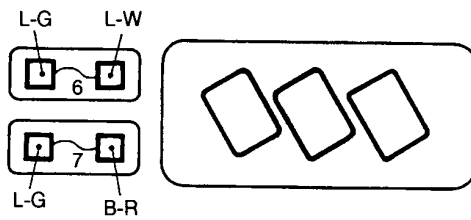

A16V0067

(In junction block)

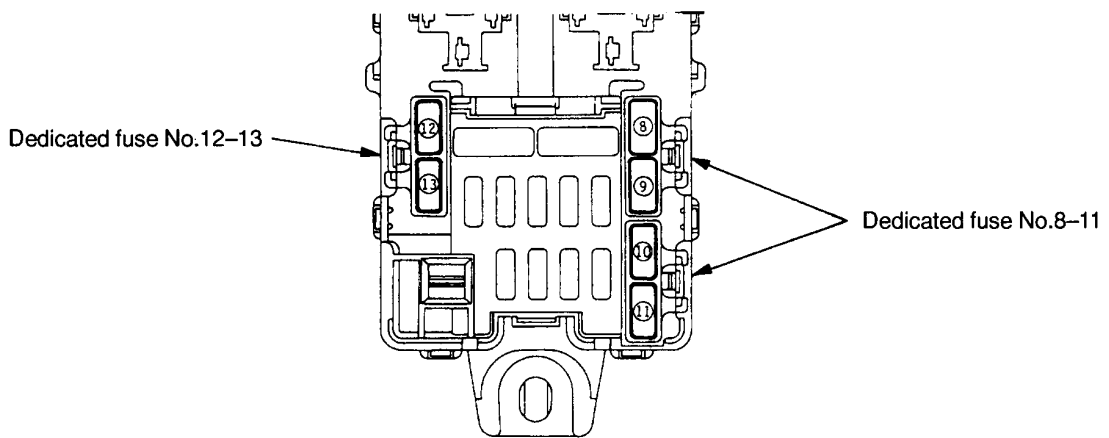

BV0017AA

(Relay box in passenger compartment)

<L.H. drive vehicles>

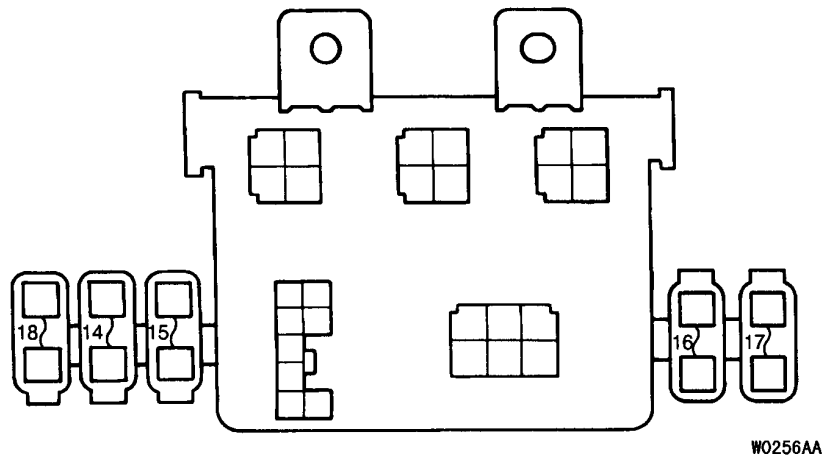

<R.H. drive vehicles>

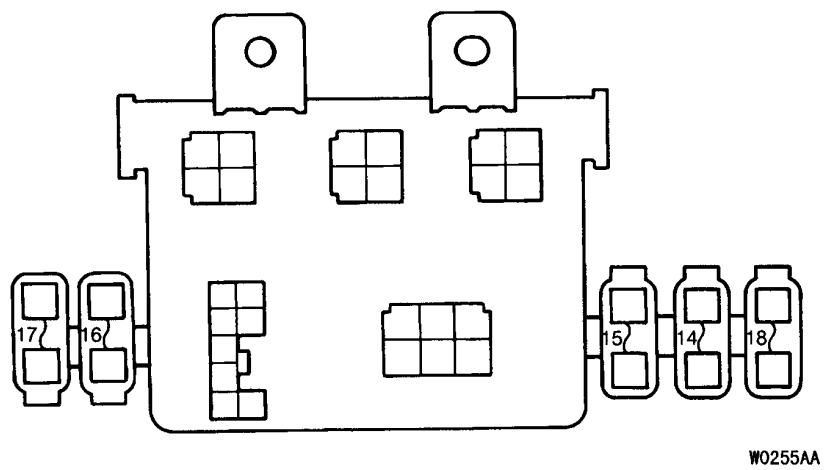

MULTI-PURPOSE FUSE (In junction block)

Power supply circuit	No.	Rated capacity (A)	Housing colour	Load circuit	
Battery	1	–	–	–	
	2	–	–	–	
Ignition switch	IG1	3	10	Red	Turn signal and hazard warning flasher unit
	ACC	4	10	Red	Clock, radio, accessory socket, keyless entry receiver-ECU, motor antenna-ECU and auto-cruise control switch
Battery	5	–	–	–	–
	6	15	Blue	Blue	ETACS-ECU
Ignition switch	IG2	7	10	Red	ABS-ECU, ABS relay, defogger relay, DRL relay, dim-dip lamp relay, G sensor, headlamp washer relay, blower relay, A/C switch, condenser fan control relay, defogger timer, defogger switch and rear heater relay
	ACC	8	15	Blue	Cigarette lighter and remote controlled mirror
	ACC	9	15	Blue	Intermittent wiper relay, washer motor and wiper motor
	IG1	10	10	Red	Back-up lamp, combination meter, engine-A/T-ECU, input shaft speed sensor, output shaft speed sensor and SRS-ECU
	IG1	11	10	Red	Auto-cruise control-ECU, combination meter, ETACS-ECU, immobilizer-ECU, multi-meter, 4WD indicator-ECU, SRS-ECU, sunroof-ECU, motor antenna-ECU and vehicle speed sensor

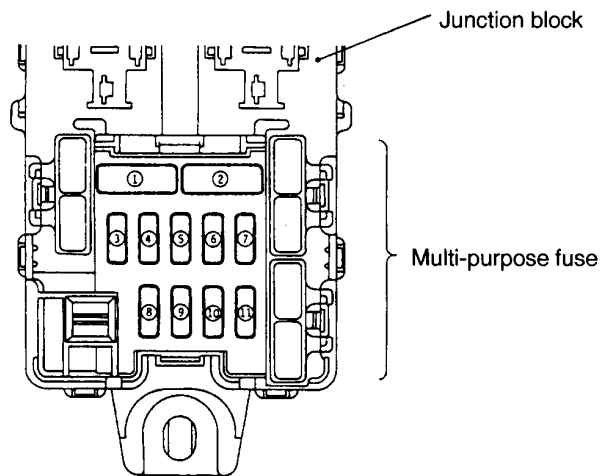

A16V0071

STARTING SYSTEM

M/T

1

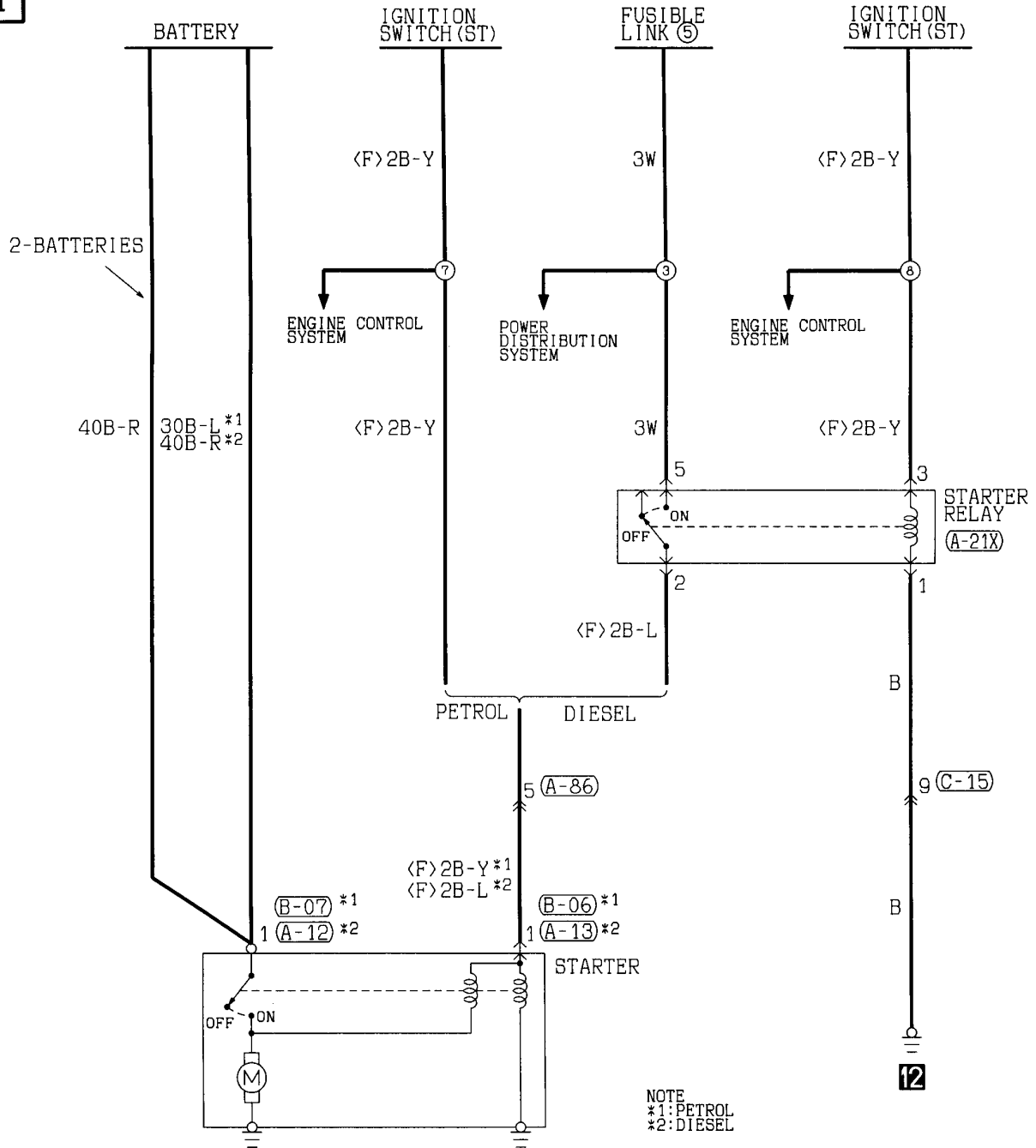

NOTE
*1: PETROL
*2: DIESEL

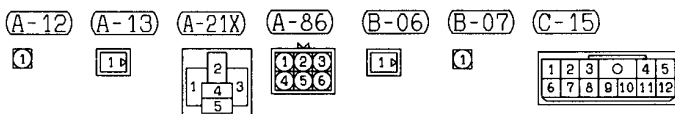

Wire colour code
 B :Black LG:Light green G :Green L :Blue W :White Y :Yellow SB:Sky blue
 BR:Brown O :Orange GR:Gray R :Red P :Pink V :Violet

STARTING SYSTEM

A/T

1

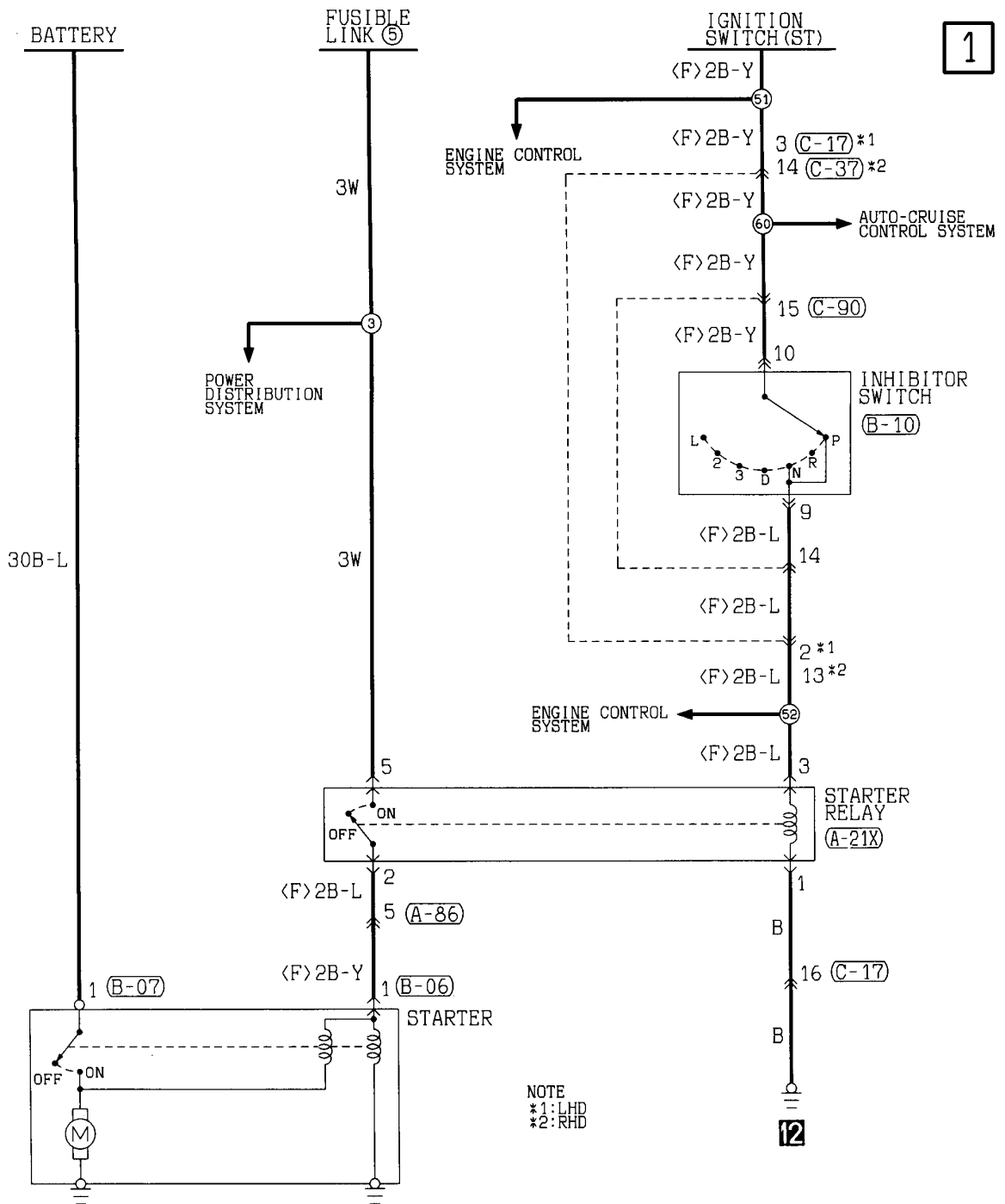

NOTE
*1: LHD
*2: RHD

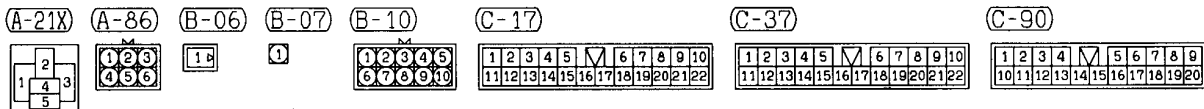

Wire colour code
 B : Black LG: Light green G : Green L : Blue W : White Y : Yellow SB: Sky blue
 BR: Brown O : Orange GR: Gray R : Red P : Pink V : Violet

IGNITION SYSTEM

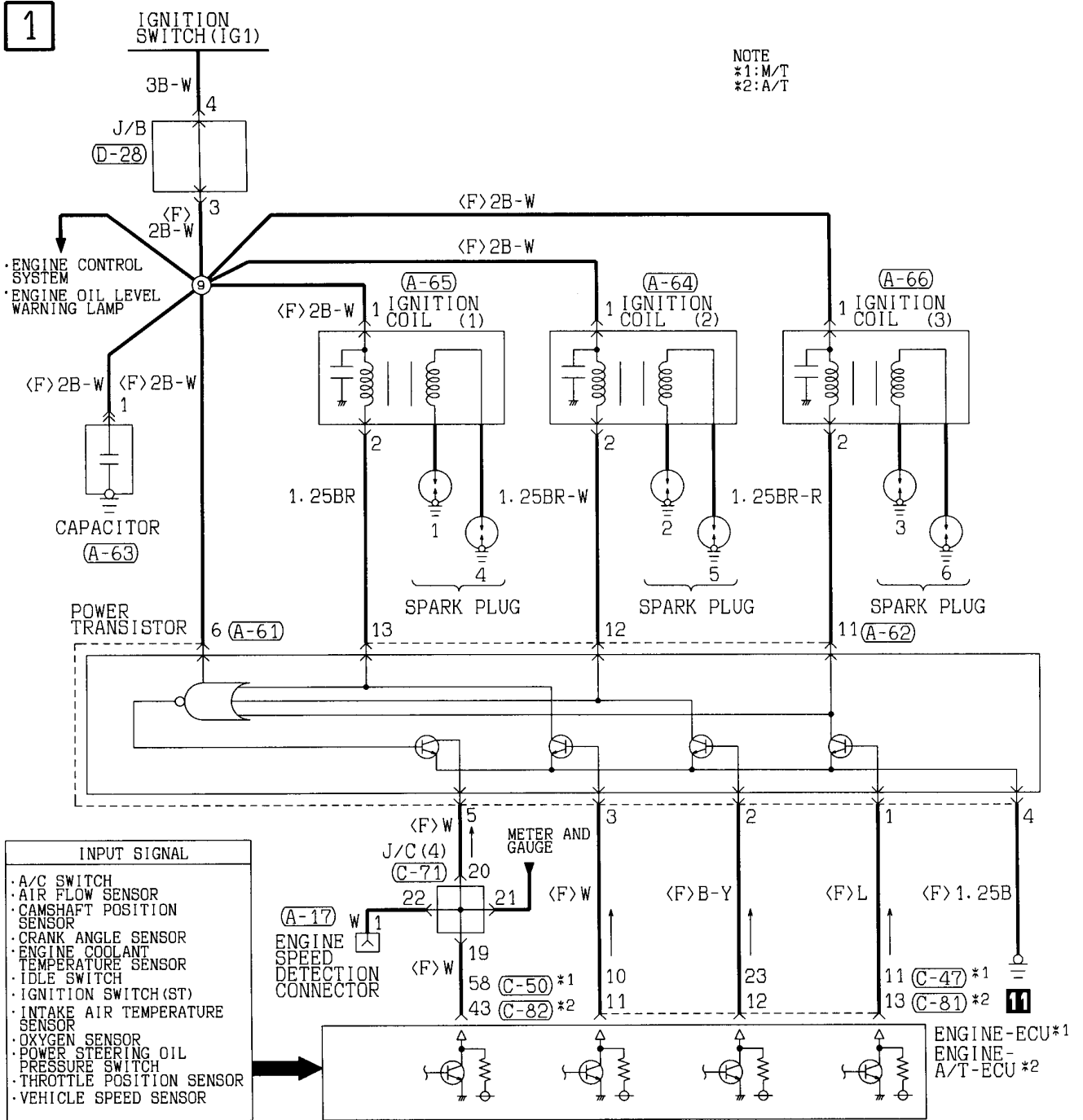

(A-17)	(A-61)	(A-62)	(A-63)	(A-64)	(A-65)	(A-66)	(C-47)	(C-50)
1	023456	1123	1	12	12	12	1 2 3 4 5 6 7 8 9 10 11 12 13 14 15 16 17 18 19 20 21 22 23 24 25 26	51 52 53 54 55 56 57 58 59 60 61 62
(C-71)	(C-81)	(C-82)	(D-28)					
1 2 3 4 5 6 7 8 9 10 11 12 13 14 15 16 17 18 19 20 21 22 23 24 25 26 27 28 29 30 31 32 33	1 2 3 4 5 6 7 8 9 10 11 12 13 14 15 16 17 18 19 20 21 22 23 24 25 26 27 28 29 30 31 32 33 34 35	41 42 43 44 45 46 47 48 49 50 51 52 53 54 55 56 57 58 59 60 61 62 63 64 65 66	1 2 3 4					

GLOW SYSTEM

1

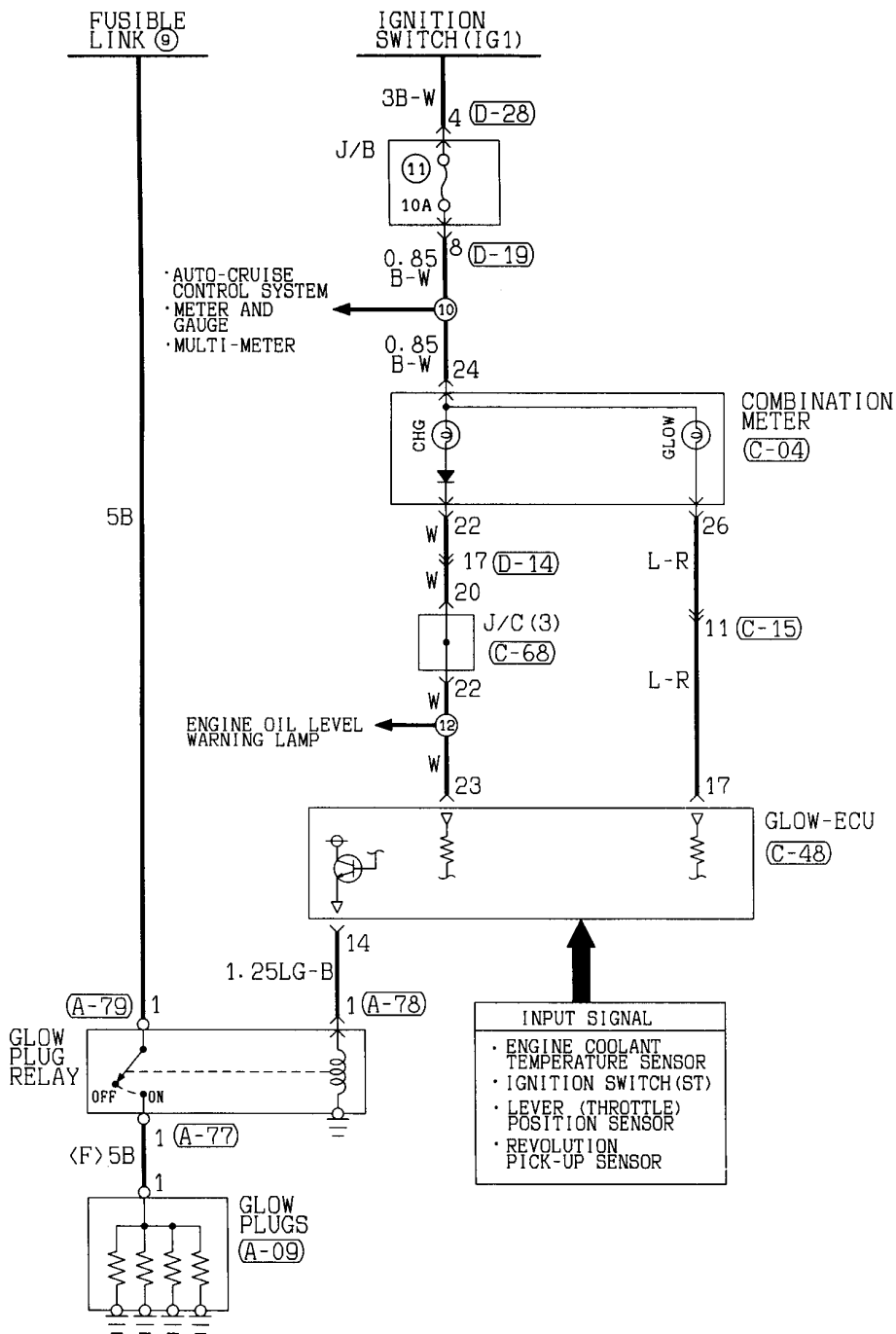

(A-09)	(A-77)	(A-78)	(A-79)	(C-04)	(C-15)	(C-48)	(C-68)
①	①	①	①	①	①	①	①
①	①	①	①	①	①	①	①
(D-14)	(D-19)	(D-28)	Wire colour code				
①	①	①	B:Black	LG:Light green	G:Green	L:Blue	
①	①	①	BR:Brown	O:Orange	GR:Gray	R:Red	
①	①	①	W:White	SB:Sky blue	P:Pink	Y:Yellow	
①	①	①	V:Violet				

ENGINE CONTROL SYSTEM

MPI-M/T

1

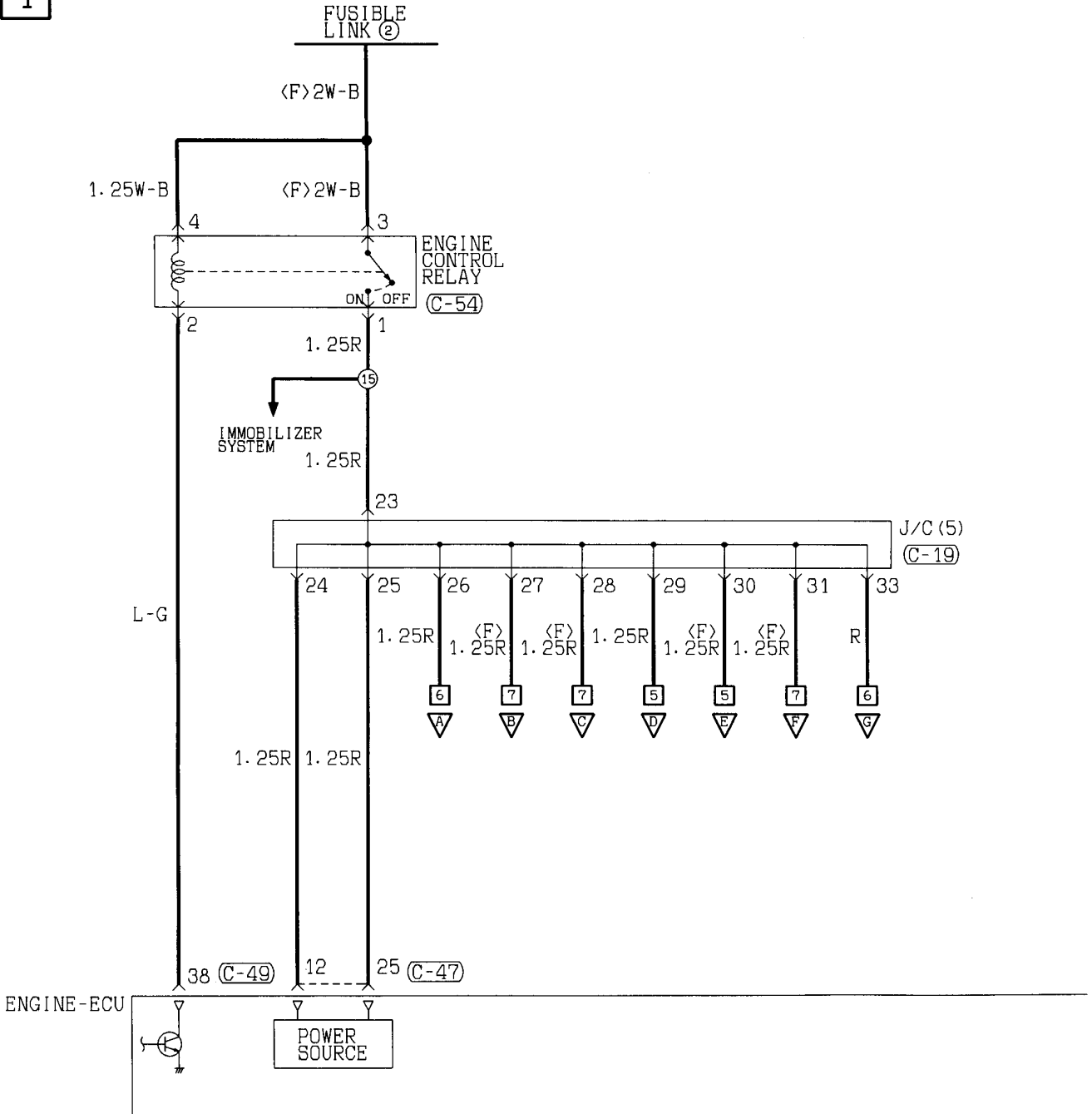

(A-63)

(C-17)

(C-19)

(C-47)

(C-49)

(C-51)



1	2	3	4	5	6	7	8	9	10
11	12	13	14	15	16	17	18	19	20
21	22								

1	2	3	4	5	6	7	8	9	10
11	12	13	14	15	16	17	18	19	20
21	22	23	24	25	26	27	28	29	30
31	32	33							

1	2	3	4	5	6	7	8	9	10
11	12	13	14	15	16	17	18	19	20
21	22	23	24	25	26				

31	32	33	34	35	36	37	38
39	40	41	42	43	44	45	46

71	72	73	74	75	76	77	78
79	80	81	82	83	84	85	86
87	88	89	90	91	92		

2

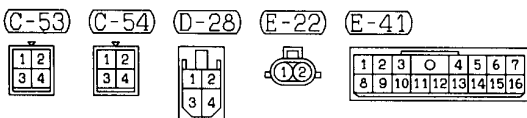
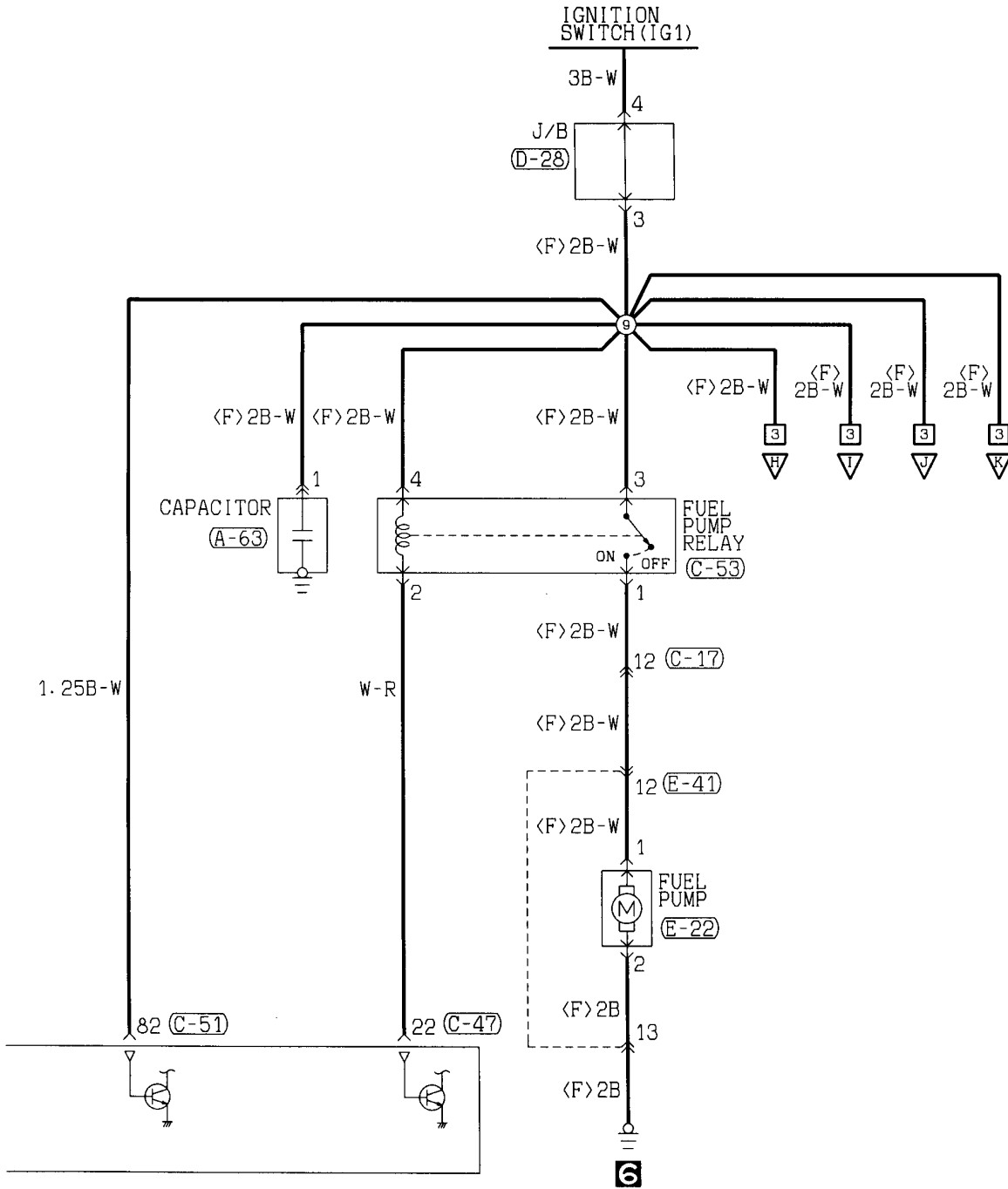

Wire colour code
 B :Black LG:Light green G :Green L :Blue W :White Y :Yellow SB:Sky blue
 BR:Brown O :Orange GR:Gray R :Red P :Pink V :Violet

ENGINE CONTROL SYSTEM <MPI-M/T> (CONTINUED)

3

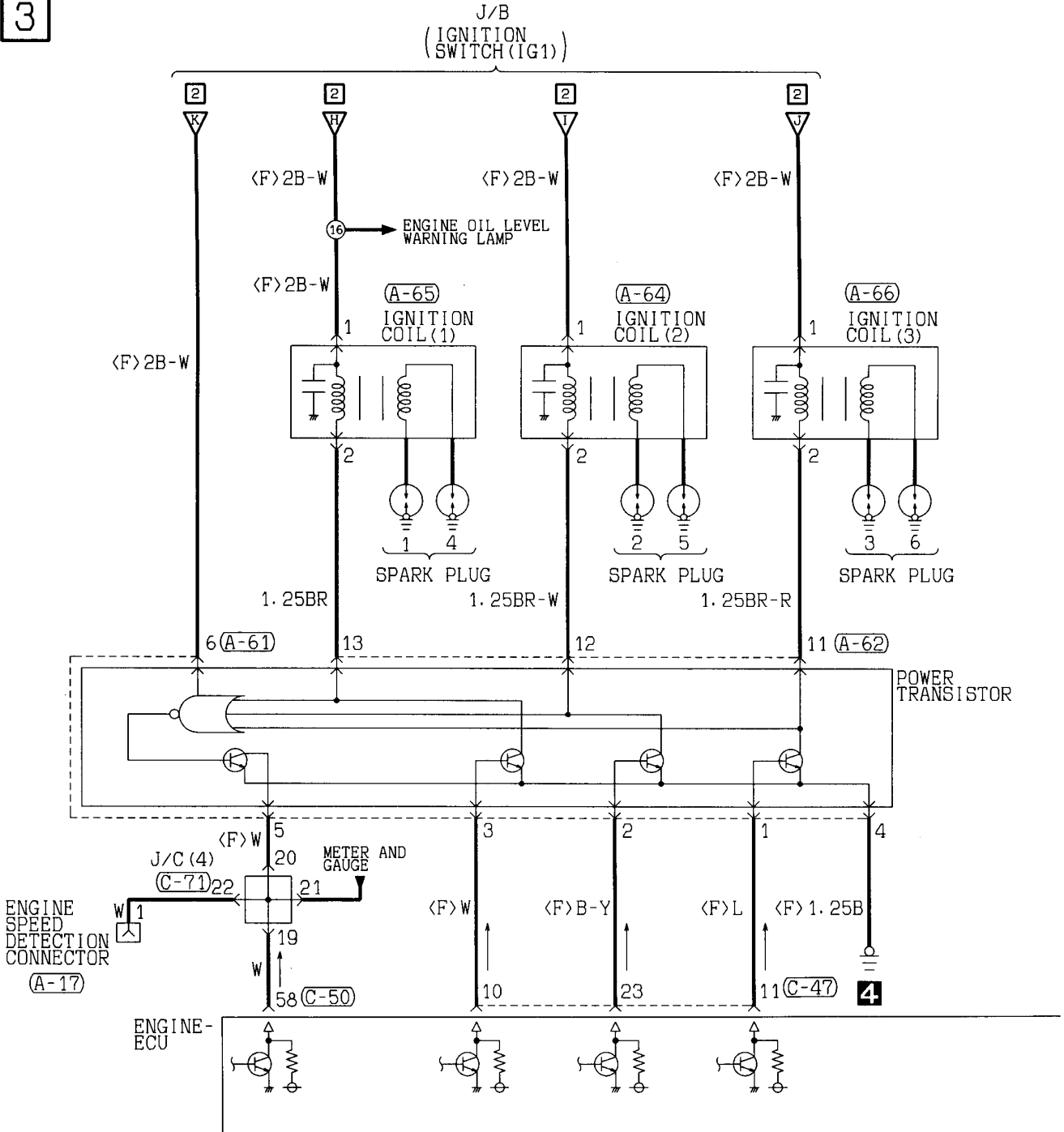

- (A-17) (A-25X) (A-61) (A-62) (A-64) (A-65) (A-66) (C-04) (C-17)
- | |
|---|
| 1 |
|---|

1	2
---	---

1	2	3	4	5	6
---	---	---	---	---	---

1	2
---	---

1	2
---	---

1	2
---	---

21	22	23	24	25	26	27	28	29	30	31	32
----	----	----	----	----	----	----	----	----	----	----	----

1	2	3	4	5	6	7	8	9	10		
11	12	13	14	15	16	17	18	19	20	21	22
- | | | | | | | |
|---|---|---|---|----|----|----|
| 1 | 2 | 3 | 4 | 5 | | |
| 6 | 7 | 8 | 9 | 10 | 11 | 12 |

1	2	3	4	5	6	7		
8	9	10	11	12	13	14	15	16

1	2	3
---	---	---

4

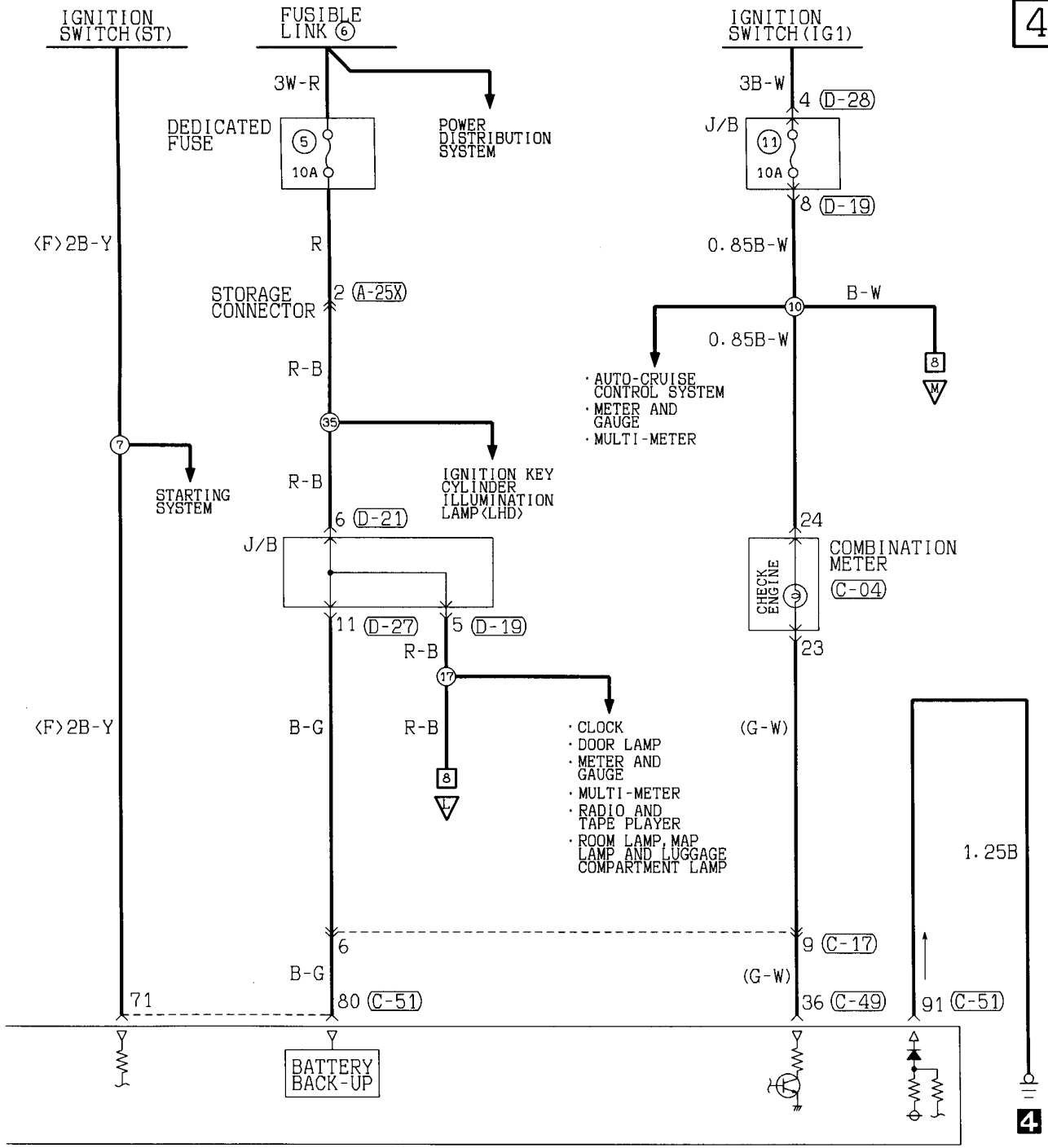

C-47	C-49	C-50	C-51	C-71	D-19
1 2 3 4 5 6 7 8 9 10 11 12 13 14 15 16 17 18 19 20 21 22 23 24 25 26	31 32 33 34 35 36 37 38 39 40 41 42 43 44 45 46	51 52 53 54 55 56 57 58 59 60 61 62	71 72 73 74 75 76 77 78 79 80 81 82 83 84 85 86 87 88 89 90 91 92	1 2 3 4 5 6 7 8 9 10 11 12 13 14 15 16 17 18 19 20 21 22 23 24 25 26 27 28 29 30 31 32 33	1 2 3 4 5 6 7 8 9 10 11 12 13 14 15 16

Wire colour code
 B : Black LG: Light green G : Green L : Blue W : White Y : Yellow SB: Sky blue
 BR: Brown O : Orange GR: Gray R : Red P : Pink V : Violet

ENGINE CONTROL SYSTEM <MPI-M/T> (CONTINUED)

5

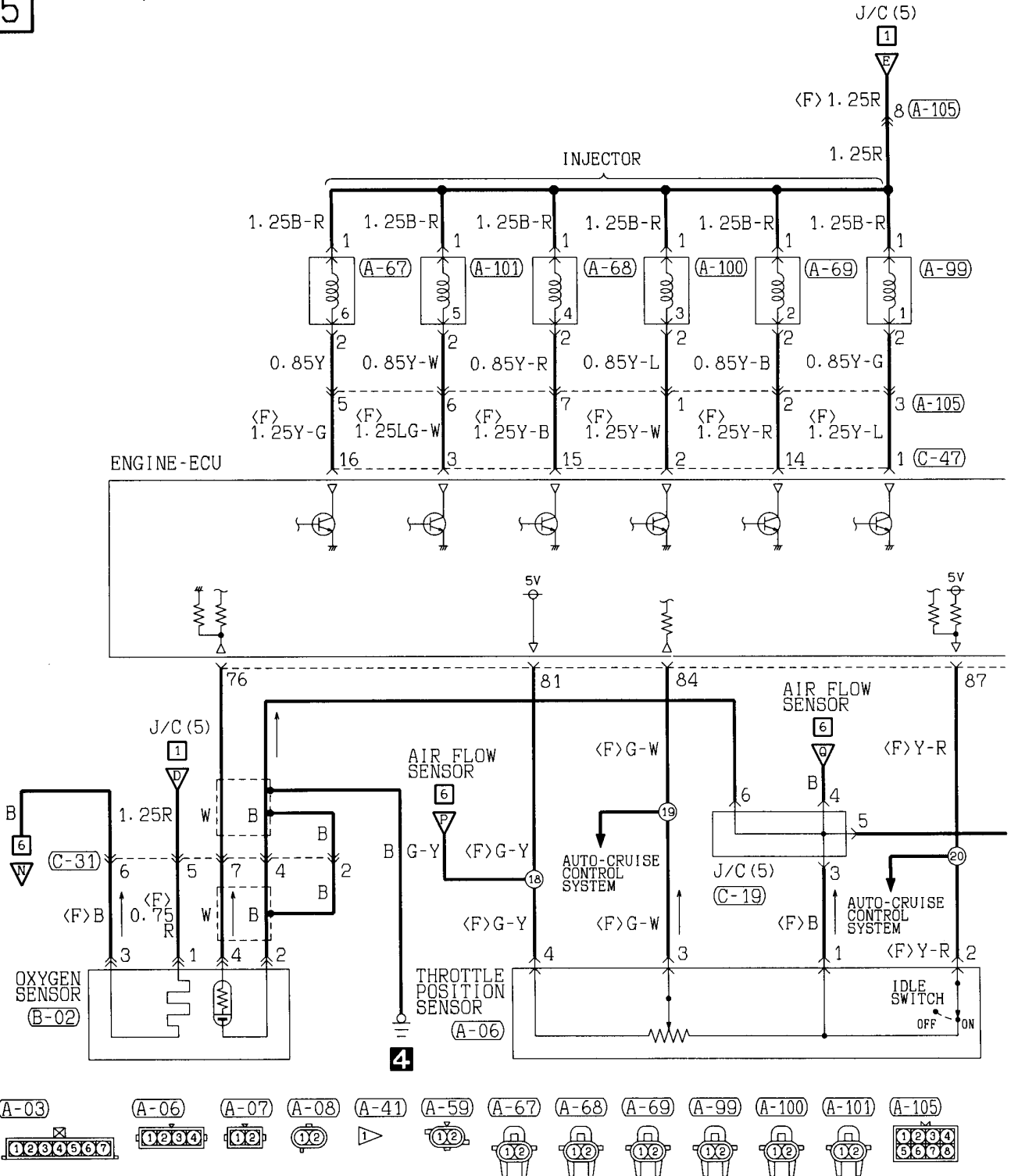

6

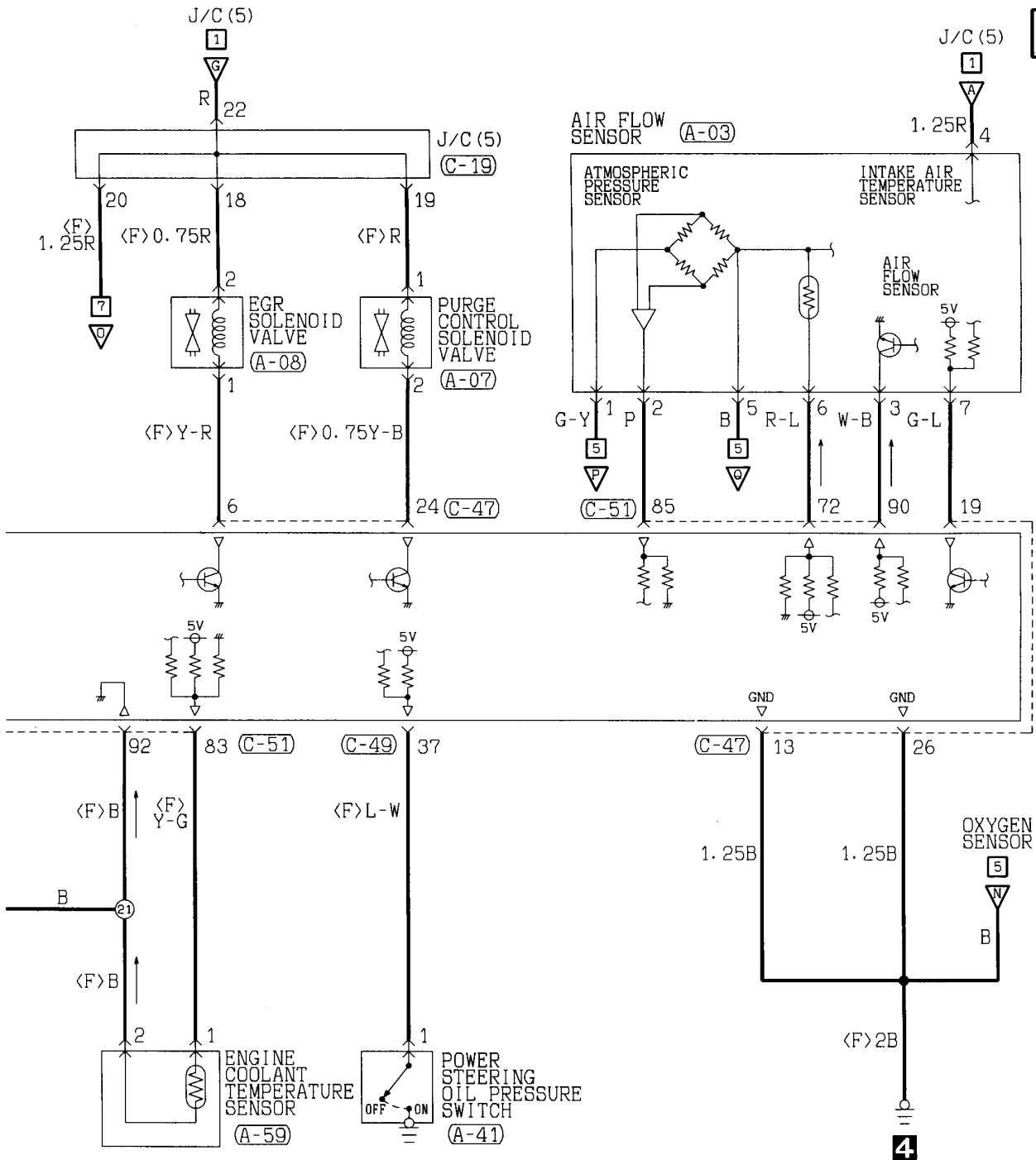

(B-02)

1	2
3	4

(C-19)

1	2	3	4	5	6	7	8	9	10	11
12	13	14	15	16	17	18	19	20	21	22
23	24	25	26	27	28	29	30	31	32	33

(C-31)

1	2			
3	4	5	6	7

(C-47)

1	2	3	4	5	6	7	8	9	10	11	12	13
14	15	16	17	18	19	20	21	22	23	24	25	26

(C-49)

31	32	33	34	35	36	37	38
39	40	41	42	43	44	45	46

(C-51)

71	72	73	74	75	76	77	78	79	80	81
82	83	84	85	86	87	88	89	90	91	92

Wire colour code
 B :Black LG:Light green G :Green L :Blue W :White Y :Yellow SB:Sky blue
 BR:Brown O :Orange GR:Gray R :Red P :Pink V :Violet

ENGINE CONTROL SYSTEM <MPI-M/T> (CONTINUED)

7

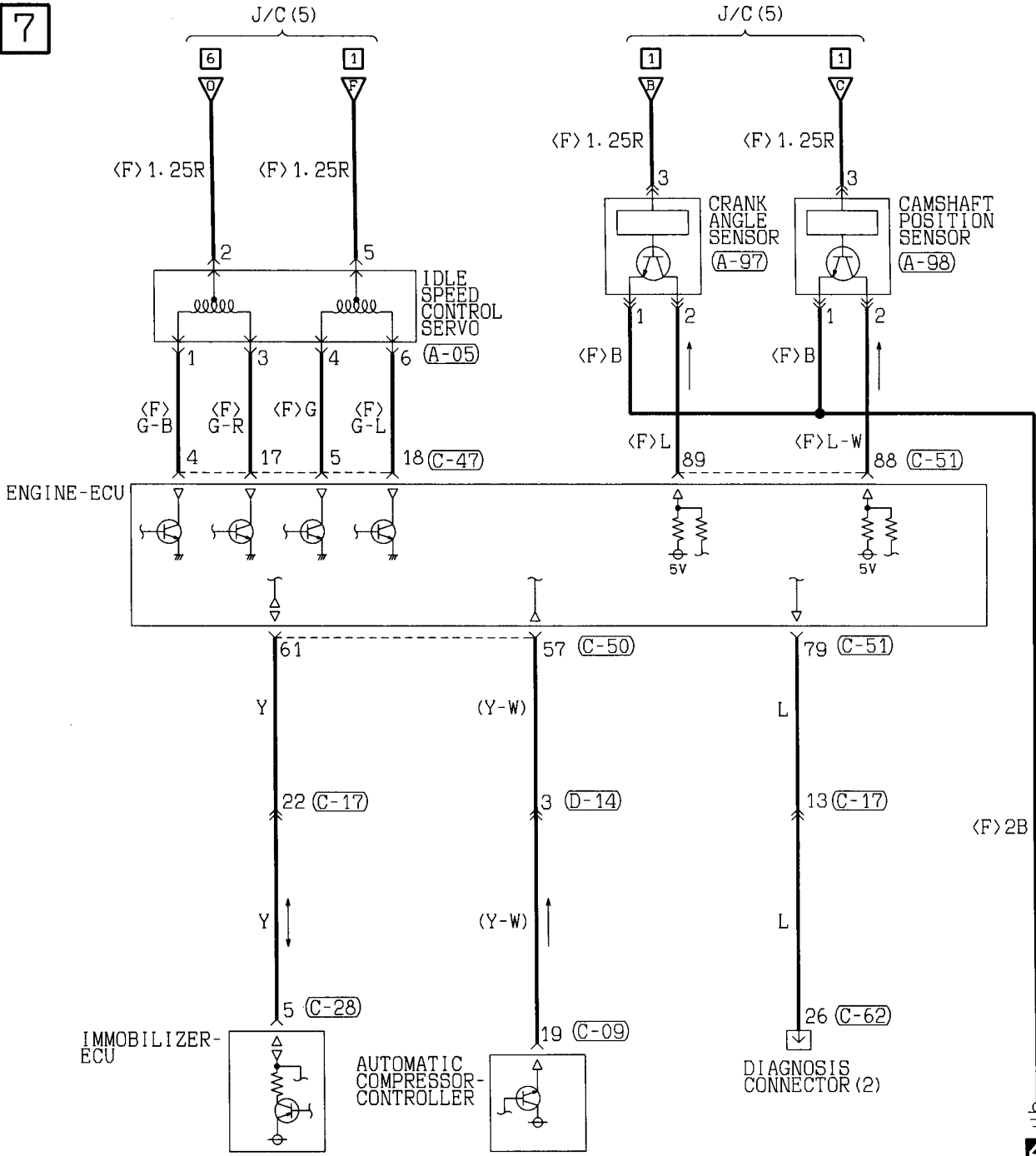

4

(A-05)	(A-97)	(A-98)	(B-03)	(C-09)	(C-11)	(C-12)	(C-17)
(C-62) FRONT SIDE	(C-63) FRONT SIDE	(D-14)					

8

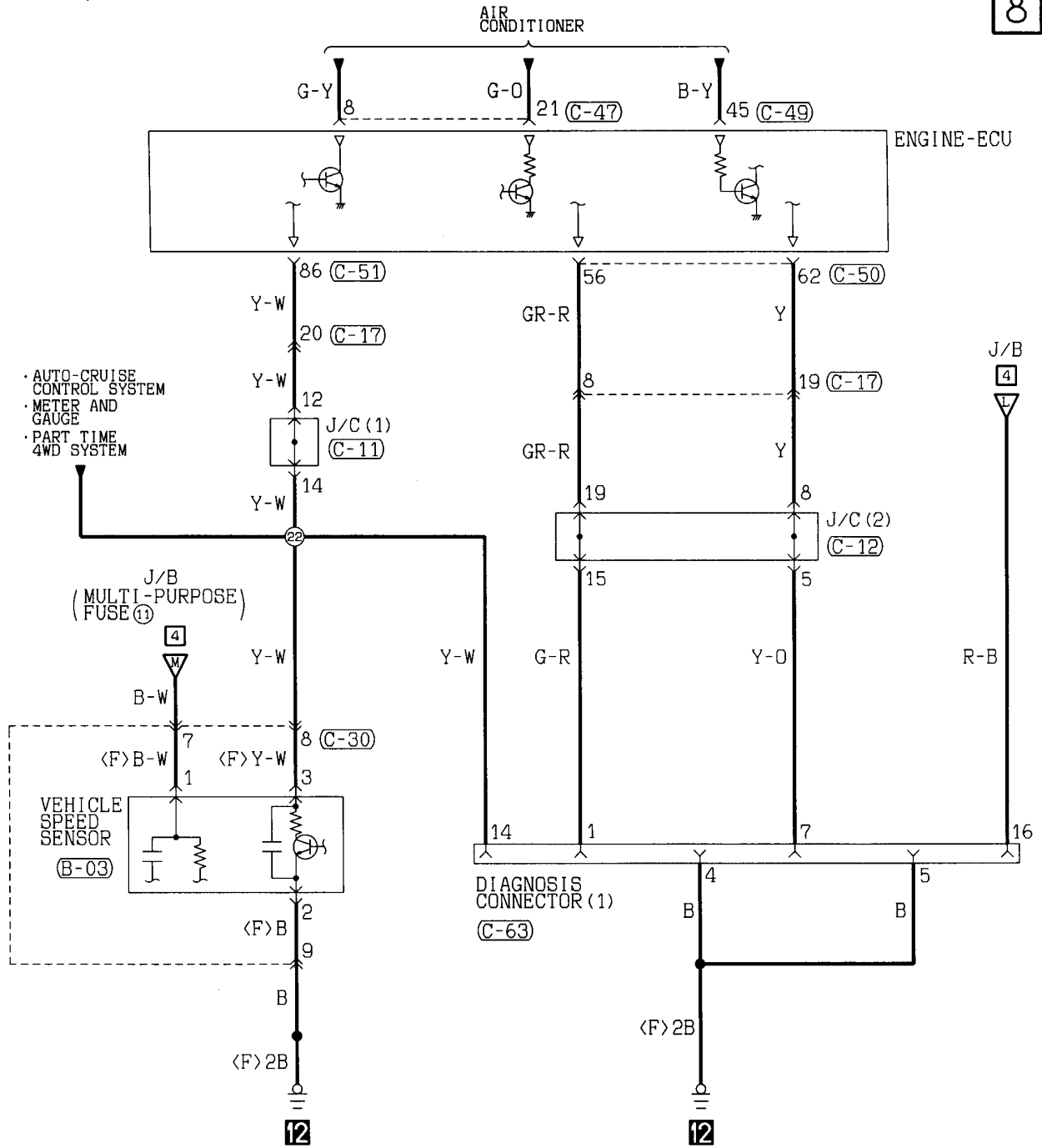

C-28

1	2	3	4	5
6	7	8	9	10
11	12			

C-30

1	2	3	4
5	6	7	8
9			

C-47

1	2	3	4	5	6	7	8	9	10	11	12	13
14	15	16	17	18	19	20	21	22	23	24	25	26

C-49

31	32	33	34	35	36	37	38
39	40	41	42	43	44	45	46

C-50

51	52	53	54	55	56
57	58	59	60	61	62

C-51

71	72	73	74	75	76	77	78	79	80	81
82	83	84	85	86	87	88	89	90	91	92

Wire colour code
 B :Black LG:Light green G :Green L :Blue W :White Y :Yellow SB:Sky blue
 BR:Brown O :Orange GR:Gray R :Red P :Pink V :Violet

ENGINE CONTROL SYSTEM
MPI-A/T

1

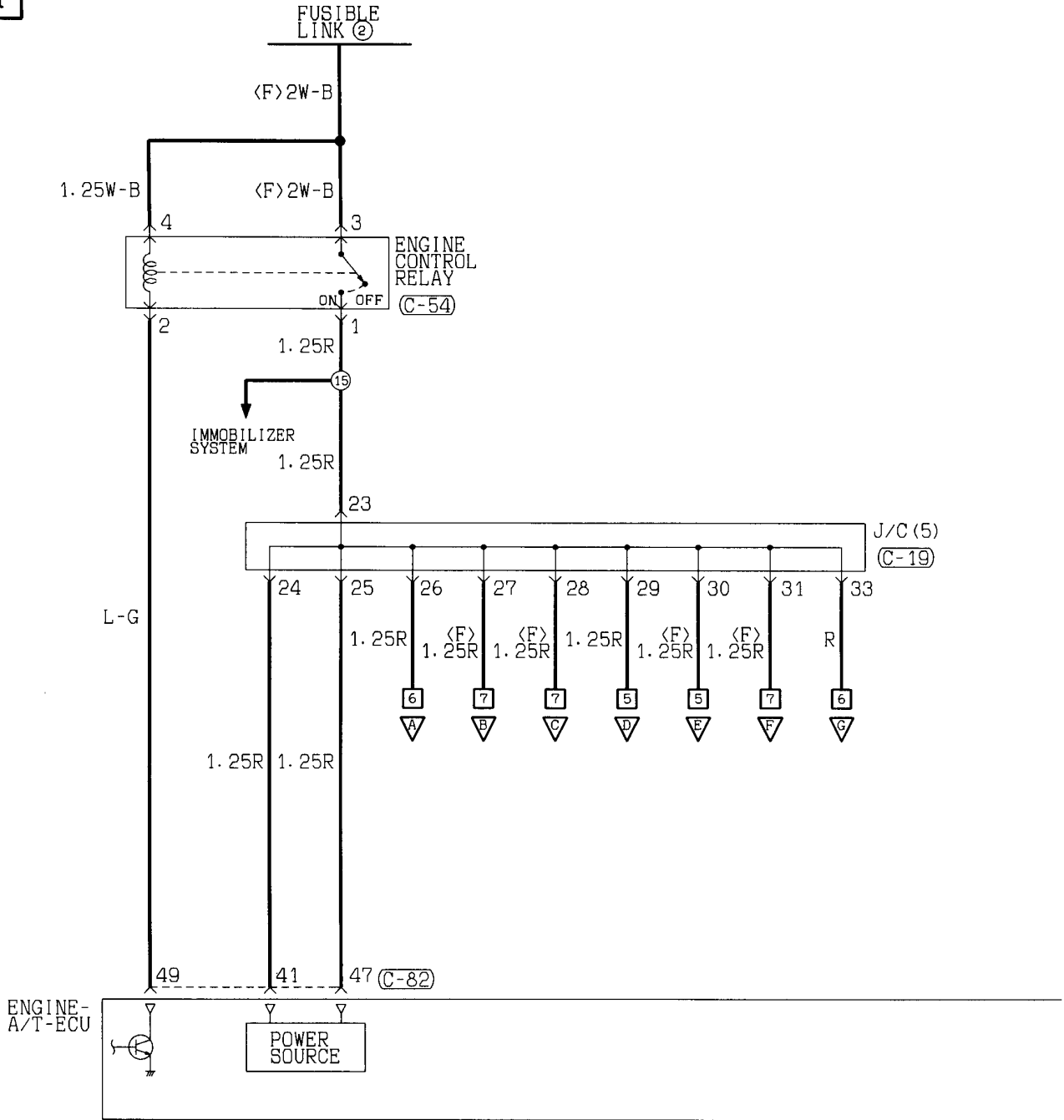

(A-63)



(C-17)

1	2	3	4	5	6	7	8	9	10
11	12	13	14	15	16	17	18	19	20
21	22								

(C-19)

1	2	3	4	5	6	7	8	9	10
11	12	13	14	15	16	17	18	19	20
21	22	23	24	25	26	27	28	29	30
31	32	33							

(C-53)

1	2
3	4

(C-54)

1	2
3	4

(C-81)

1	2	3	4		5	6	7	8
9	10	11	12	13	14	15	16	17
18	19	20	21	22	23			
24	25	26	27	28	29	30	31	32
33	34	35						

2

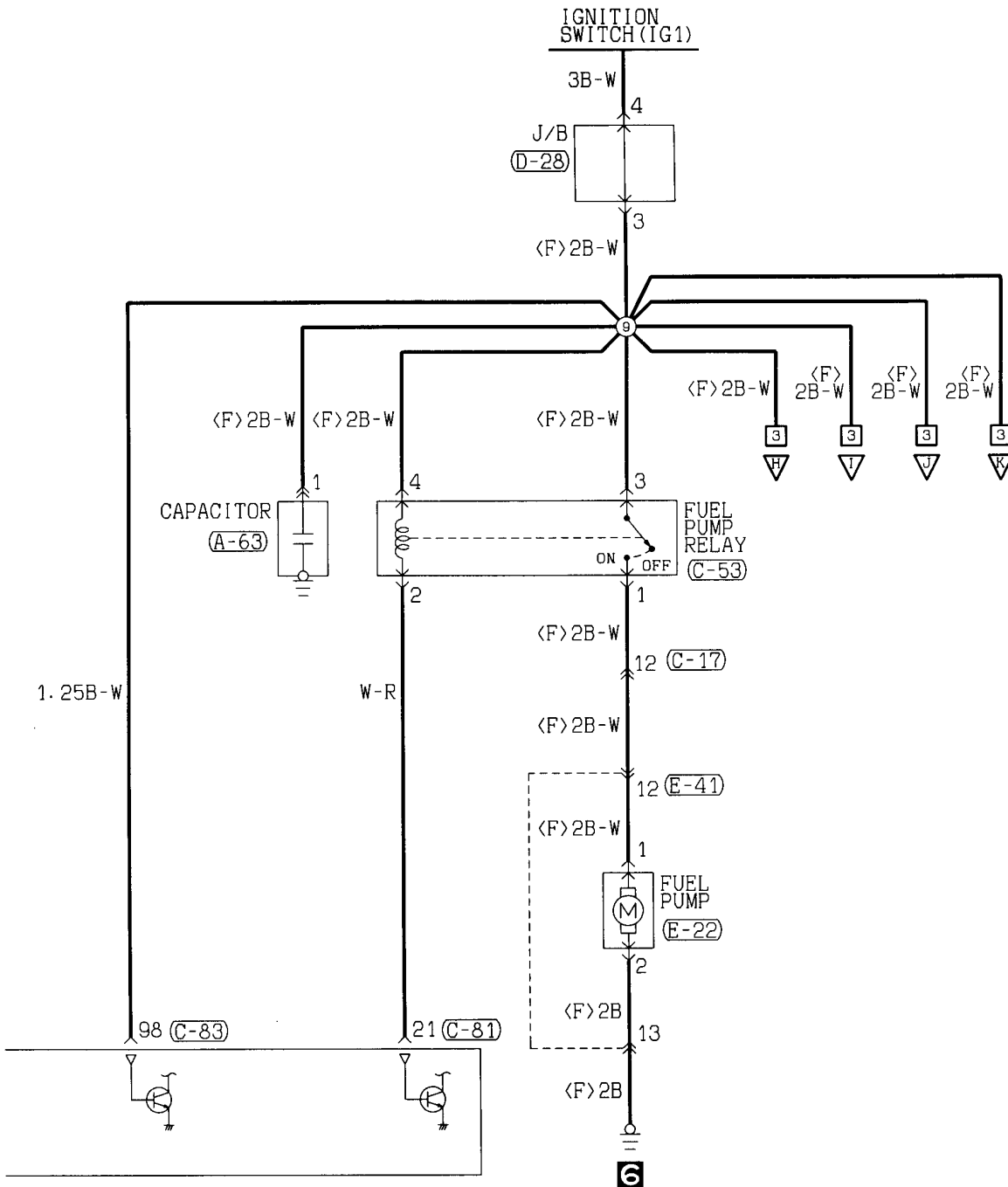

(C-82)

41	42	43		44	45	46
47	48	49	50	51	52	53
54	55	56	57	58	59	60
61	62	63	64	65	66	

(C-83)

71	72	73	74		75	76	77
78	79	80	81	82	83	84	85
86	87	88	89	90	91	92	93
94	95	96	97	98			

(D-28)

1	2
3	4

(E-22)



(E-41)

1	2	3	4	5	6	7
8	9	10	11	12	13	14
15	16					

Wire colour code
 B : Black LG : Light green G : Green L : Blue W : White Y : Yellow SB : Sky blue
 BR : Brown O : Orange GR : Gray R : Red P : Pink V : Violet

ENGINE CONTROL SYSTEM <MPI-A/T> (CONTINUED)

3

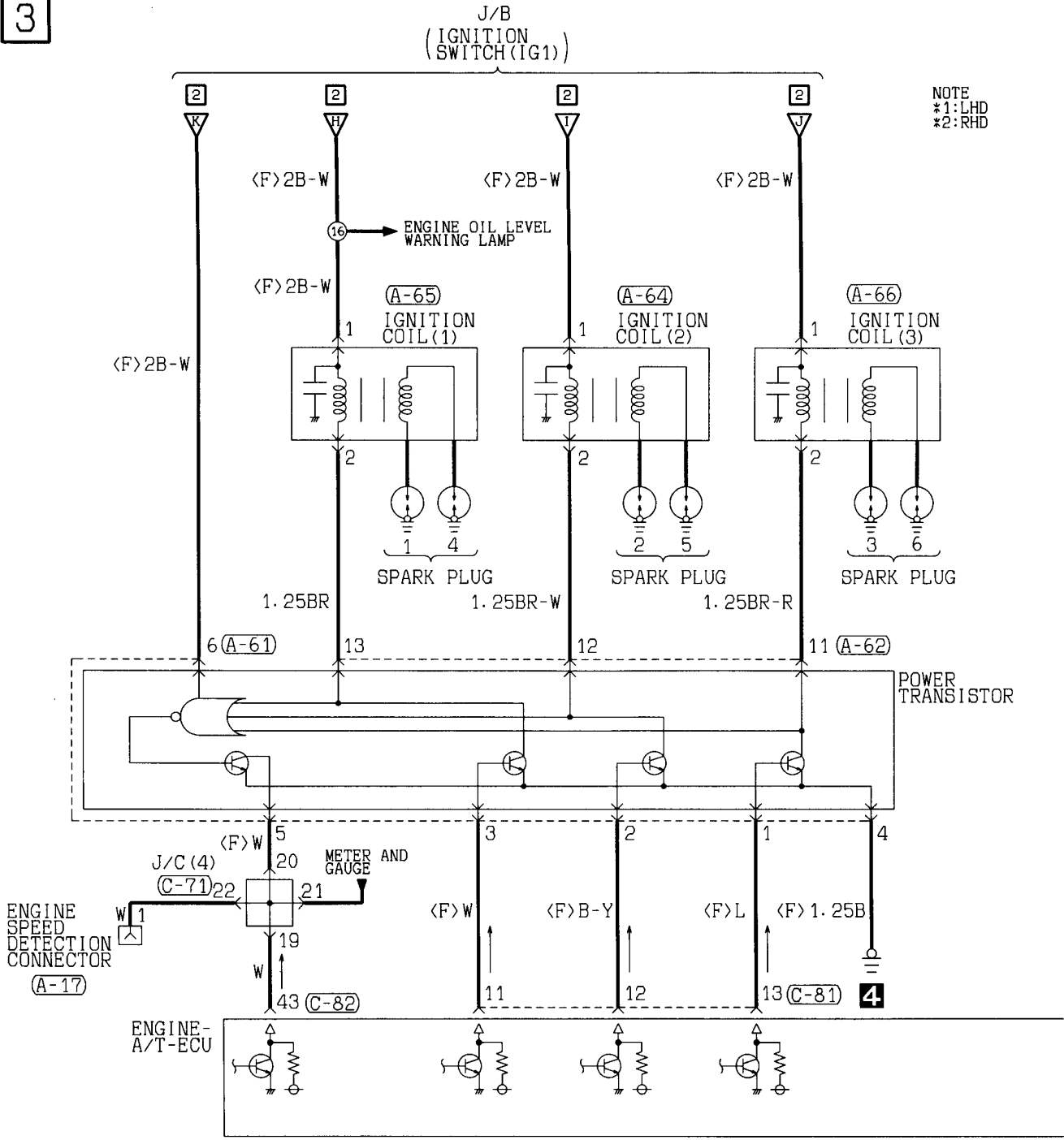

NOTE
*1:LHD
*2:RHD

A-17	A-25X	A-61	A-62	A-64	A-65	A-66	B-10	C-04
1	12	12 3 4 5 6	12 3	12	12	12	1 2 3 4 5 6 7 8 9 10	21 22 23 24 25 26 27 28 29 30 31 32
C-82	C-90	D-19	D-21	D-27	D-28			
41 42 43 47 48 49 50 51 52 53 54 55 56 57 58 59 60 61 62 63 64 65 66	1 2 3 4 5 6 7 8 9 10 11 12 13 14 15 16 17 18 19 20	1 2 3 4 5 6 7 8 9 10 11 12 13 14 15 16	1 2 3 4 5 6 7 8 9 10 11 12	1 2 3 4 5 6 7 8 9 10 11 12 13 14 15 16	1 2 3 4			

4

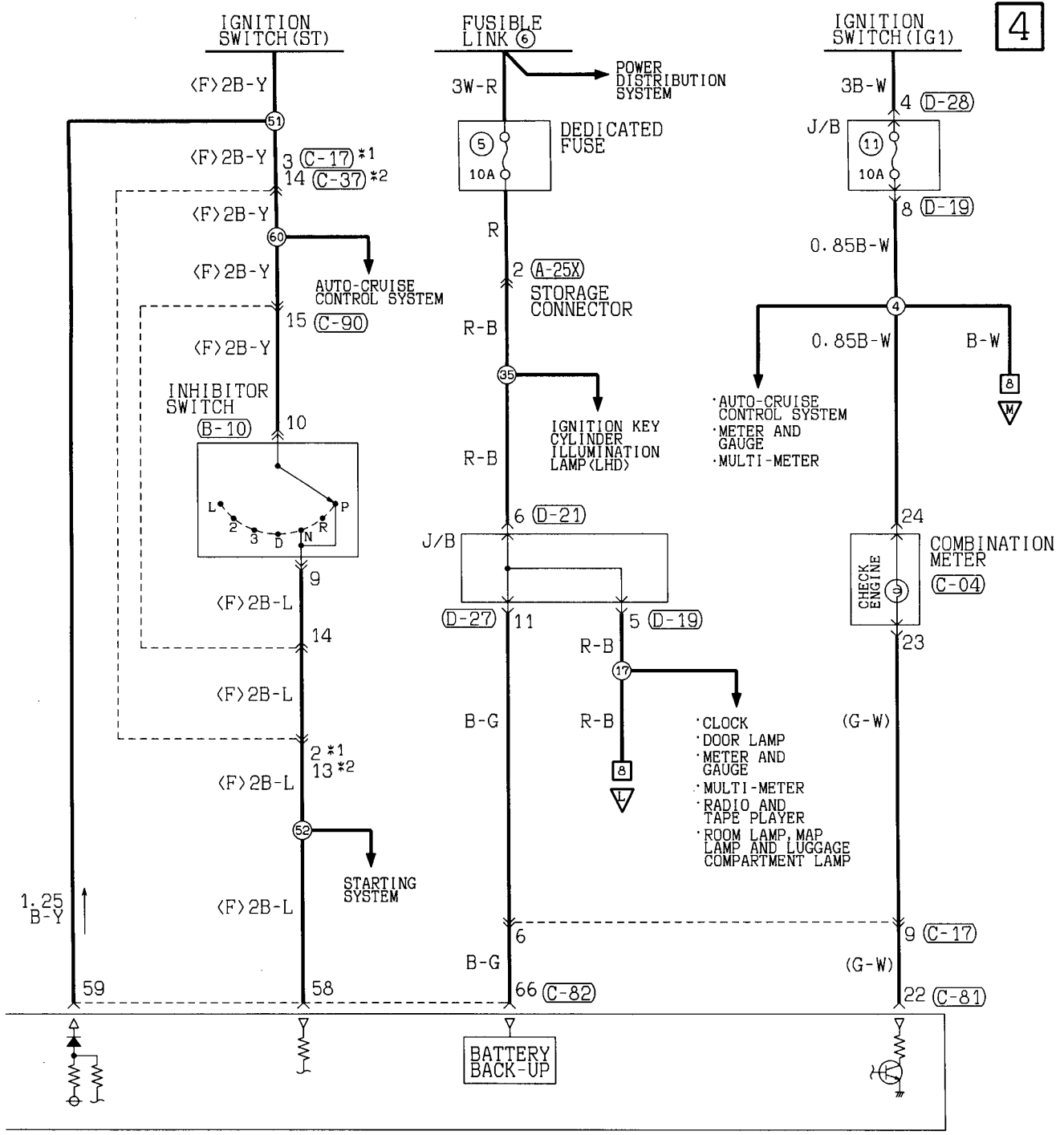

(C-17)

1	2	3	4	5	6	7	8	9	10
11	12	13	14	15	16	17	18	19	20
21	22								

(C-37)

1	2	3	4	5	6	7	8	9	10
11	12	13	14	15	16	17	18	19	20
21	22								

(C-71)

1	2	3	4	5	6	7	8	9	10	11
12	13	14	15	16	17	18	19	20	21	22
23	24	25	26	27	28	29	30	31	32	33

(C-81)

1	2	3	4	5	6	7	8
9	10	11	12	13	14	15	16
17	18	19	20	21	22	23	24
25	26	27	28	29	30	31	32
33	34	35					

Wire colour code
 B : Black LG: Light green G : Green L : Blue W : White Y : Yellow SB: Sky blue
 BR: Brown O : Orange GR: Gray R : Red P : Pink V : Violet

ENGINE CONTROL SYSTEM <MPI-A/T> (CONTINUED)

5

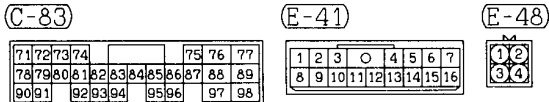
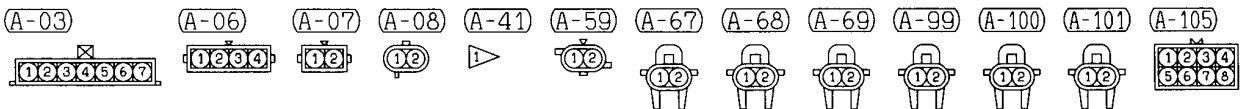
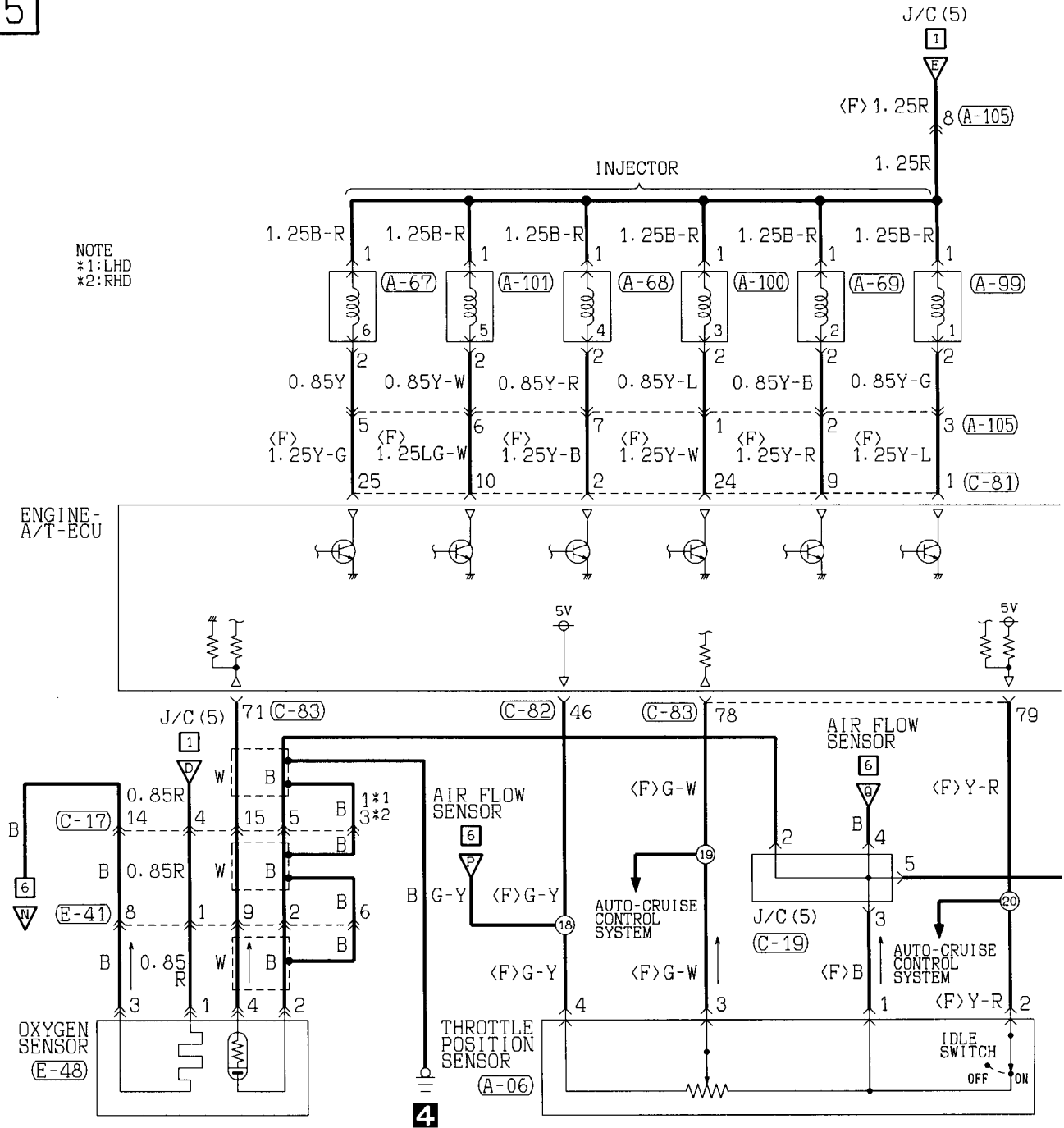

6

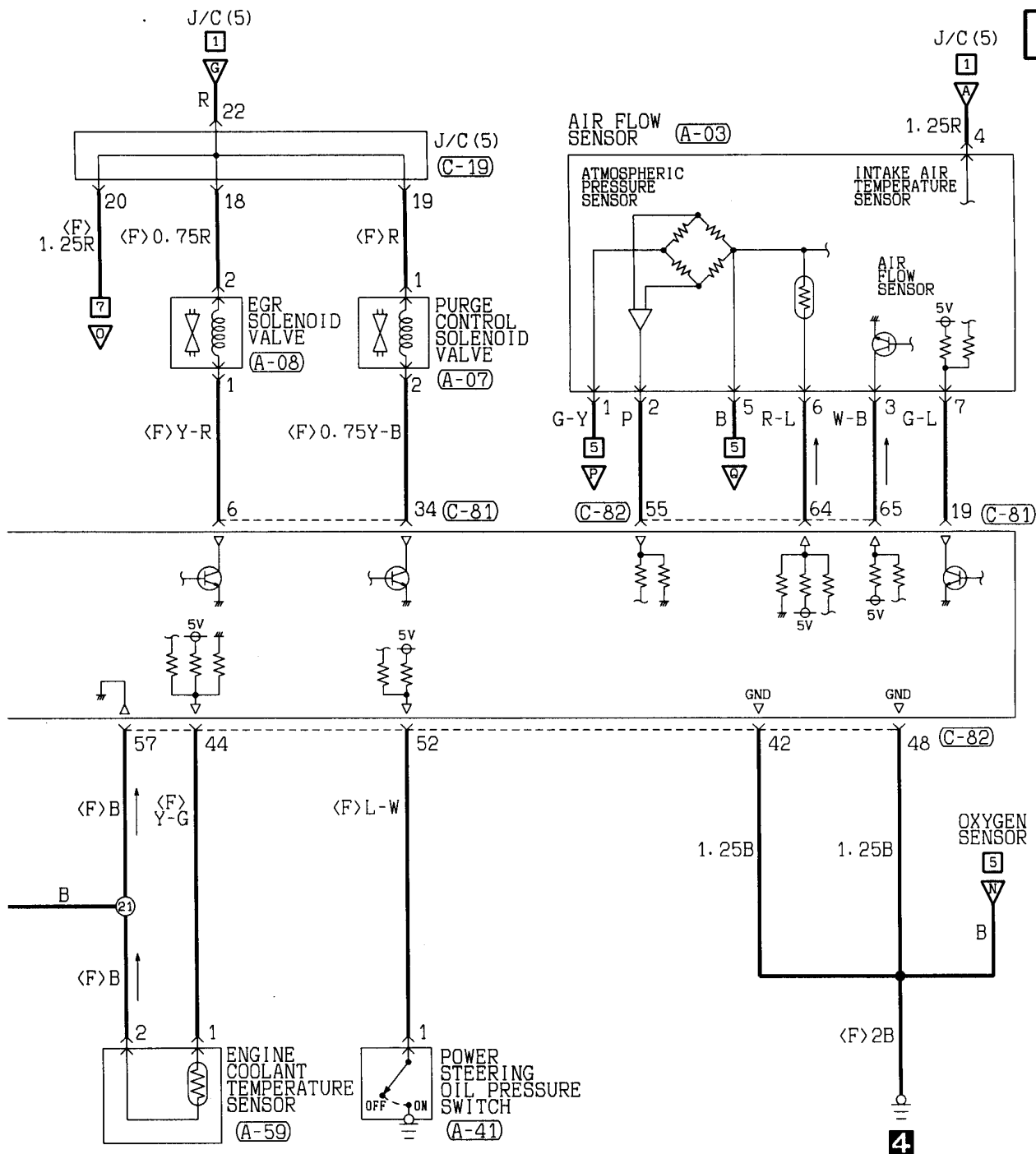

(C-17)

1	2	3	4	5	6	7	8	9	10		
11	12	13	14	15	16	17	18	19	20	21	22
23	24	25	26	27	28	29	30	31	32	33	

(C-19)

1	2	3	4	5	6	7	8	9	10	11
12	13	14	15	16	17	18	19	20	21	22
23	24	25	26	27	28	29	30	31	32	33

(C-81)

1	2	3	4	5	6	7	8							
9	10	11	12	13	14	15	16	17	18	19	20	21	22	23
24	25	26	27	28	29	30	31	32	33	34	35			

(C-82)

41	42	43	44	45	46					
47	48	49	50	51	52	53	54	55	56	57
58	59	60	61	62	63	64	65	66		

Wire colour code
 B :Black LG:Light green G :Green L :Blue W :White Y :Yellow SB:Sky blue
 BR:Brown O :Orange GR:Gray R :Red P :Pink V :Violet

ENGINE CONTROL SYSTEM <MPI-A/T> (CONTINUED)

7

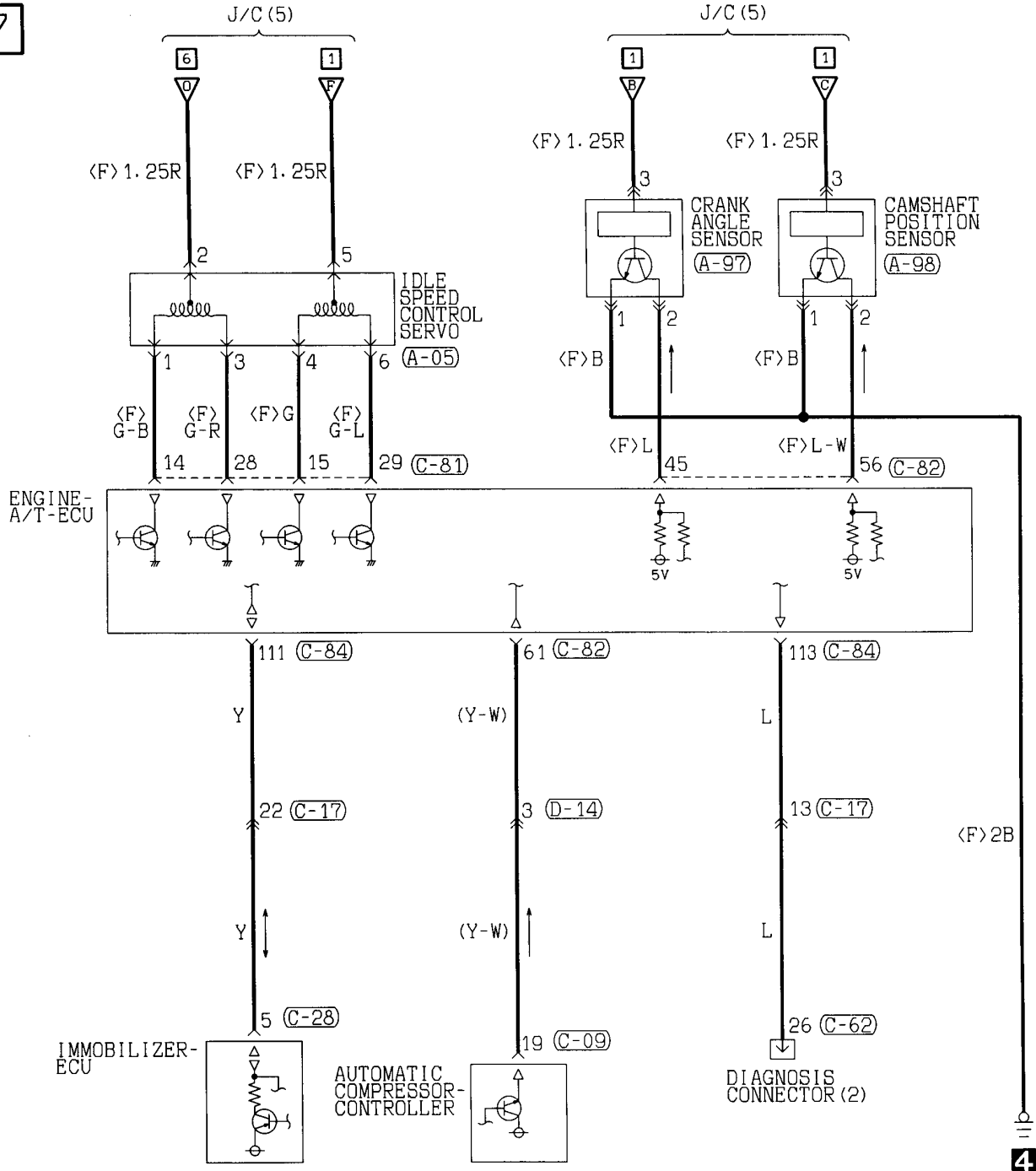

(A-05)



(A-97)



(A-98)



(B-03)



(C-09)

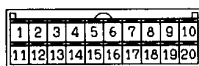

(C-11)

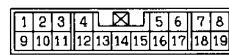

(C-12)

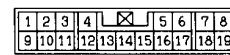

(C-17)

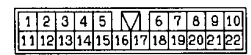

(C-83)

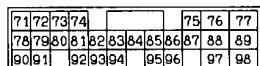

(C-84)

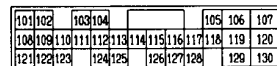

(D-14)

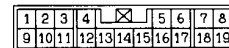

8

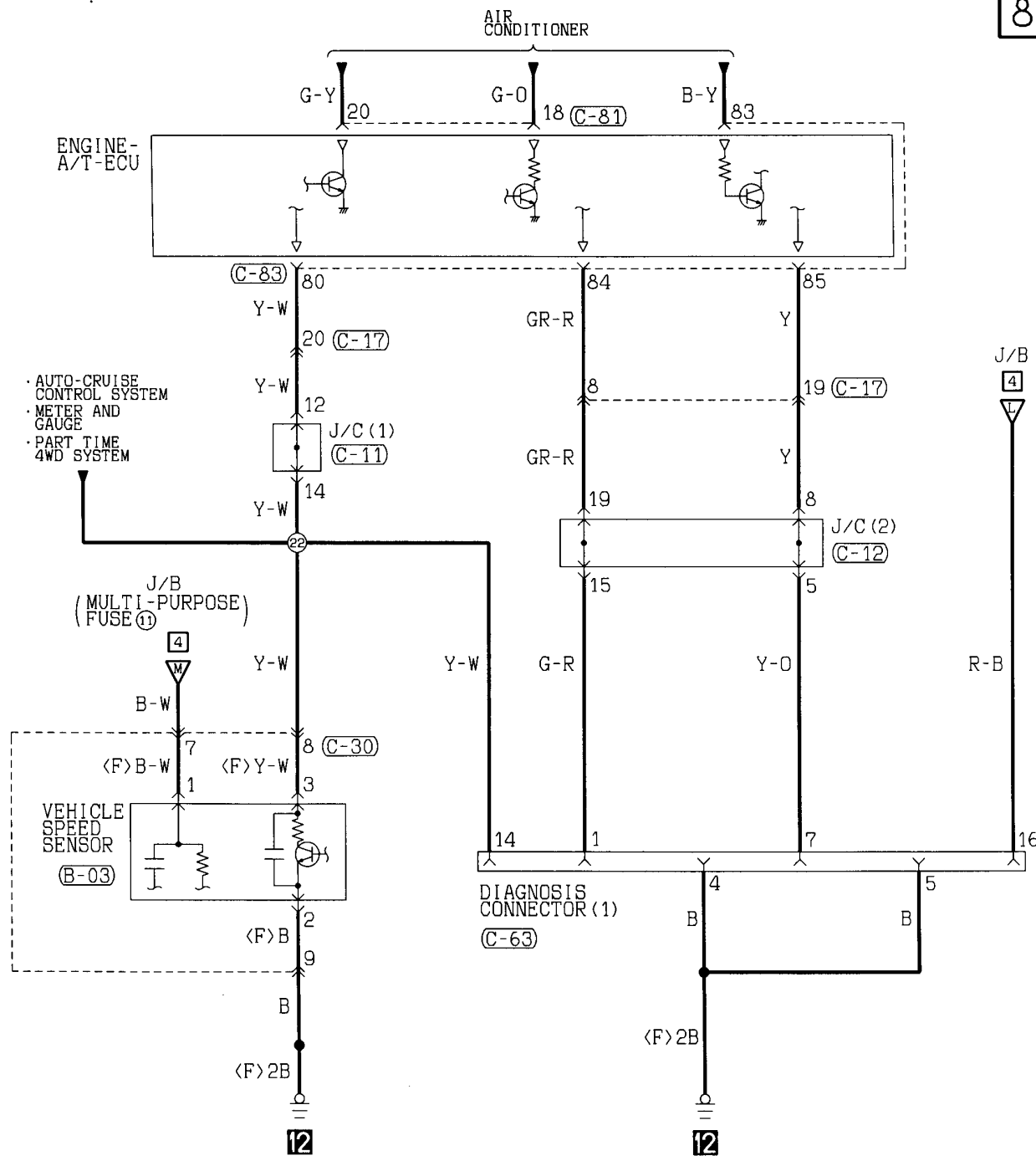

(C-28)

1	2	3	4	5
6	7	8	9	10
11	12			

(C-30)

1	2	3
4	5	6
7	8	9

(C-62) FRONT SIDE

25	24	23	22	21
32	31	30	29	28
27	26			

(C-63) FRONT SIDE

1	2	3	4	5	6	7	8
9	10	11	12	13	14	15	16

(C-81)

1	2	3	4	5	6	7	8
9	10	11	12	13	14	15	16
17	18	19	20	21	22	23	24
25	26	27	28	29	30	31	32
33	34	35					

(C-82)

41	42	43	44	45	46
47	48	49	50	51	52
53	54	55	56	57	58
59	60	61	62	63	64
65	66				

Wire colour code
 B :Black LG:Light green G :Green L :Blue W :White Y :Yellow SB:Sky blue
 BR:Brown O :Orange GR:Gray R :Red P :Pink V :Violet

ENGINE CONTROL SYSTEM

Diesel

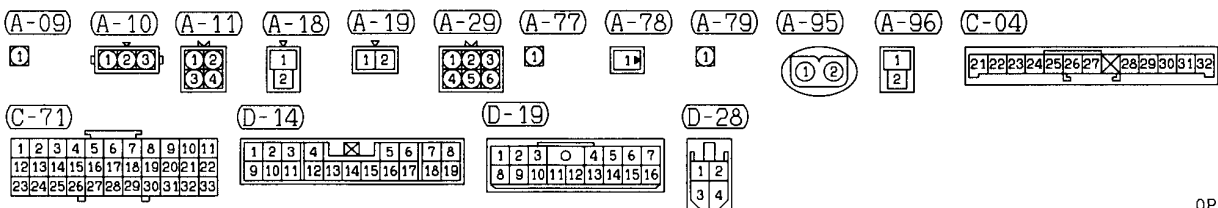
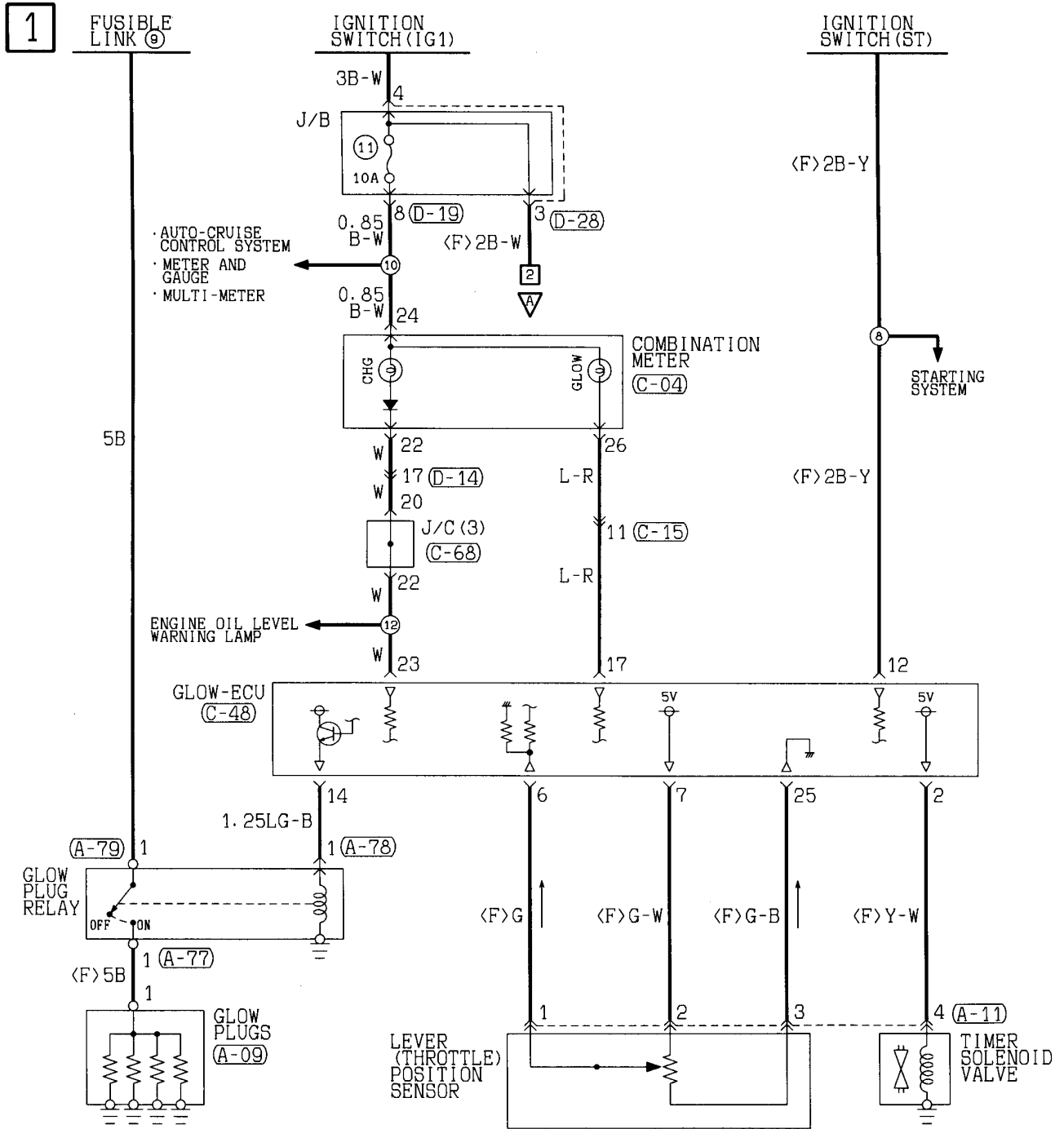

2

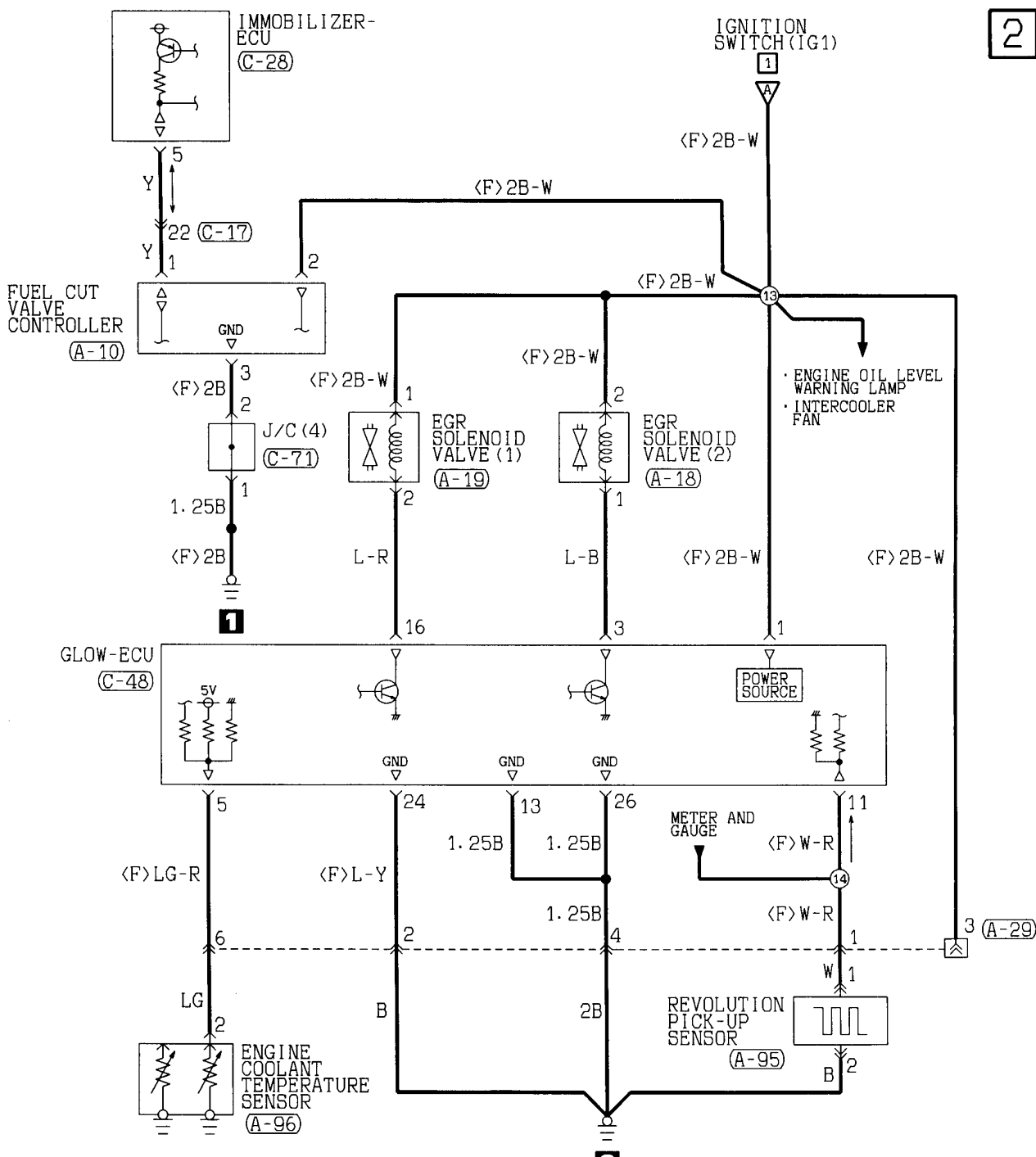

(C-15)

1	2	3	0	4	5
6	7	8	9	10	11
12	13	14	15	16	17

(C-17)

1	2	3	4	5	M	6	7	8	9	10
11	12	13	14	15	16	17	18	19	20	21
22										

(C-28)

1	2	3	4	5
6	7	8	9	10
11	12			

(C-48)

1	2	3	4	5	6	7	8	9	10	11	12	13
14	15	16	17	18	19	20	21	22	23	24	25	26

(C-68)

1	2	3	4	5	6	7	8	9	10	11
12	13	14	15	16	17	18	19	20	21	22
23	24	25	26	27	28	29	30	31	32	33

Wire colour code
 B :Black LG:Light green G :Green L :Blue W :White Y :Yellow SB:Sky blue
 BR:Brown O :Orange GR:Gray R :Red P :Pink V :Violet

INVECS-II 4A/T

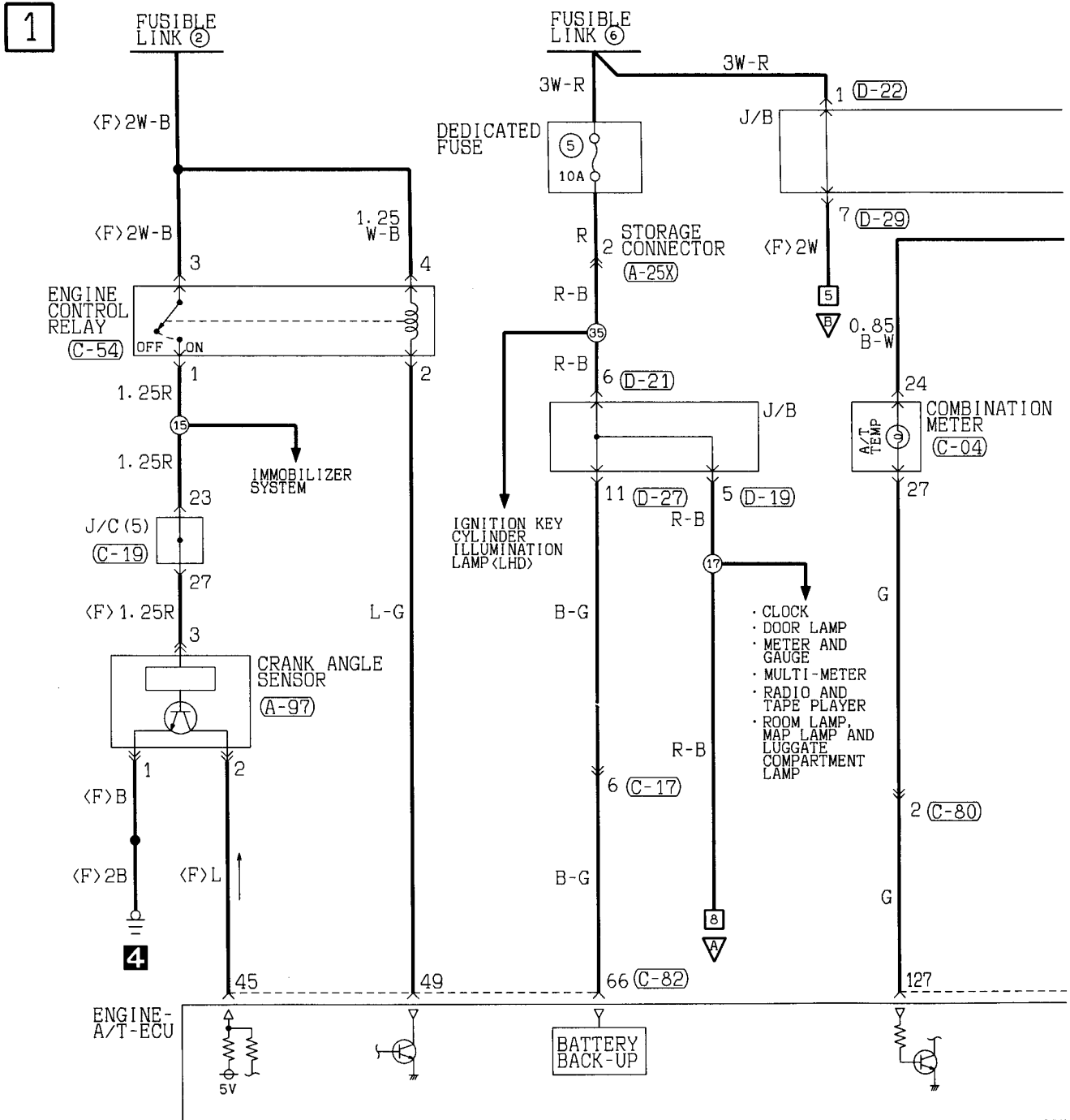

(A-25X) (A-97) (B-08) (B-12) (C-04)

(C-11)

(C-17)

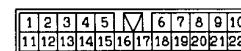
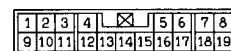
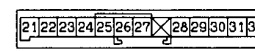

(C-84)

(C-88)

(C-90)

(C-91)

(D-19)

(D-21)

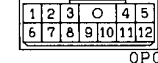
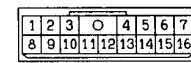
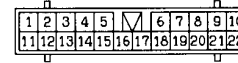
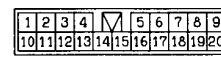
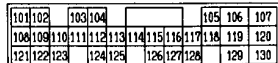

2

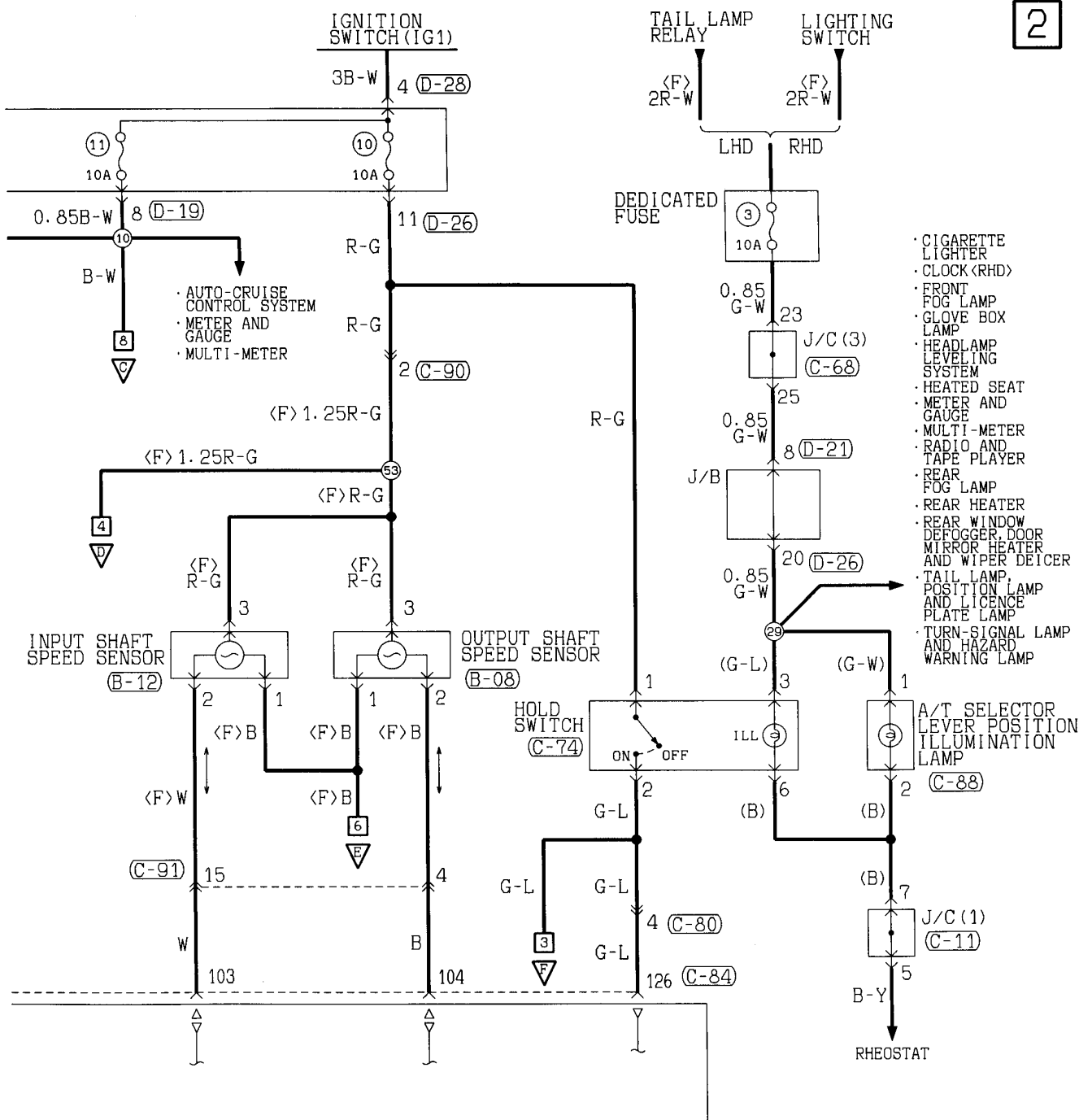

(C-19)

1	2	3	4	5	6	7	8	9	10	11
12	13	14	15	16	17	18	19	20	21	22
23	24	25	26	27	28	29	30	31	32	33

(C-54)

1	2
3	4

(C-68)

1	2	3	4	5	6	7	8	9	10	11
12	13	14	15	16	17	18	19	20	21	22
23	24	25	26	27	28	29	30	31	32	33

(C-74)

1	2
3	4
5	6

(C-80)

1	2	3
4	5	6
7	8	

(C-82)

41	42	43	44	45	46
47	48	49	50	51	52
53	54	55	56	57	58
59	60	61	62	63	64
65	66				

(D-22)

1	2
3	4

(C-26)

1	2	3	4	5	6	7	8	9
10	11	12	13	14	15	16	17	18
19	20	21	22					

(D-28)

1	2
3	4

(D-29)

1	2	3
4	5	6
7	8	

Wire colour code
 B : Black LG : Light green G : Green L : Blue
 BR : Brown O : Orange GR : Gray R : Red
 W : White SB : Sky blue P : Pink Y : Yellow
 V : Violet

OP07E02AB

INVECS-II 4A/T (CONTINUED)

3

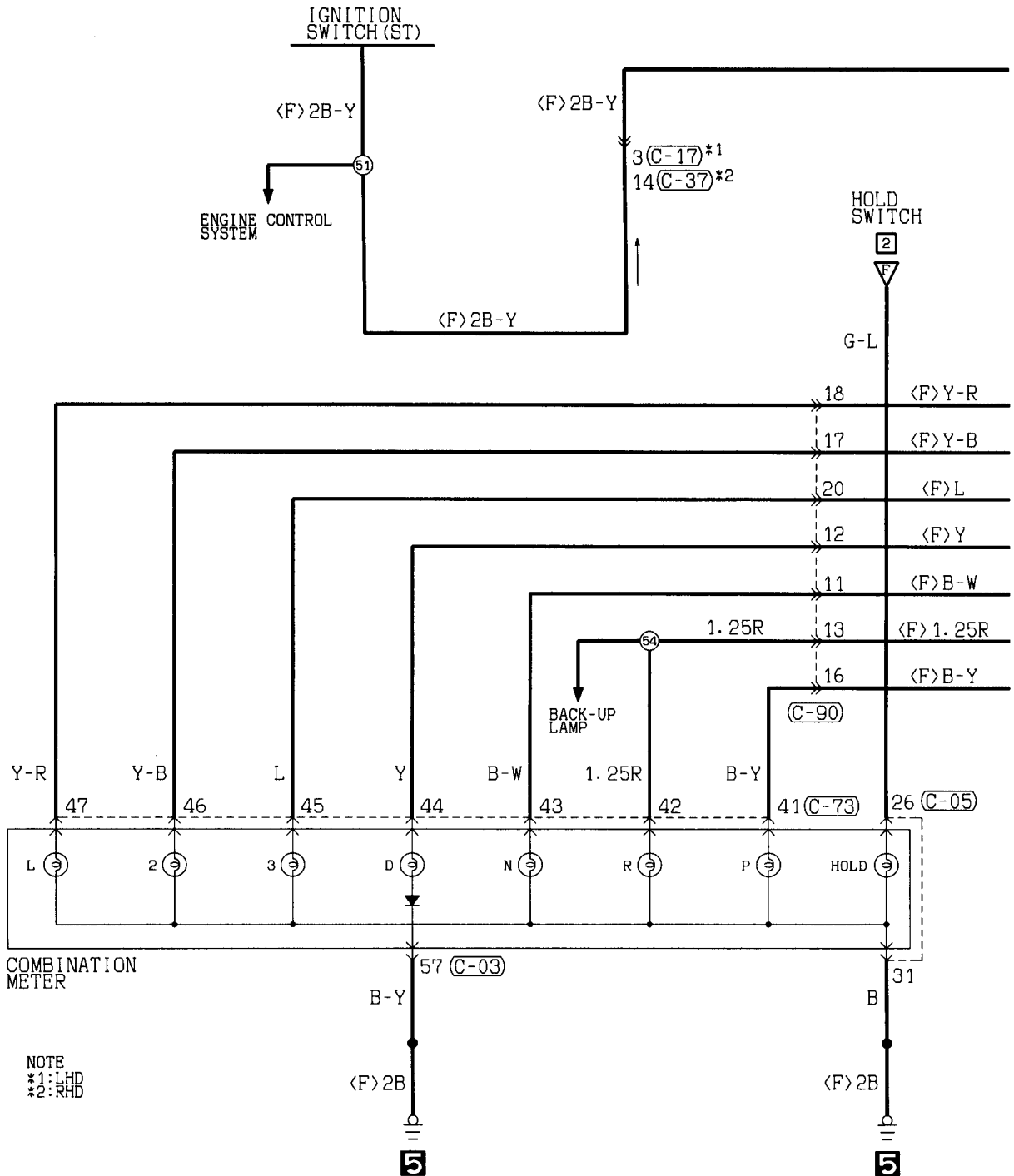

NOTE
*1: LHD
*2: RHD

(B-10)

1	2	3	4	5
6	7	8	9	10

(C-03)

51	52	53	54	55	X	56	57	58	59	60	61	62
----	----	----	----	----	---	----	----	----	----	----	----	----

(C-05)

21	22	23	24	25	26	27	X	28	29	30	31	32
----	----	----	----	----	----	----	---	----	----	----	----	----

(C-17)

1	2	3	4	5	N	6	7	8	9	10	
11	12	13	14	15	16	17	18	19	20	21	22

(C-37)

1	2	3	4	5	N	6	7	8	9	10	
11	12	13	14	15	16	17	18	19	20	21	22

4

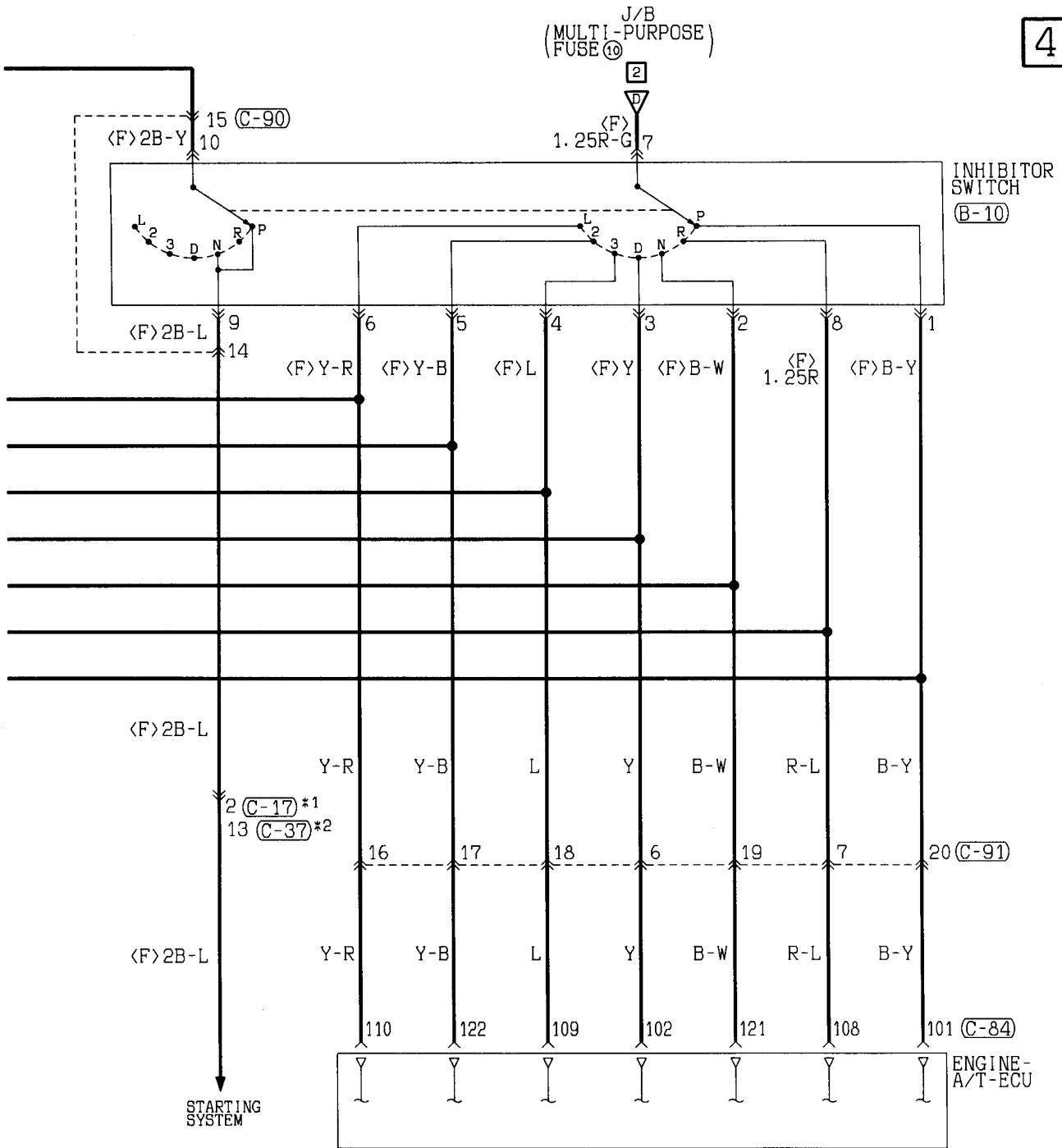

(C-73)

41	42	43	44	45	46	47	48	49	50

(C-84)

101	102	103	104	105	106	107
108	109	110	111	112	113	114
115	116	117	118	119	120	
121	122	123	124	125	126	127
128	129	130				

(C-90)

1	2	3	4	5	6	7	8	9
10	11	12	13	14	15	16	17	18
19	20							

(C-91)

1	2	3	4	5	6	7	8	9	10
11	12	13	14	15	16	17	18	19	20
21	22								

Wire colour code
 B:Black LG:Light green G:Green L:Blue W:White Y:Yellow SB:Sky blue
 BR:Brown O:Orange GR:Gray R:Red P:Pink V:Violet

INVECS-II 4A/T (CONTINUED)

5

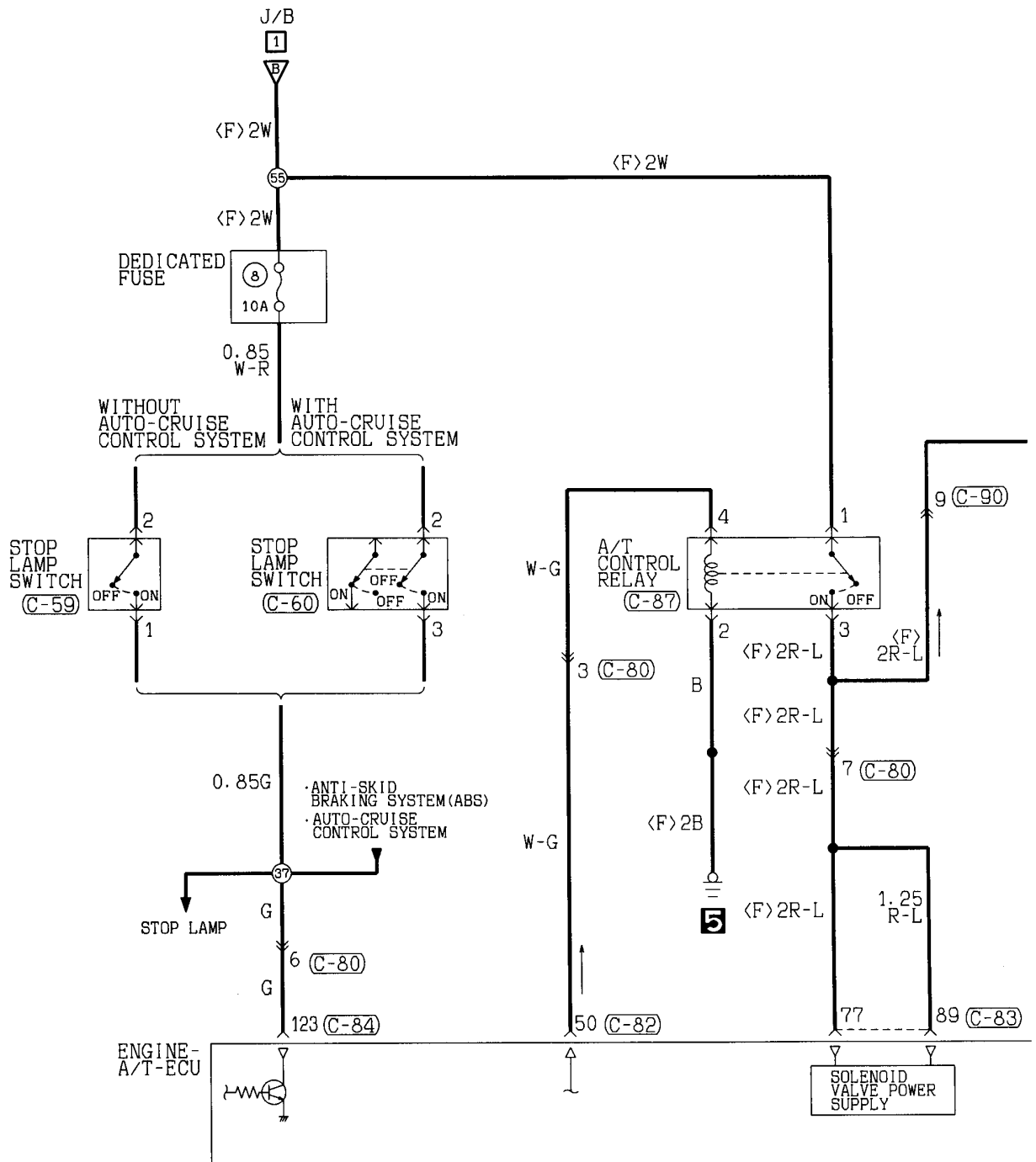

(B-09)

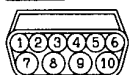

(C-59)



(C-60)



(C-80)

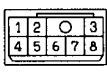

(C-82)

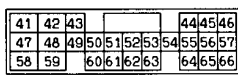

(C-83)

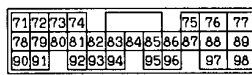

(C-84)

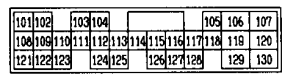

6

INPUT SHAFT
SPEED SENSOR,
OUTPUT SHAFT
SPEED SENSOR

- NOTE
- *1: UNDERDRIVE SOLENOID VALVE
 - *2: SECOND SOLENOID VALVE
 - *3: OVERDRIVE SOLENOID VALVE
 - *4: DAMPER CLUTCH CONTROL SOLENOID VALVE
 - *5: LOW AND REVERSE SOLENOID VALVE

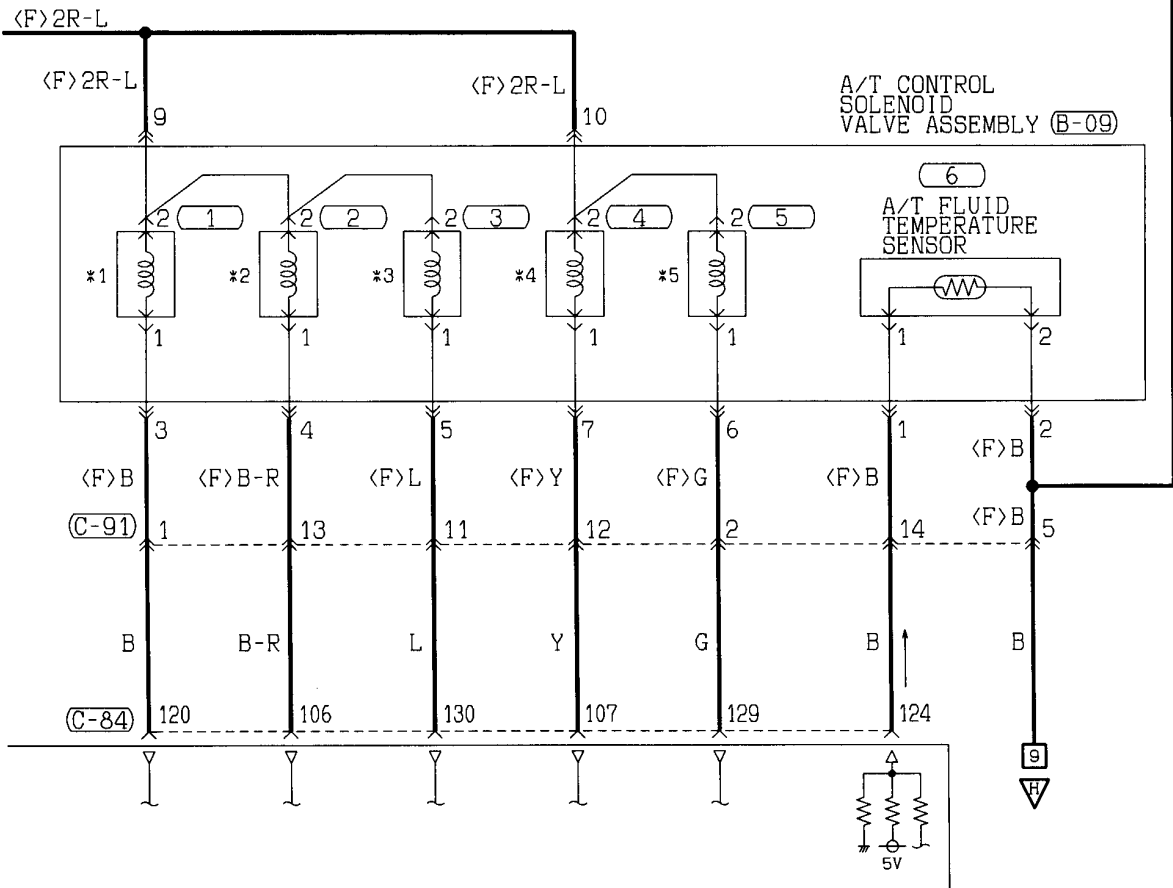

(C-87)

(C-90)

(C-91)

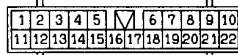
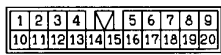

Wire colour code
 B : Black LG : Light green G : Green L : Blue W : White Y : Yellow SB : Sky blue
 BR : Brown O : Orange GR : Gray R : Red P : Pink V : Violet

INVECS-II 4A/T (CONTINUED)

7

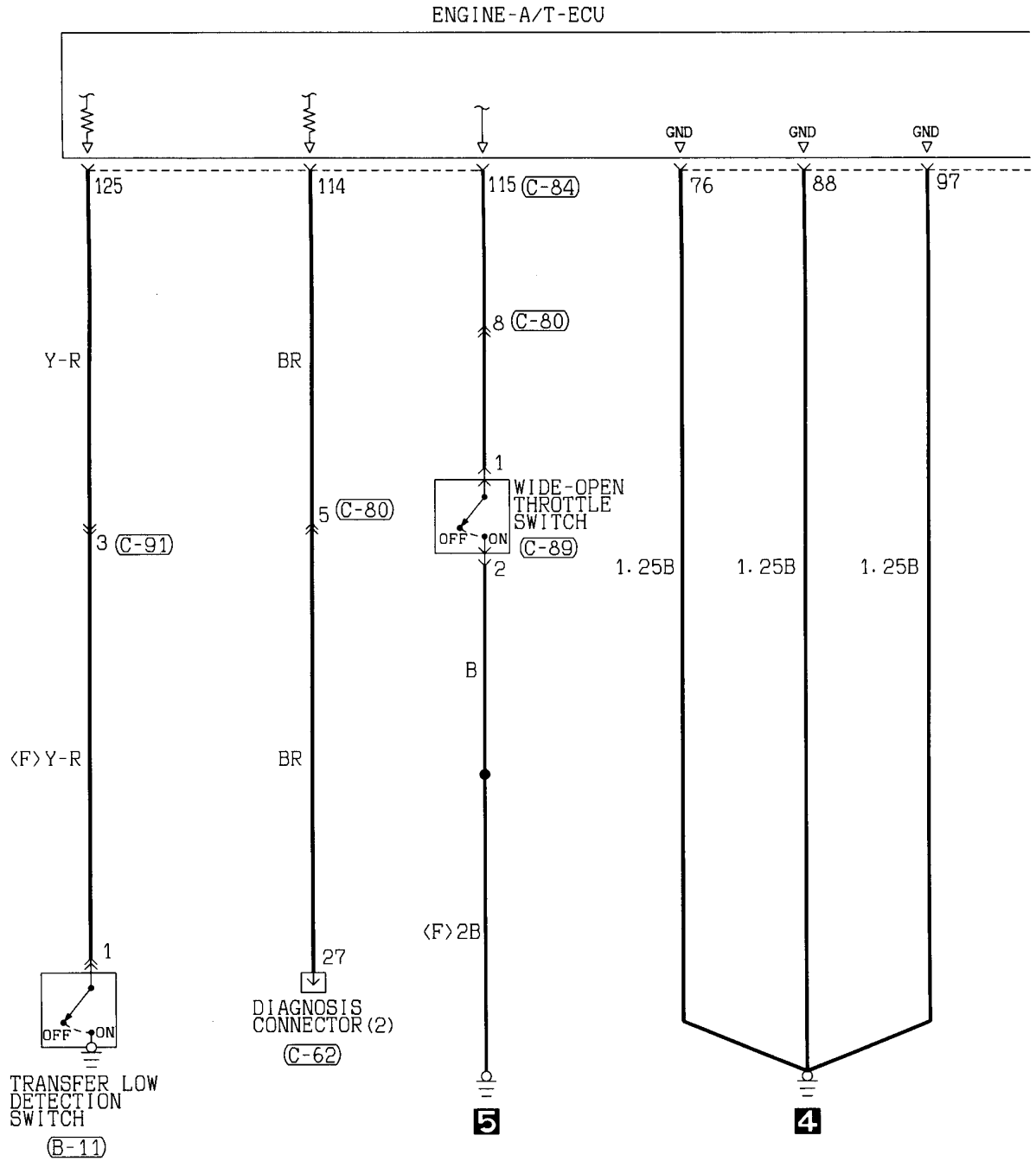

INVECS-II 4A/T (CONTINUED)

9

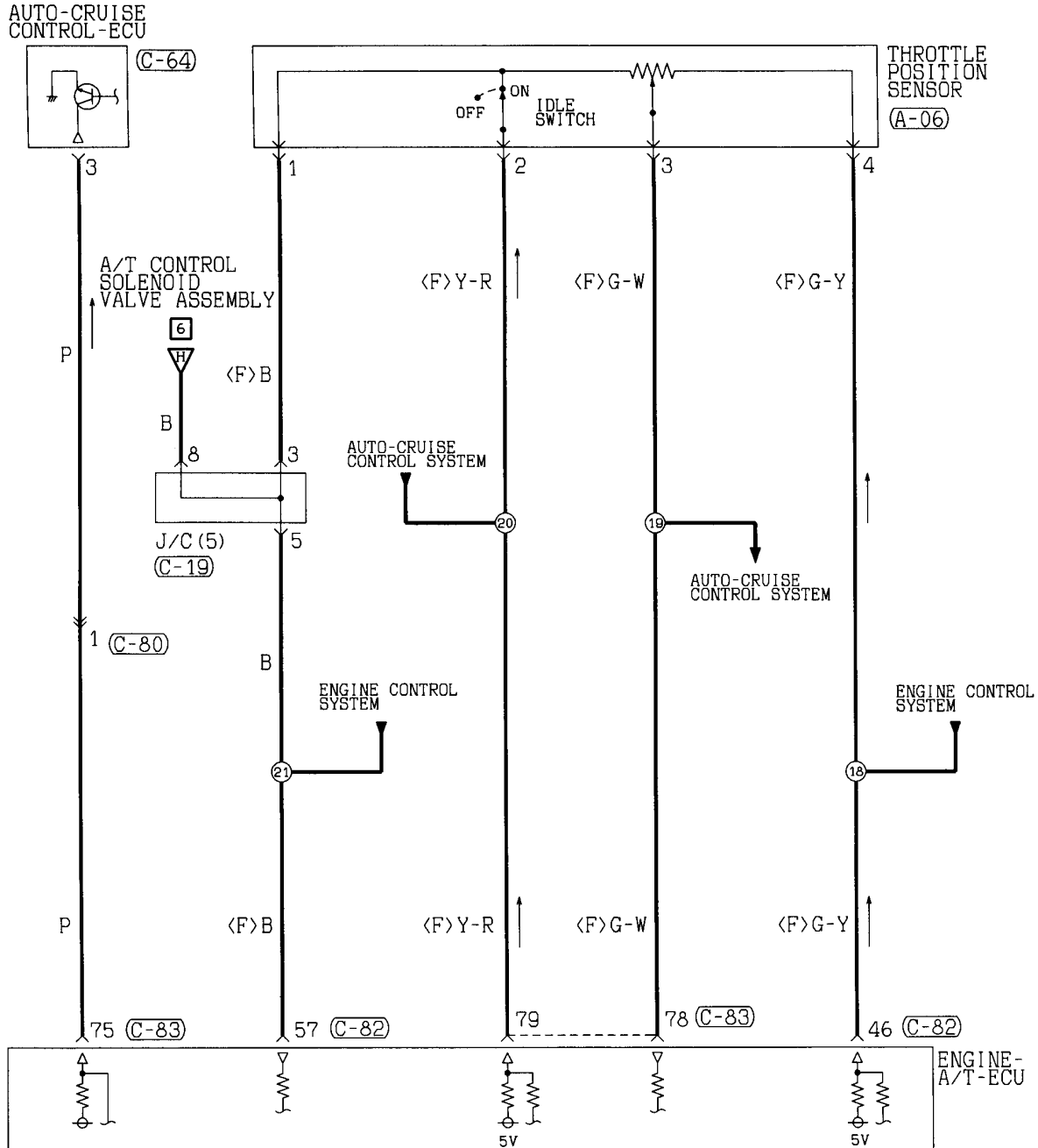

(A-06)	(C-19)	(C-64)	(C-80)	(C-82)	(C-83)
1 2 3 4	1 2 3 4 5 6 7 8 9 10 11 12 13 14 15 16 17 18 19 20 21 22 23 24 25 26 27 28 29 30 31 32 33	1 2 3 4 5 6 7 8 9 10 11 12 13 14 15 16	1 2 3 4 5 6 7 8	41 42 43 44 45 46 47 48 49 50 51 52 53 54 55 56 57 58 59 60 61 62 63 64 65 66	71 72 73 74 75 76 77 78 79 80 81 82 83 84 85 86 87 88 89 90 91 92 93 94 95 96 97 98

Wire colour code
 B : Black LG : Light green G : Green L : Blue W : White Y : Yellow SB : Sky blue
 BR : Brown O : Orange GR : Gray R : Red P : Pink V : Violet

NOTES

TAIL LAMP, POSITION LAMP AND LICENCE PLATE LAMP

L.H. drive vehicles

1

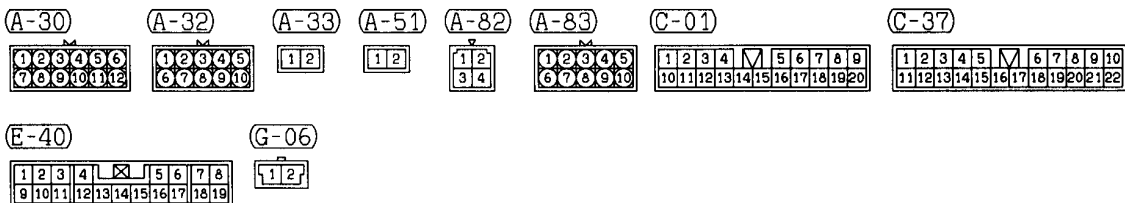
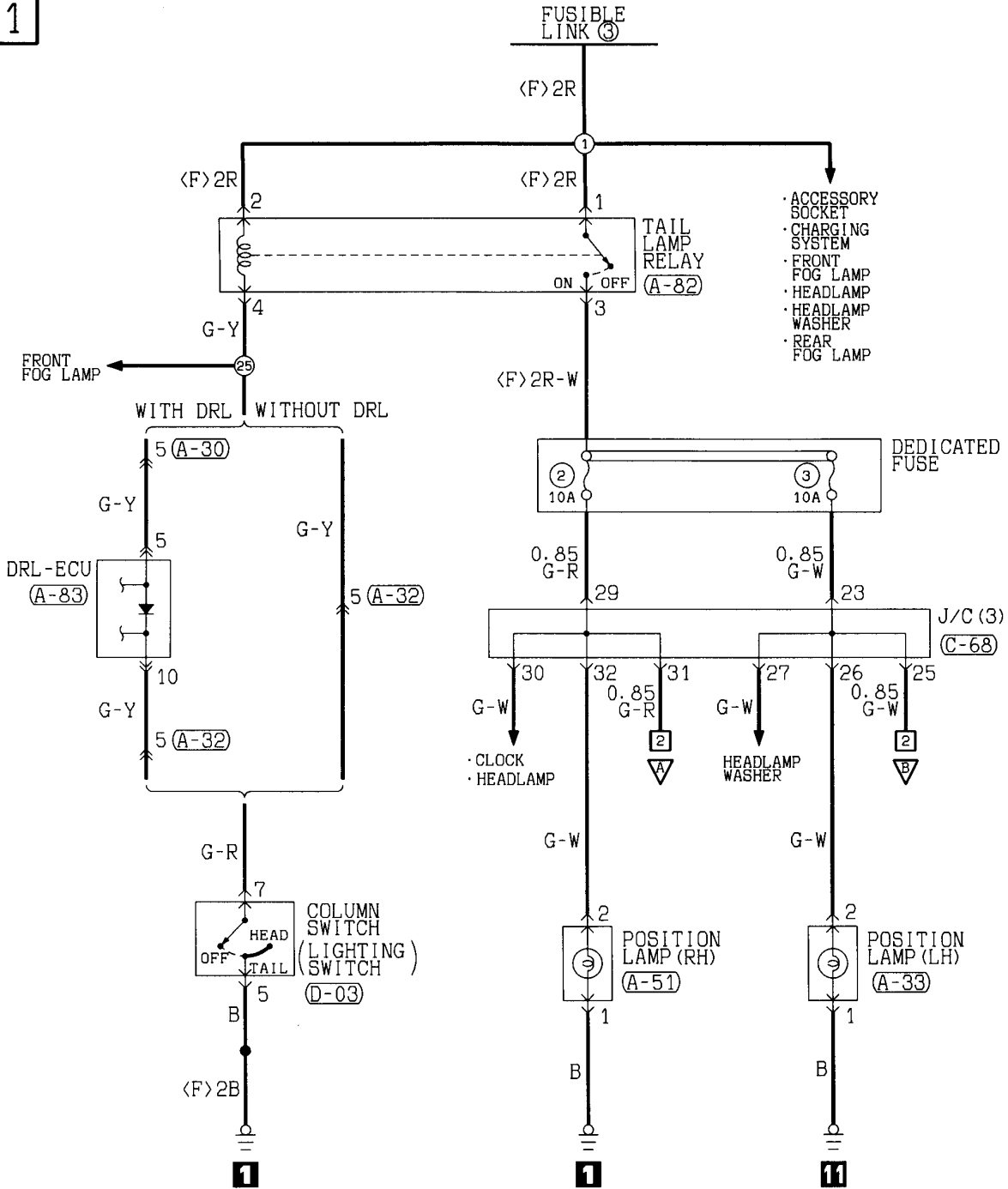

2

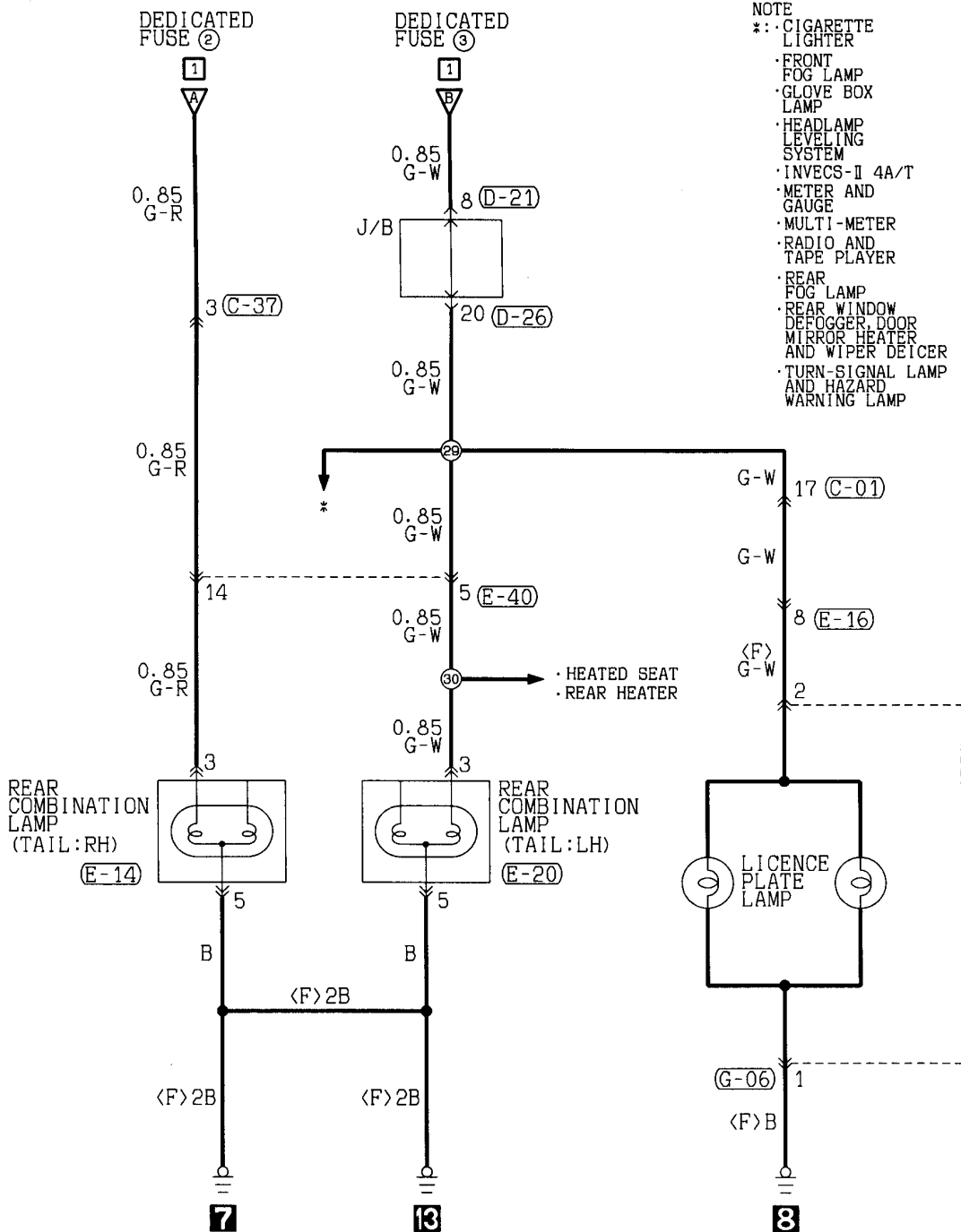

- NOTE
- *: CIGARETTE LIGHTER
 - FRONT FOG LAMP
 - GLOVE BOX LAMP
 - HEADLAMP LEVELING SYSTEM
 - INVECS-II 4A/T
 - METER AND GAUGE
 - MULTI-METER
 - RADIO AND TAPE PLAYER
 - REAR FOG LAMP
 - REAR WINDOW DEFOGGER, DOOR MIRROR HEATER AND WIPER DEICER
 - TURN-SIGNAL LAMP AND HAZARD WARNING LAMP

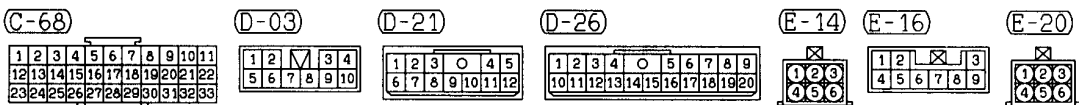

Wire colour code
 B : Black LG: Light green G : Green L : Blue W : White Y : Yellow SB: Sky blue
 BR: Brown O : Orange GR: Gray R : Red P : Pink V : Violet

TAIL LAMP, POSITION LAMP AND LICENCE PLATE LAMP

R.H. drive vehicles

1

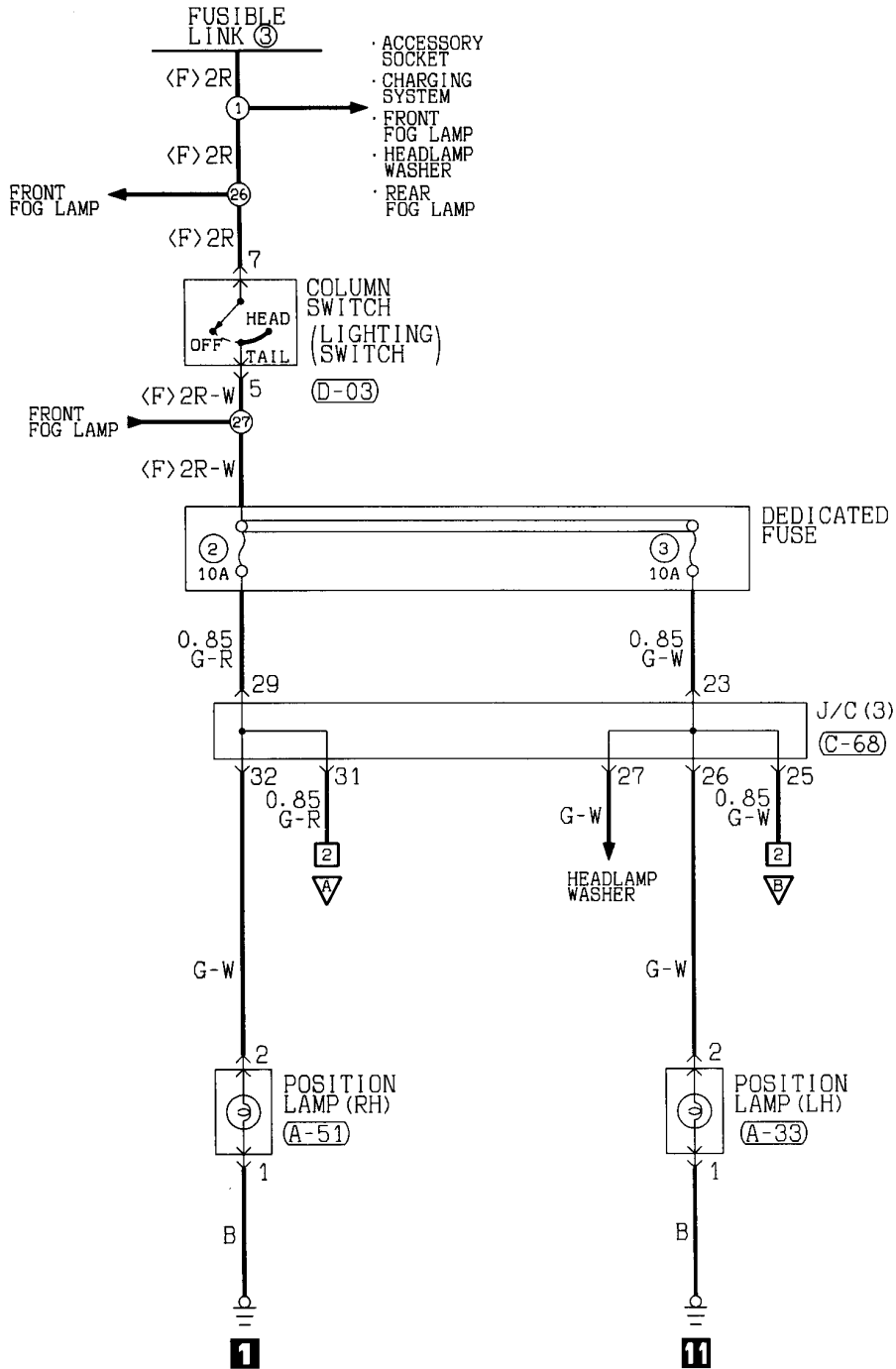

(A-33)

(A-51)

(C-01)

(C-37)

(C-68)

(D-03)

(D-21)

1	2
---	---

1	2
---	---

1	2	3	4	M	5	6	7	8	9	
10	11	12	13	14	15	16	17	18	19	20

1	2	3	4	5	M	6	7	8	9	10	
11	12	13	14	15	16	17	18	19	20	21	22

1	2	3	4	5	6	7	8	9	10	11
12	13	14	15	16	17	18	19	20	21	22
23	24	25	26	27	28	29	30	31	32	33

1	2	M	3	4	
5	6	7	8	9	10

1	2	3	0	4	5	
6	7	8	9	10	11	12

2

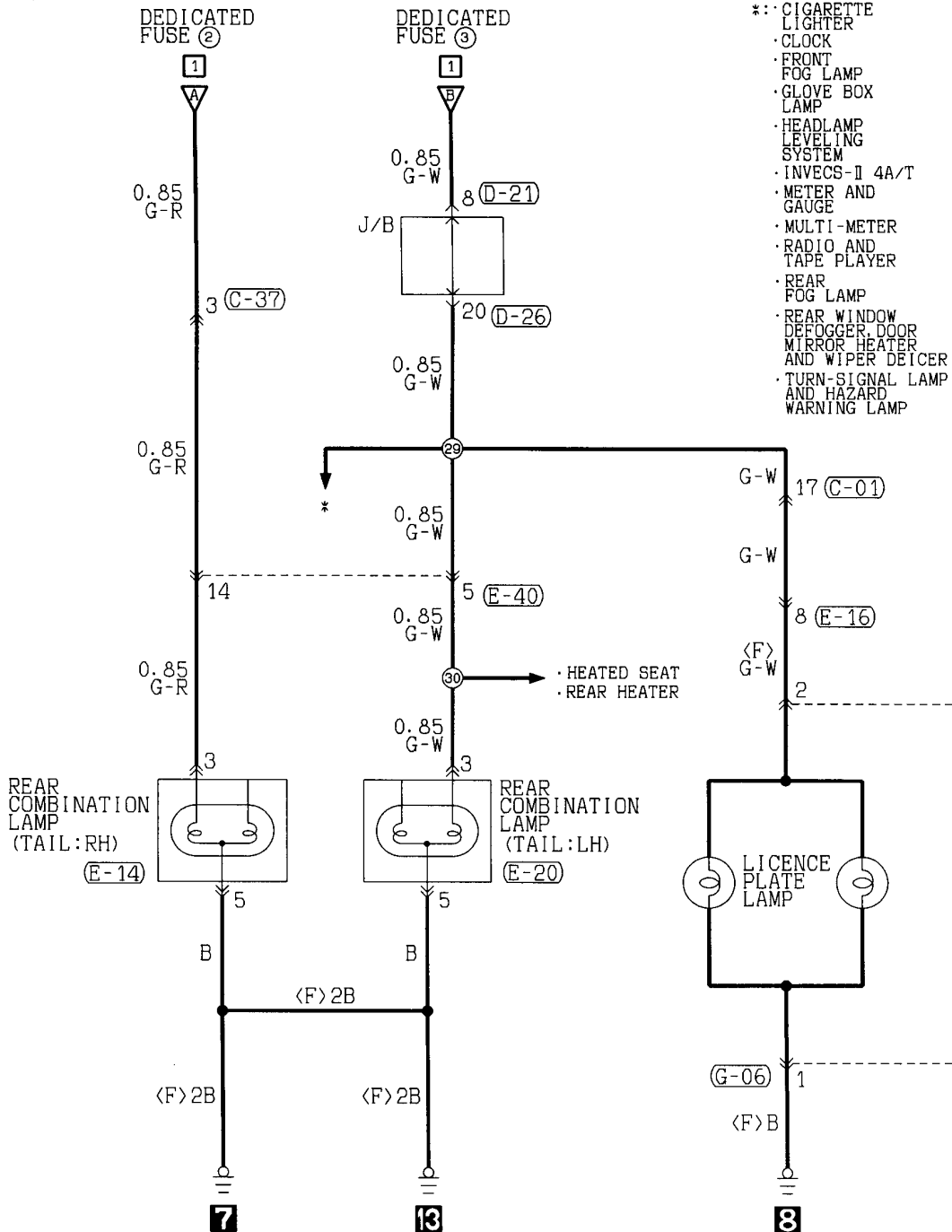

- NOTE
- *: CIGARETTE LIGHTER
 - CLOCK
 - FRONT FOG LAMP
 - GLOVE BOX LAMP
 - HEADLAMP LEVELING SYSTEM
 - INVECS-II 4A/T
 - METER AND GAUGE
 - MULTI-METER
 - RADIO AND TAPE PLAYER
 - REAR FOG LAMP
 - REAR WINDOW DEFOGGER, DOOR MIRROR HEATER AND WIPER DEICER
 - TURN-SIGNAL LAMP AND HAZARD WARNING LAMP

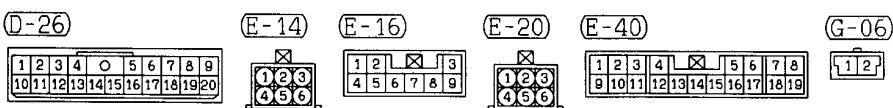

Wire colour code
 B :Black LG:Light green G :Green L :Blue W :White Y :Yellow SB:Sky blue
 BR:Brown O :Orange GR:Gray R :Red P :Pink V :Violet

FRONT FOG LAMP

L.H. drive vehicles

1

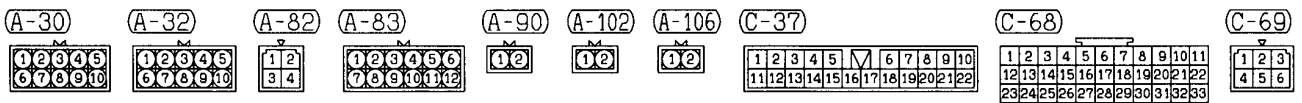
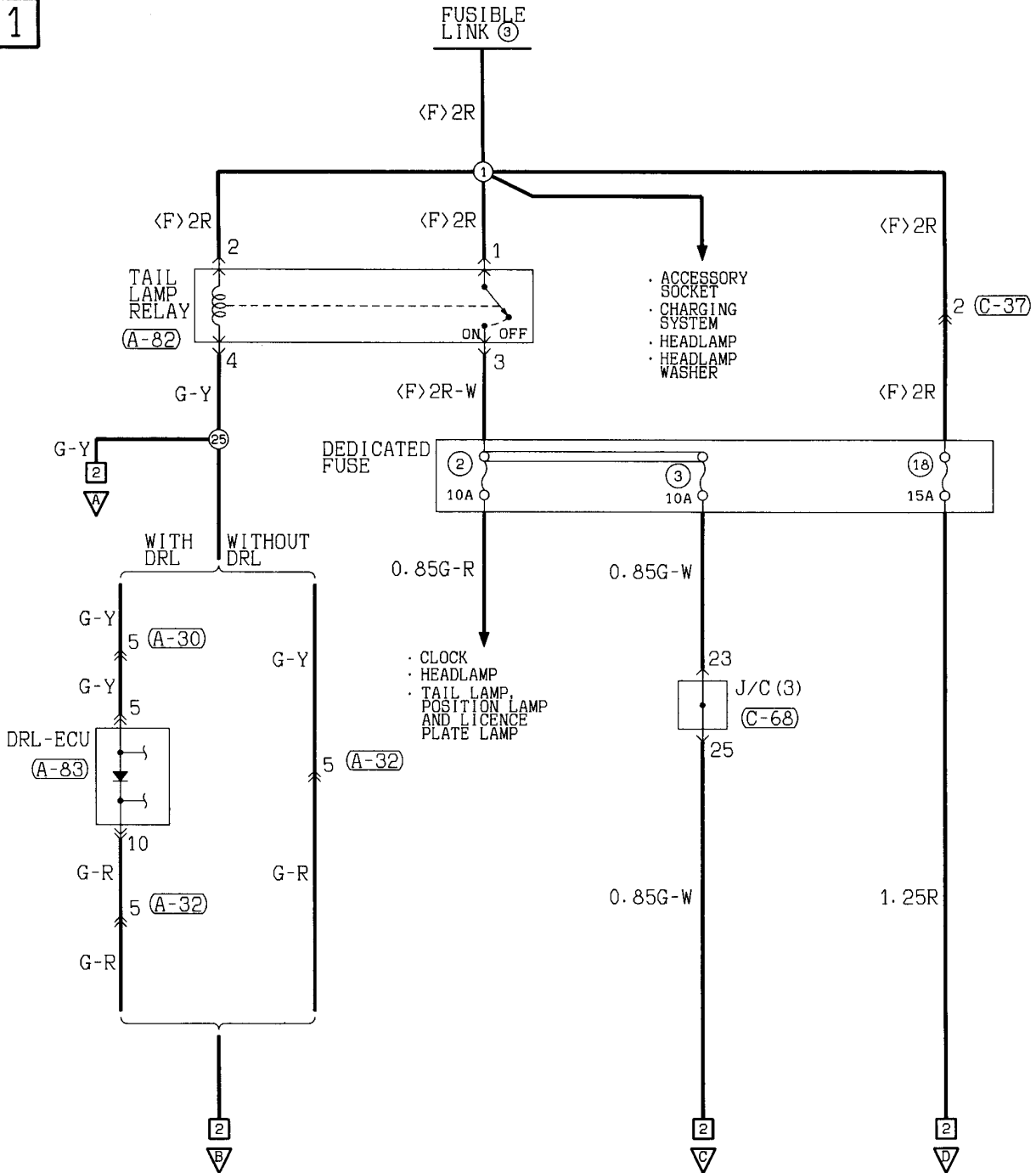

2

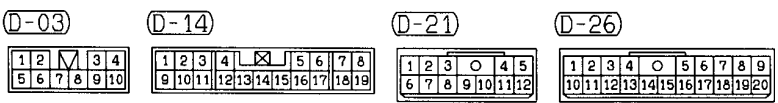
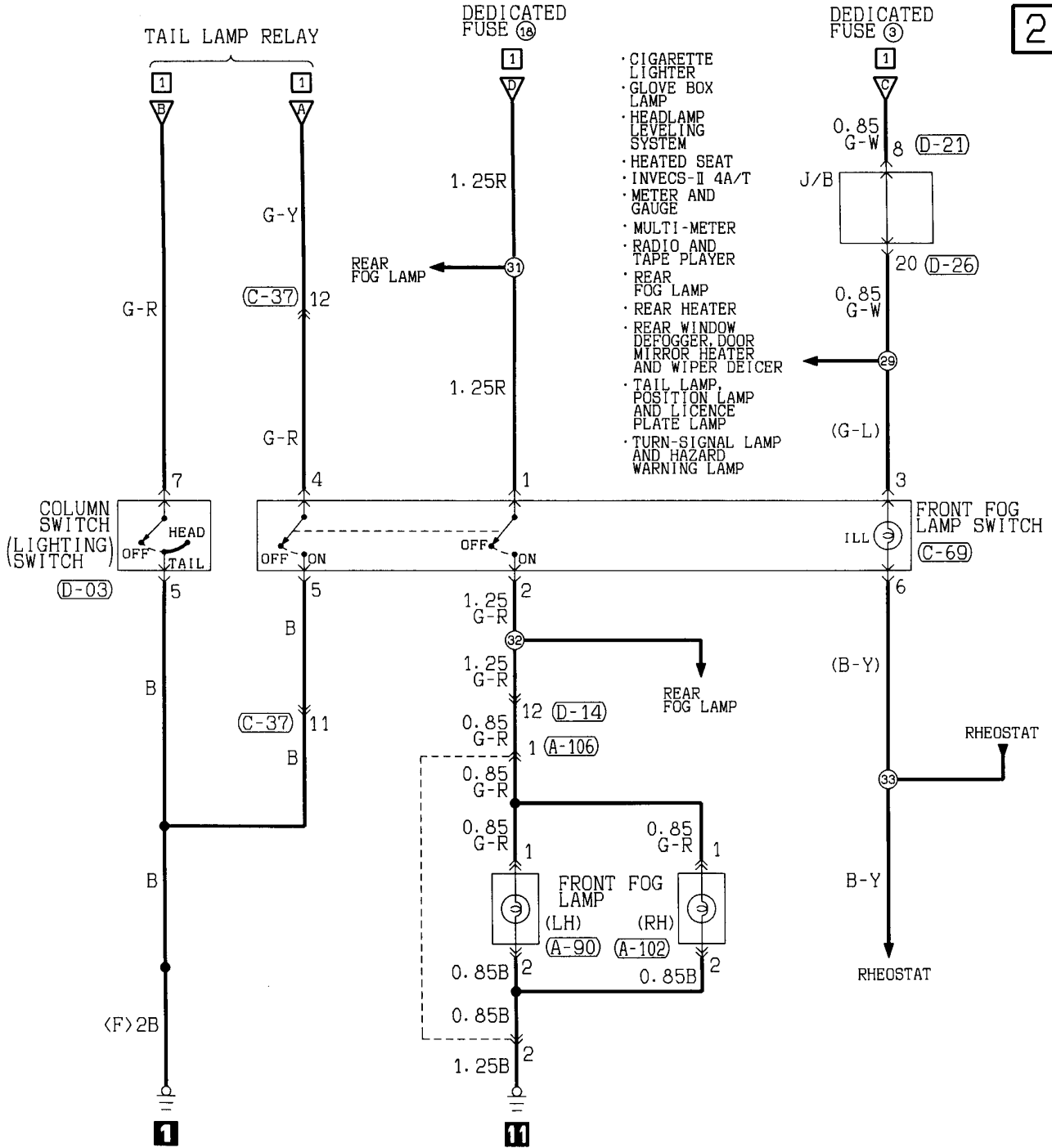

Wire colour code
 B : Black LG: Light green G : Green L : Blue W : White Y : Yellow SB: Sky blue
 BR: Brown O : Orange GR: Gray R : Red P : Pink V : Violet

FRONT FOG LAMP

R.H. drive vehicles

1

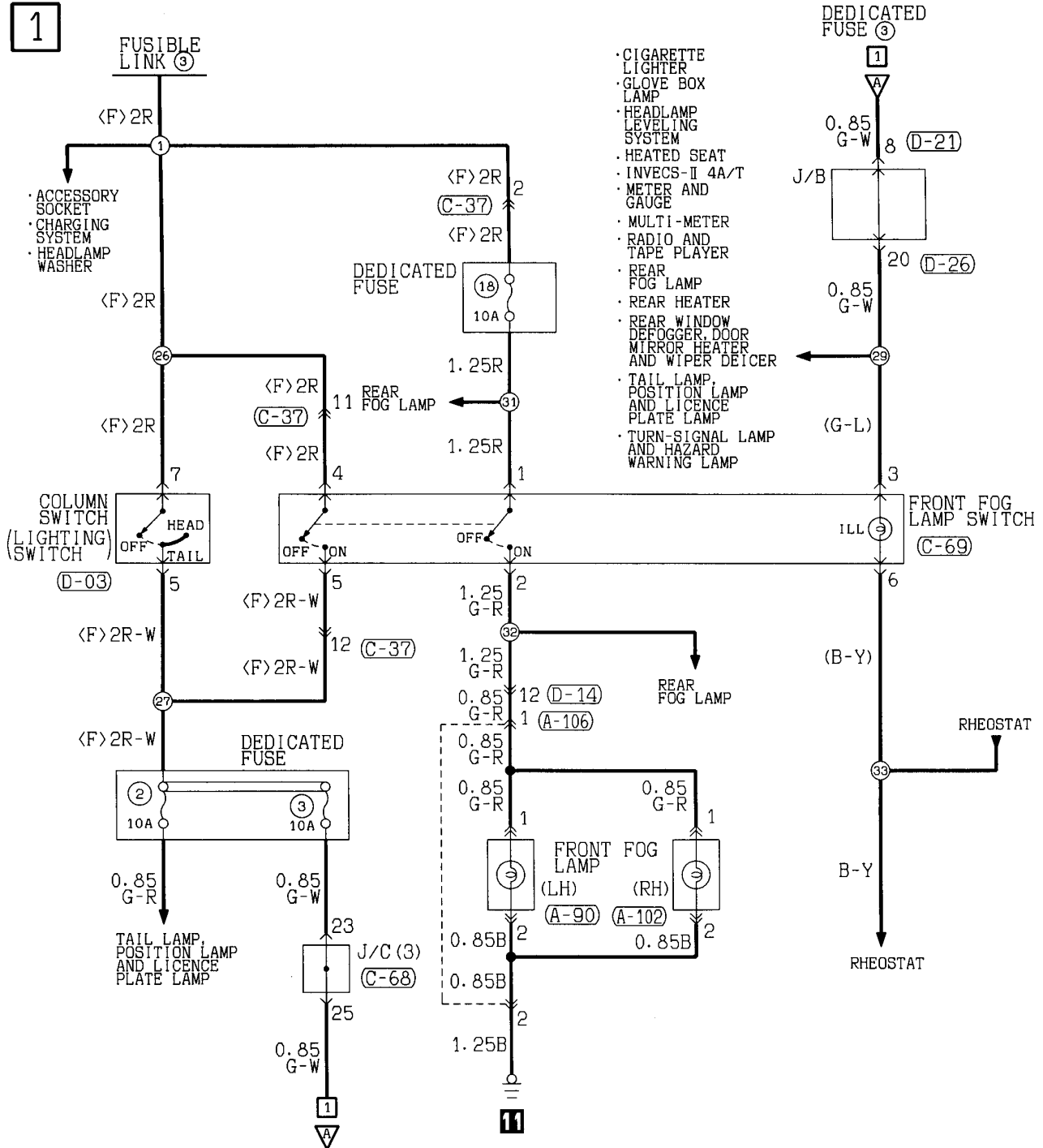

(A-90) (A-102) (A-106) (C-37)



(C-68)

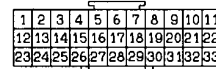

(C-69) (D-03) (D-14)

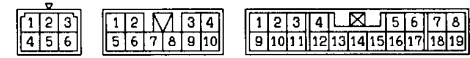

(D-21) (D-26)

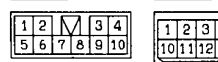

Wire colour code
 B : Black LG : Light green G : Green L : Blue
 BR : Brown O : Orange GR : Gray R : Red
 W : White SB : Sky blue P : Pink Y : Yellow
 V : Violet

NOTES

REAR FOG LAMP

L.H. drive vehicles

1

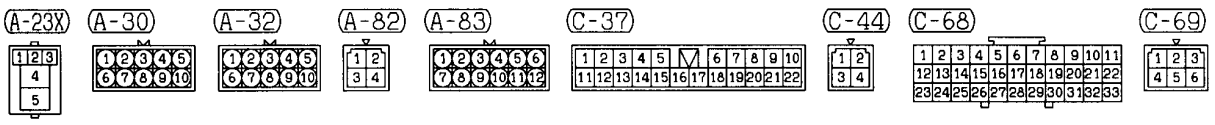
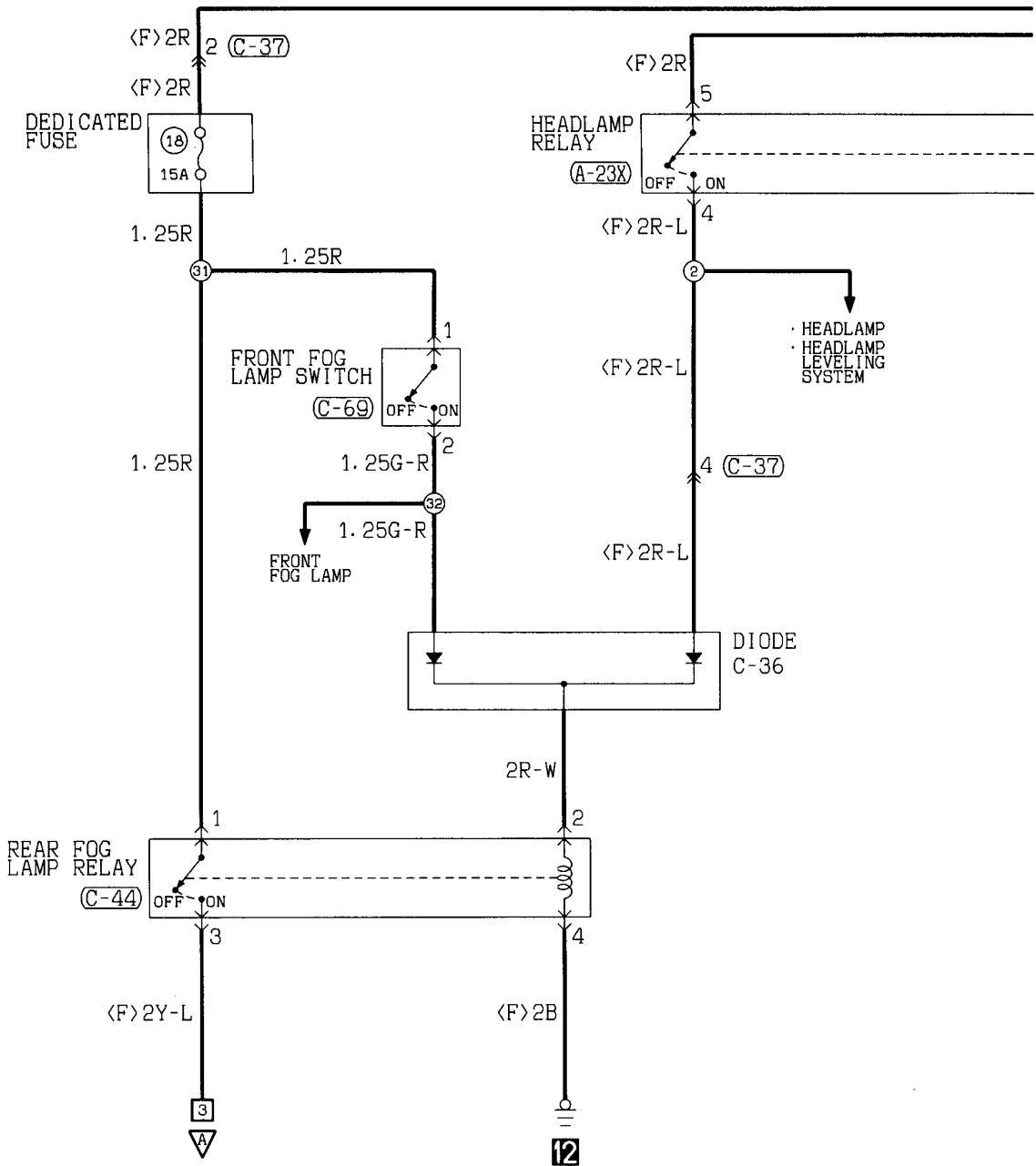

2

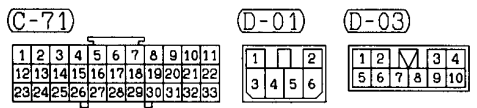
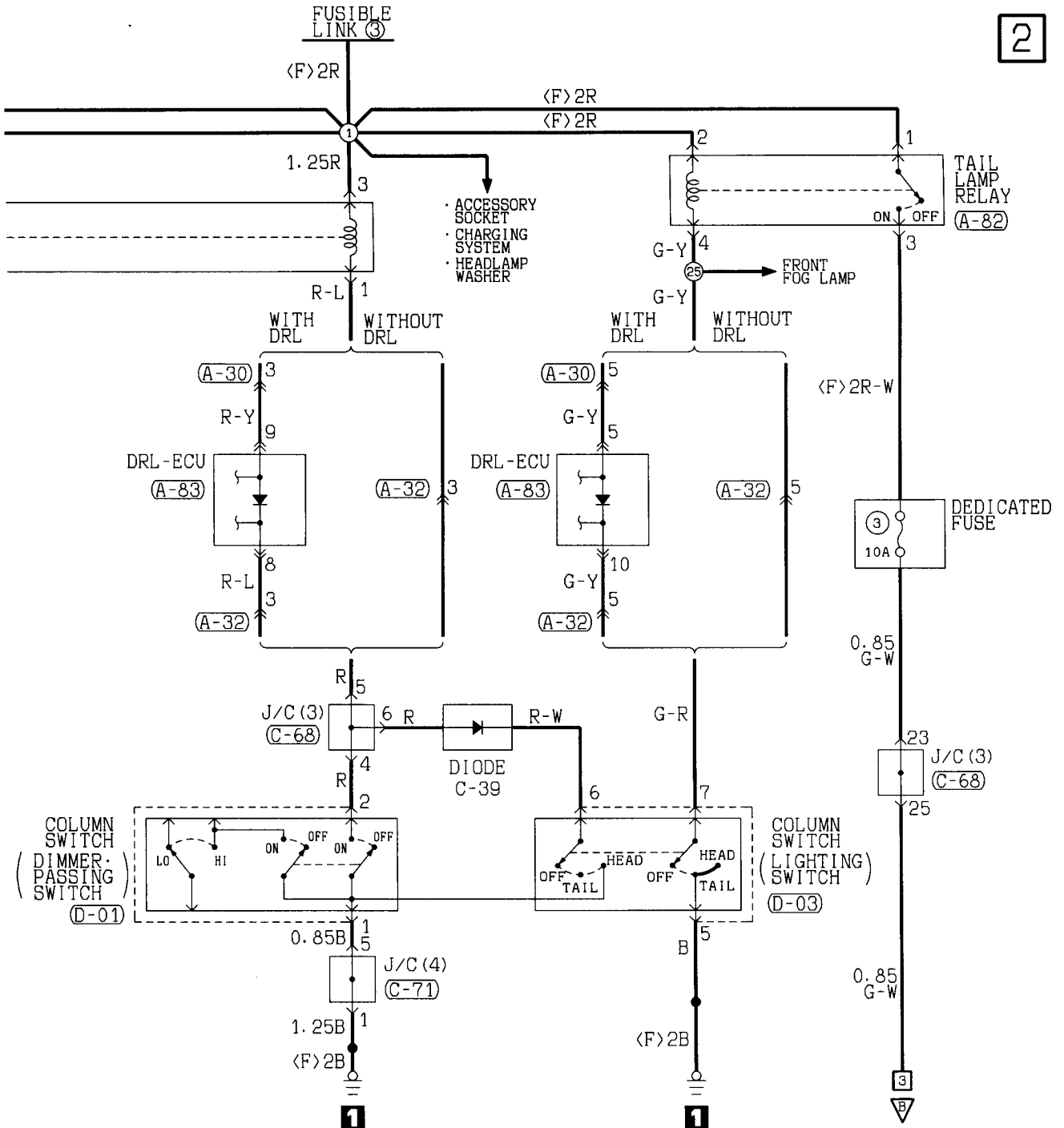

Wire colour code
 B : Black LG: Light green G : Green L : Blue W : White Y : Yellow SB: Sky blue
 BR: Brown O : Orange GR: Gray R : Red P : Pink V : Violet

REAR FOG LAMP <L.H. drive vehicles> (CONTINUED)

3

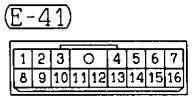
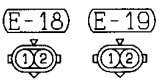
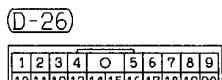
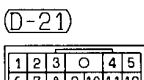
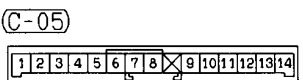
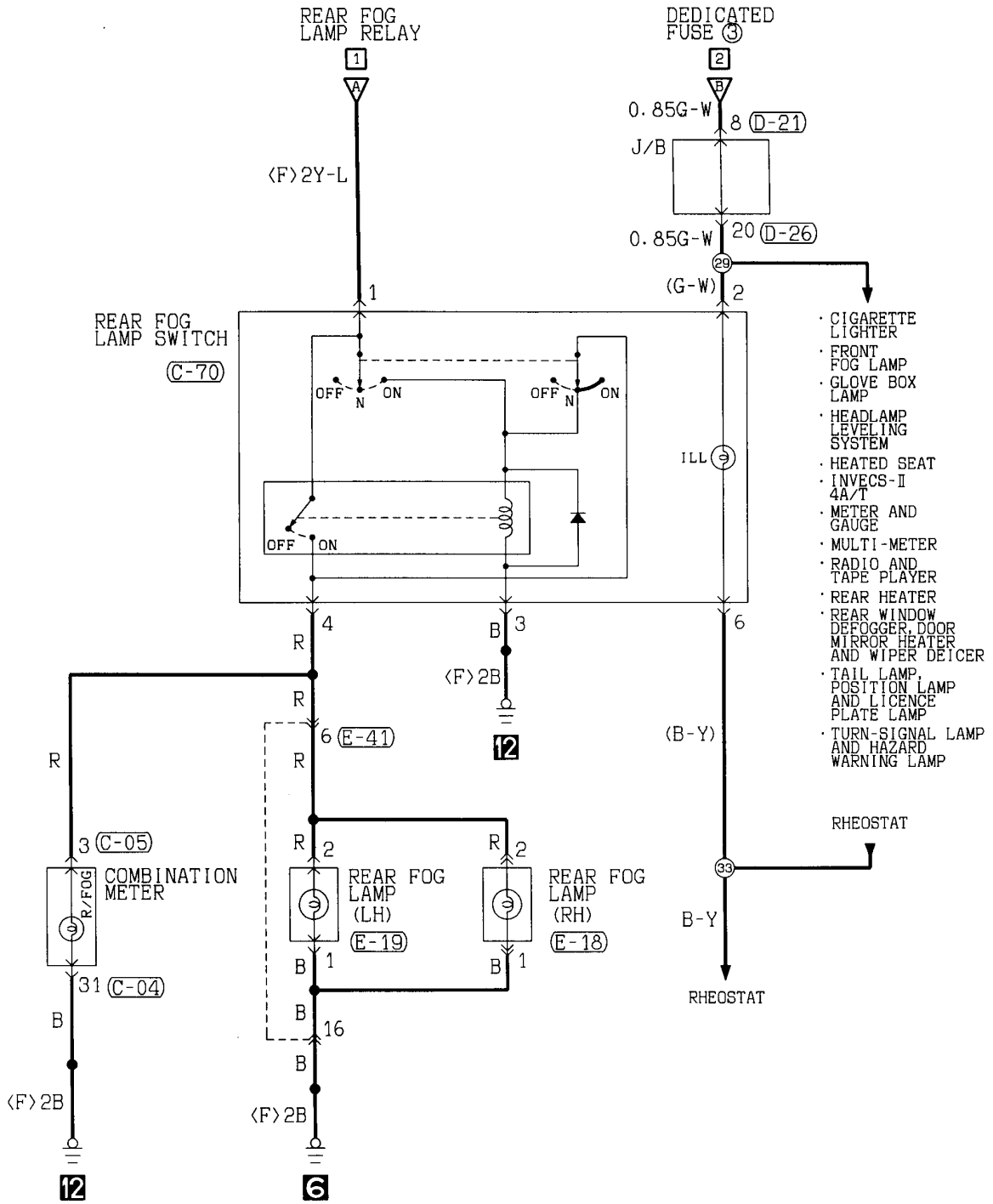

Wire colour code
 B : Black LG : Light green G : Green L : Blue W : White Y : Yellow SB : Sky blue
 BR : Brown O : Orange GR : Gray R : Red P : Pink V : Violet

NOTES

REAR FOG LAMP

R.H. drive vehicles

1

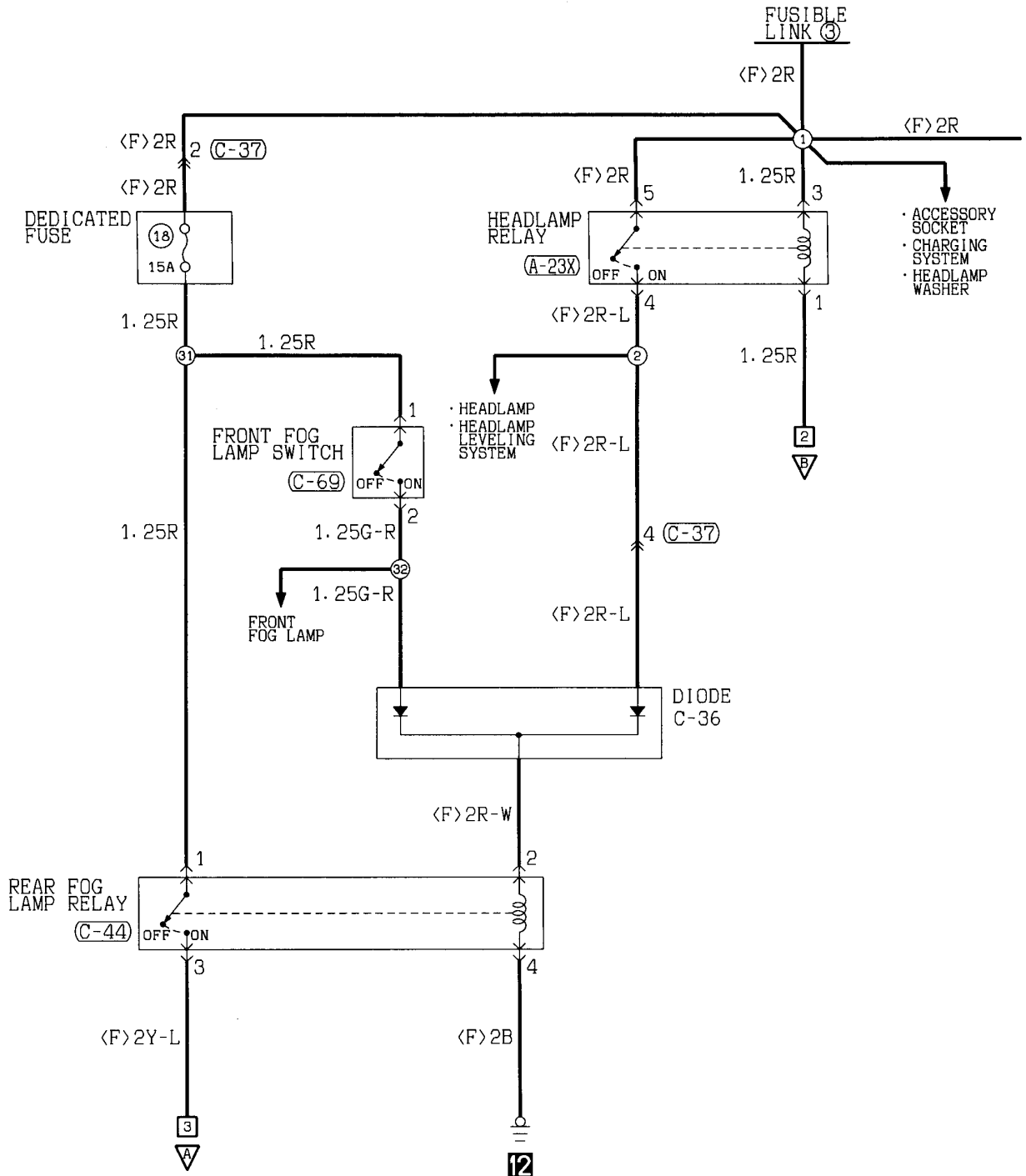

(A-23X)

1	2	3
4		
5		

(C-37)

1	2	3	4	5	6	7	8	9	10		
11	12	13	14	15	16	17	18	19	20	21	22

(C-44)

1	2
3	4

(C-68)

1	2	3	4	5	6	7	8	9	10	11
12	13	14	15	16	17	18	19	20	21	22
23	24	25	26	27	28	29	30	31	32	33

(C-69)

1	2	3
4	5	6

(C-71)

1	2	3	4	5	6	7	8	9	10	11
12	13	14	15	16	17	18	19	20	21	22
23	24	25	26	27	28	29	30	31	32	33

(D-01)

1		2	
3	4	5	6

(D-03)

1	2	3	4		
5	6	7	8	9	10

2

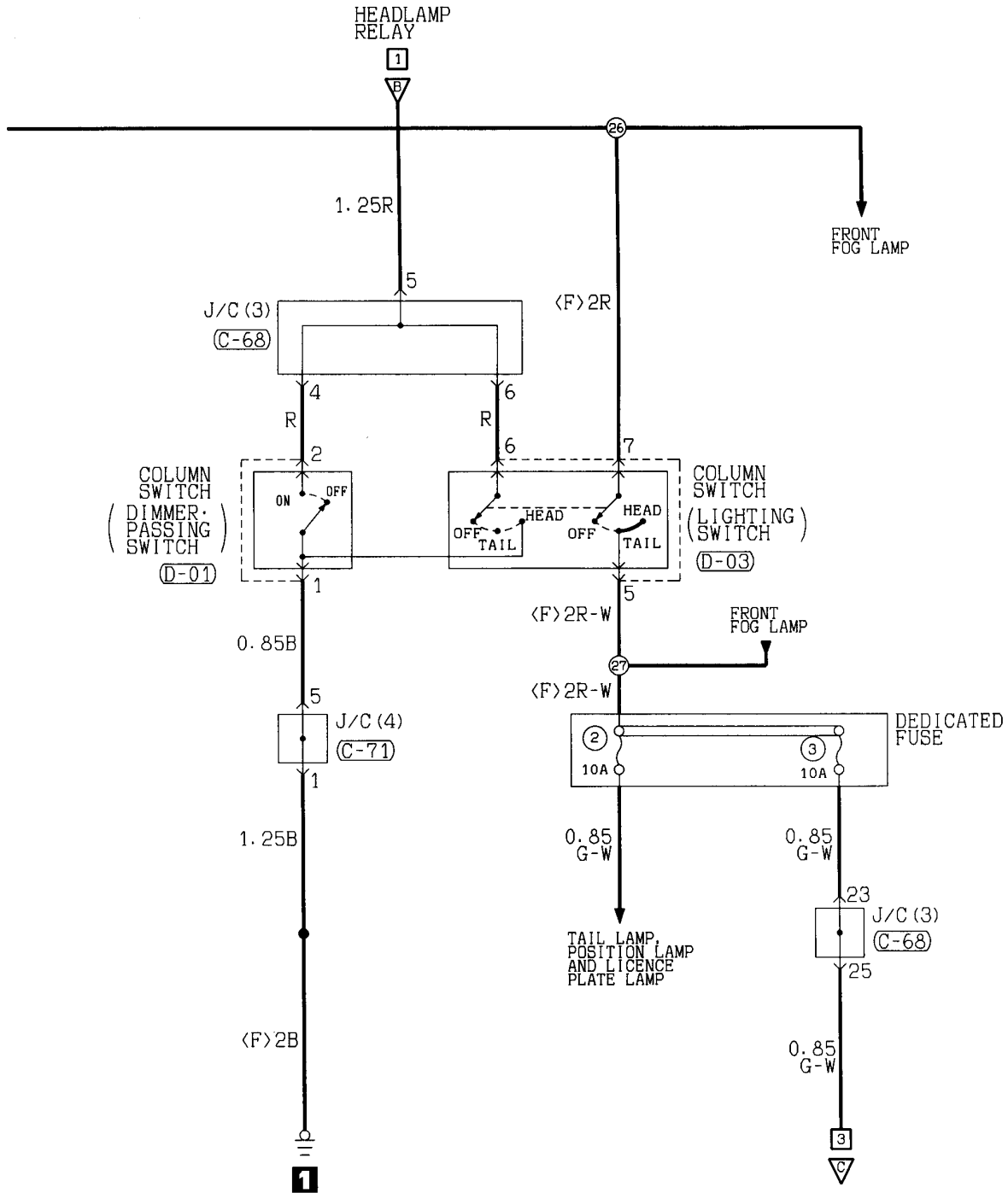

Wire colour code
 B :Black LG:Light green G :Green L :Blue W :White Y :Yellow SB:Sky blue
 BR:Brown O :Orange GR:Gray R :Red P :Pink V :Violet

REAR FOG LAMP <R.H. drive vehicles> (CONTINUED)

3

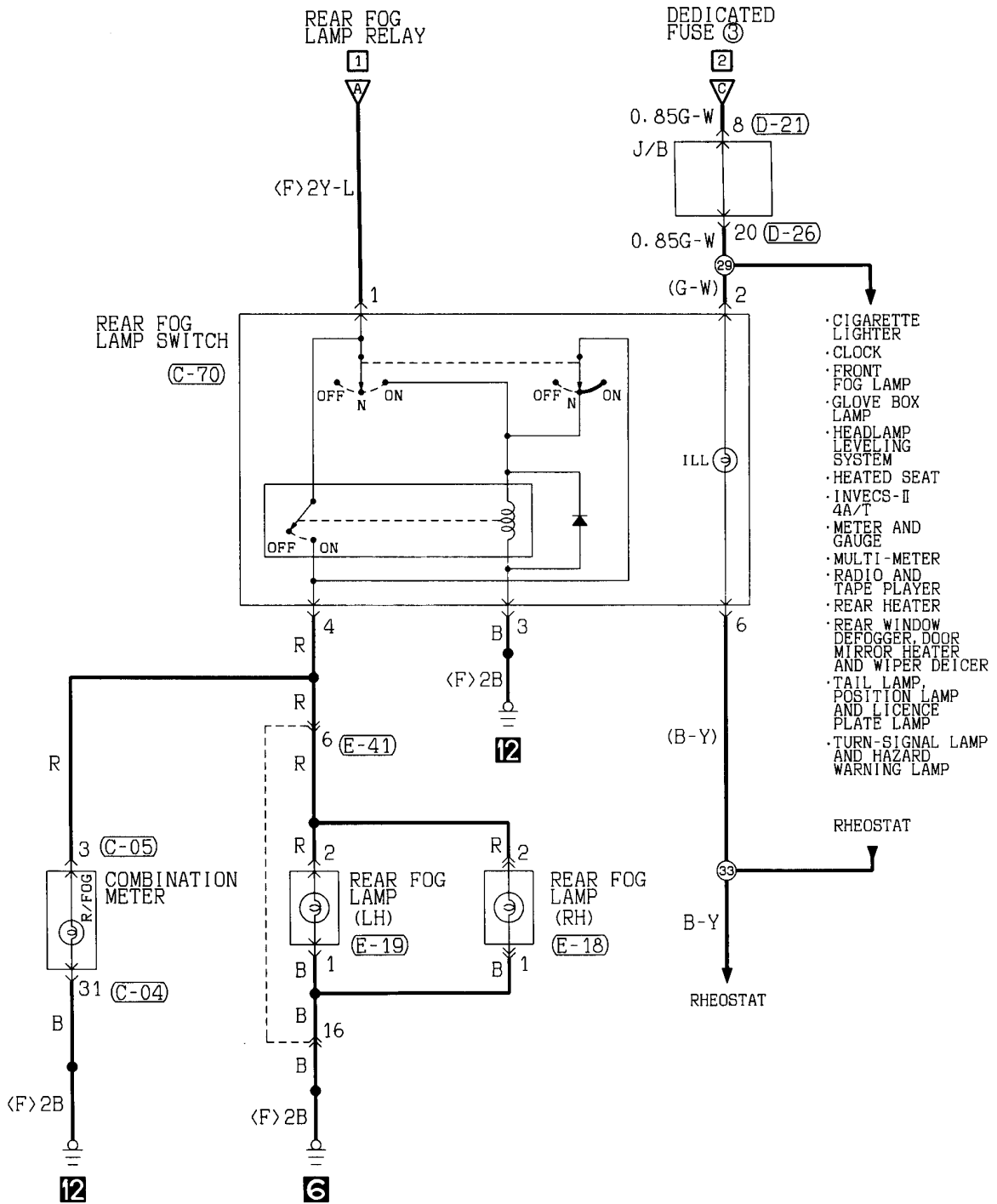

- CIGARETTE LIGHTER
- CLOCK
- FRONT FOG LAMP
- GLOVE BOX LAMP
- HEADLAMP LEVELING SYSTEM
- HEATED SEAT
- INVECS-II 4A/T
- METER AND GAUGE
- MULTI-METER
- RADIO AND TAPE PLAYER
- REAR HEATER
- REAR WINDOW DEFROGGER, DOOR MIRROR HEATER AND WIPER DEICER
- TAIL LAMP, POSITION LAMP AND LICENCE PLATE LAMP
- TURN-SIGNAL LAMP AND HAZARD WARNING LAMP

C-04

2	1	2	23	24	25	26	27	X	28	29	30	31	32
---	---	---	----	----	----	----	----	---	----	----	----	----	----

C-05

1	2	3	4	5	6	7	8	X	9	10	11	12	13	14
---	---	---	---	---	---	---	---	---	---	----	----	----	----	----

C-70

1	M	2
3	4	5

D-21

1	2	3	0	4	5	
6	7	8	9	10	11	12

D-26

1	2	3	4	0	5	6	7	8	9	
10	11	12	13	14	15	16	17	18	19	20

E-18

1	2
---	---

E-19

1	2
---	---

E-41

1	2	3	0	4	5	6	7	
8	9	10	11	12	13	14	15	16

Wire colour code
 B : Black LG : Light green G : Green L : Blue W : White Y : Yellow SB : Sky blue
 BR : Brown O : Orange GR : Gray R : Red P : Pink V : Violet

GLOVE BOX LAMP

1

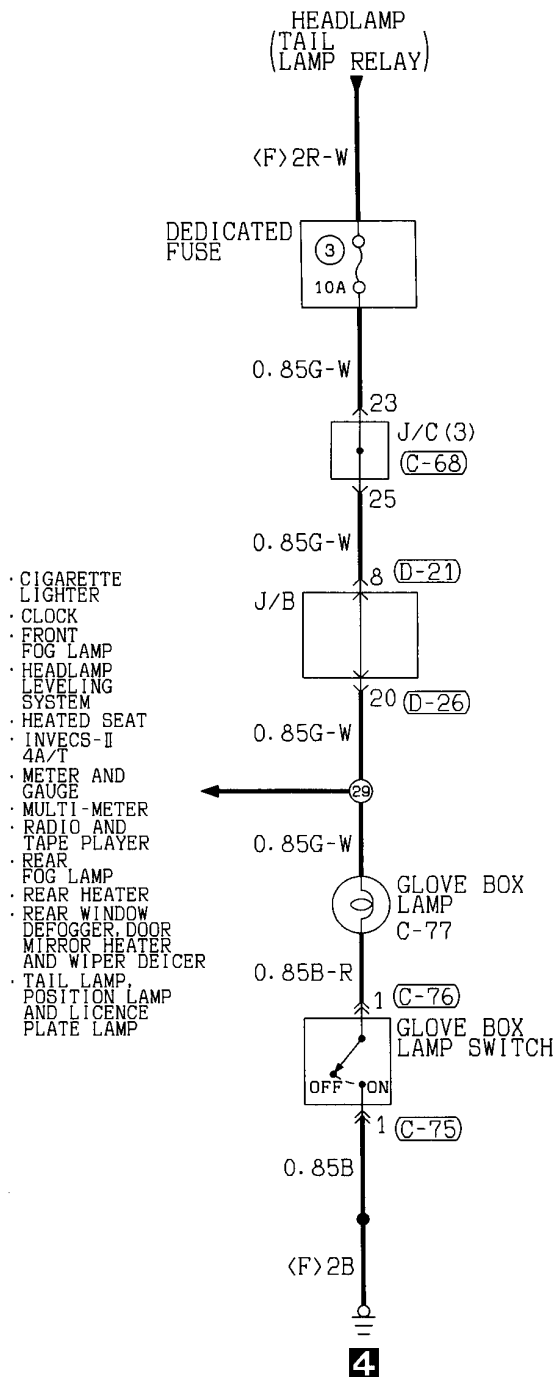

- CIGARETTE LIGHTER
- CLOCK
- FRONT FOG LAMP
- HEADLAMP LEVELING SYSTEM
- HEATED SEAT
- INVECS-II 4A/T
- METER AND GAUGE
- MULTI-METER
- RADIO AND TAPE PLAYER
- REAR FOG LAMP
- REAR HEATER
- REAR WINDOW DEFOGGER, DOOR MIRROR HEATER AND WIPER DEICER
- TAIL LAMP, POSITION LAMP AND LICENCE PLATE LAMP

(C-68)

1	2	3	4	5	6	7	8	9	10	11
12	13	14	15	16	17	18	19	20	21	22
23	24	25	26	27	28	29	30	31	32	33

(C-75)



(C-76)



(D-21)

1	2	3	0	4	5	
6	7	8	9	10	11	12

(D-26)

1	2	3	4	0	5	6	7	8	9	
10	11	12	13	14	15	16	17	18	19	20

Wire colour code

B : Black LG:Light green G :Green L :Blue W :White Y :Yellow SB:Sky blue
 BR:Brown O :Orange GR:Gray R :Red P :Pink V :Violet

HEADLAMP LEVELING SYSTEM

1

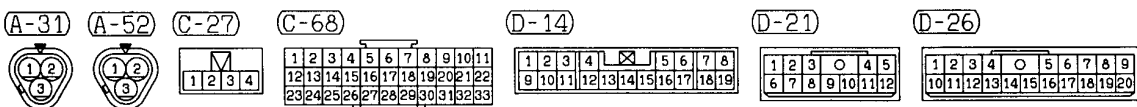
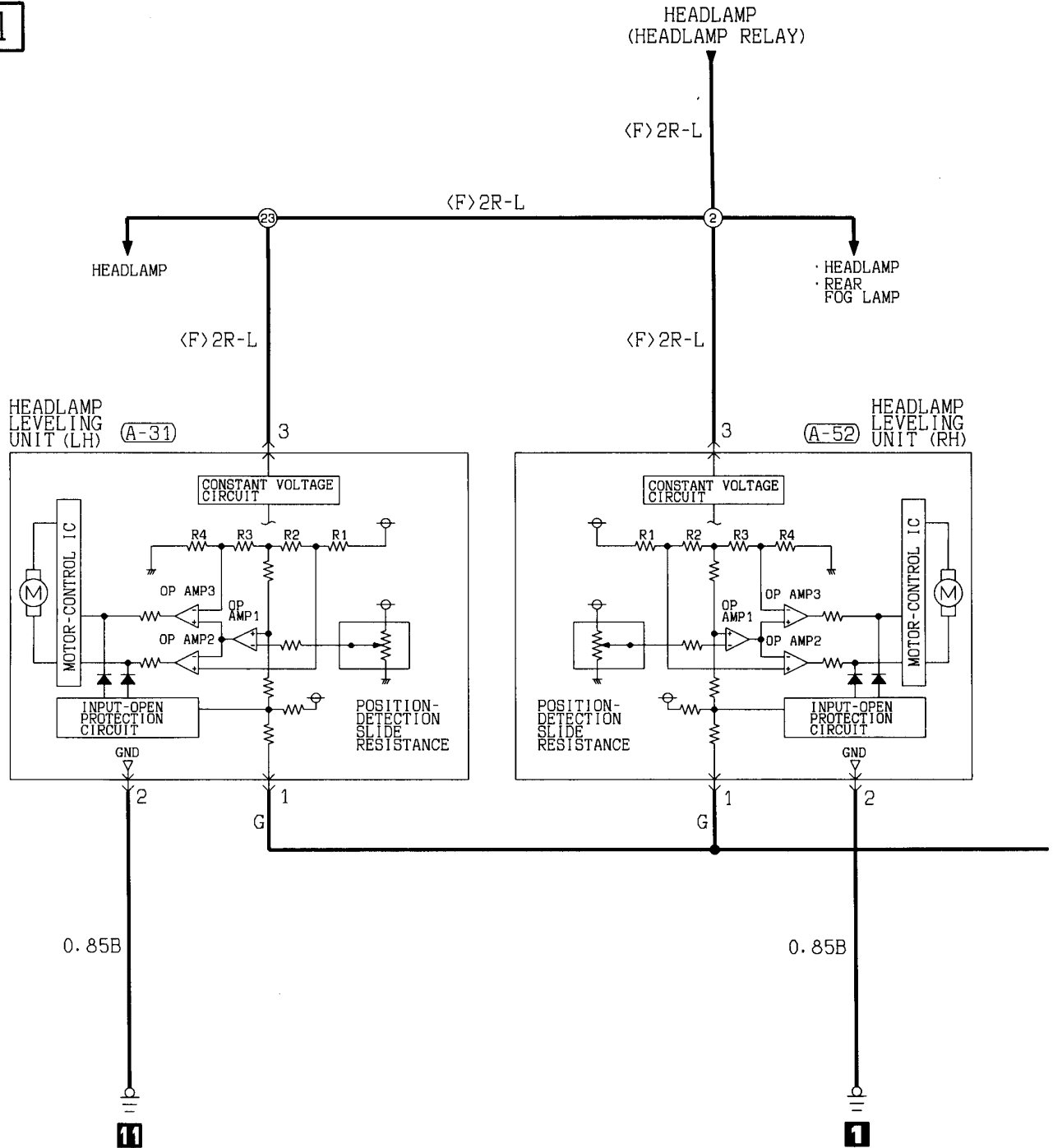

2

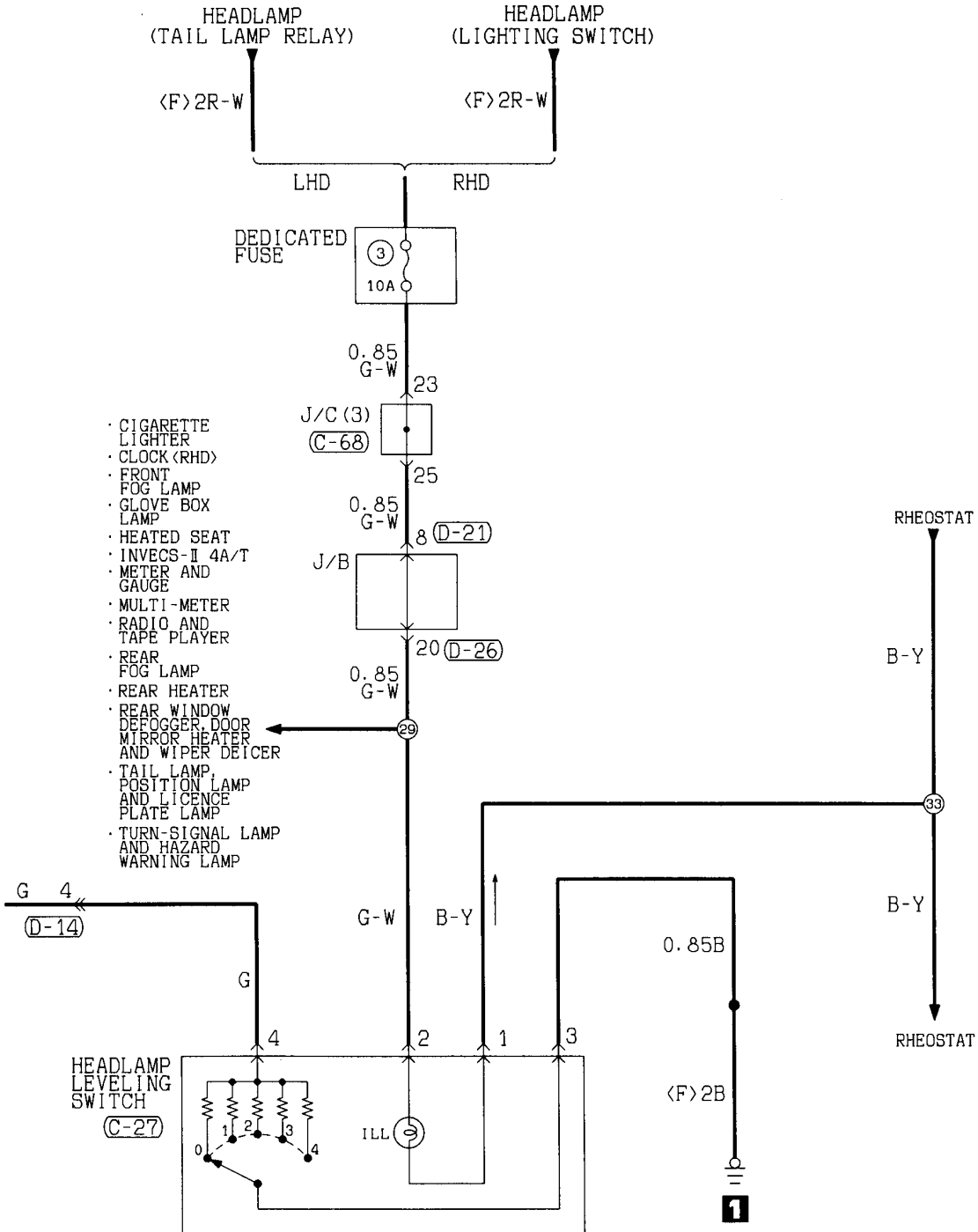

Wire colour code
 B :Black LG:Light green G :Green L :Blue W :White Y :Yellow SB:Sky blue
 BR:Brown O :Orange GR:Gray R :Red P :Pink V :Violet

ROOM LAMP, MAP LAMP AND LUGGAGE COMPARTMENT LAMP

Vehicles with keyless entry system

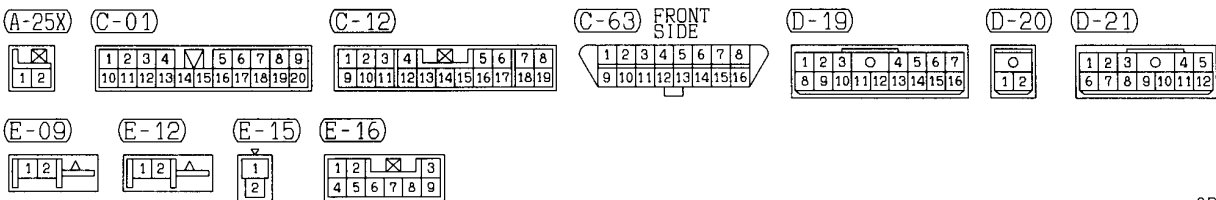
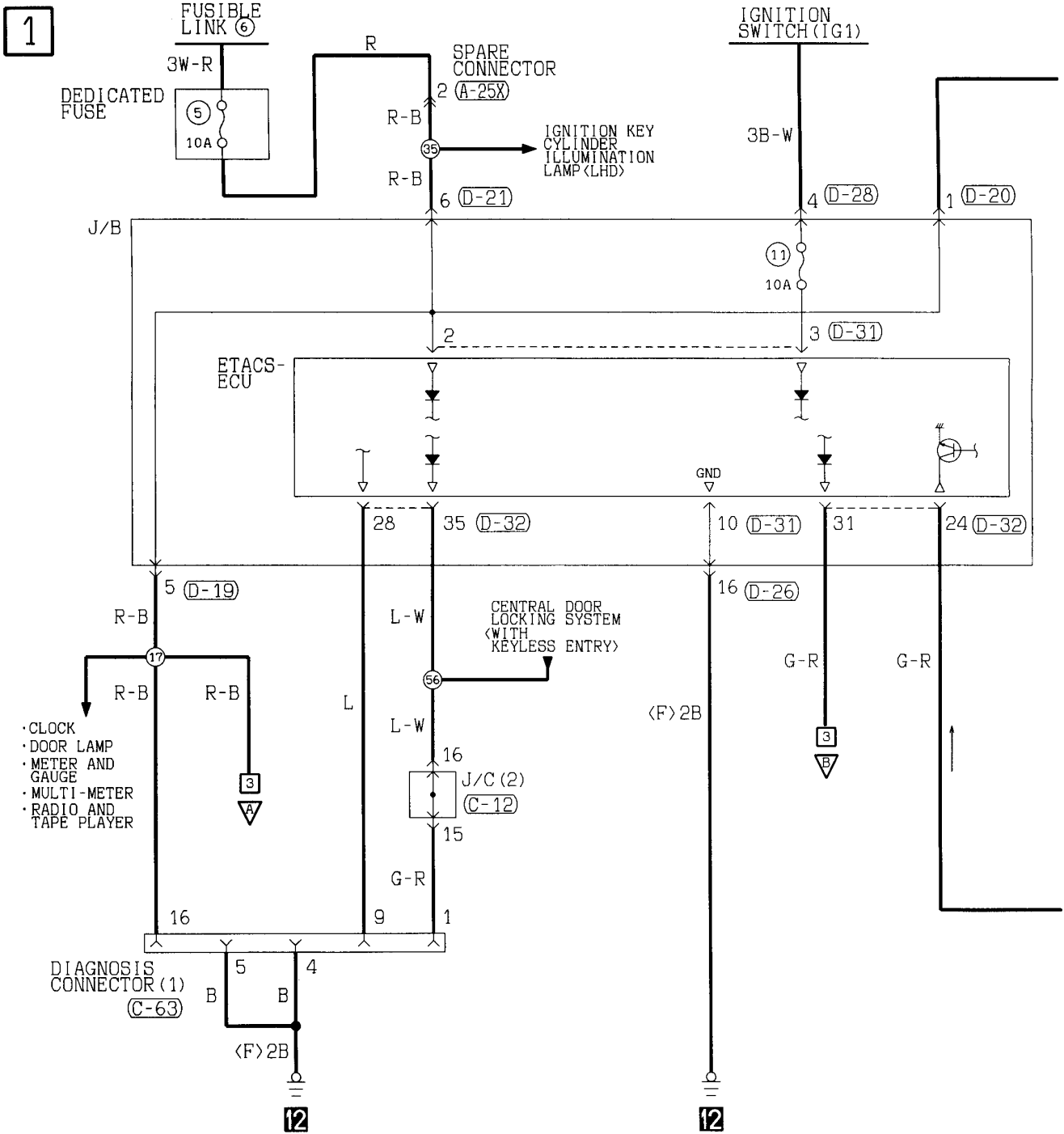

2

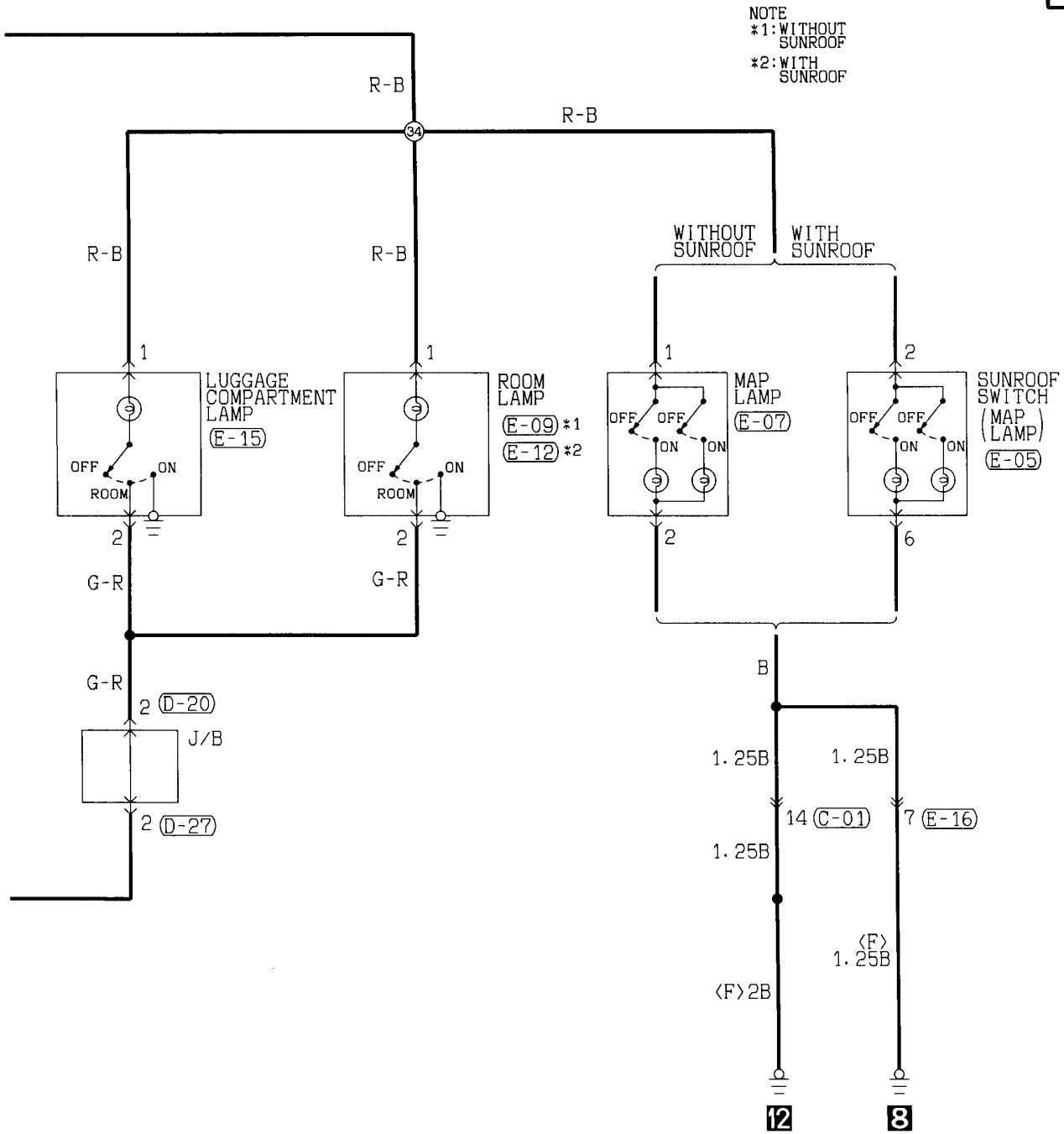

(D-26)

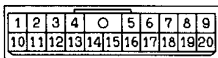

(D-27)

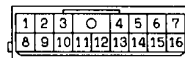

(D-28)



(D-31)

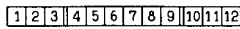

(D-32)



(E-05)



(E-07)



Wire colour code

B : Black LG: Light green G : Green L : Blue W : White Y : Yellow SB: Sky blue
 BR: Brown O : Orange GR: Gray R : Red P : Pink V : Violet

ROOM LAMP, MAP LAMP AND LUGGAGE COMPARTMENT LAMP <Vehicles with keyless entry system> (CONTINUED)

3

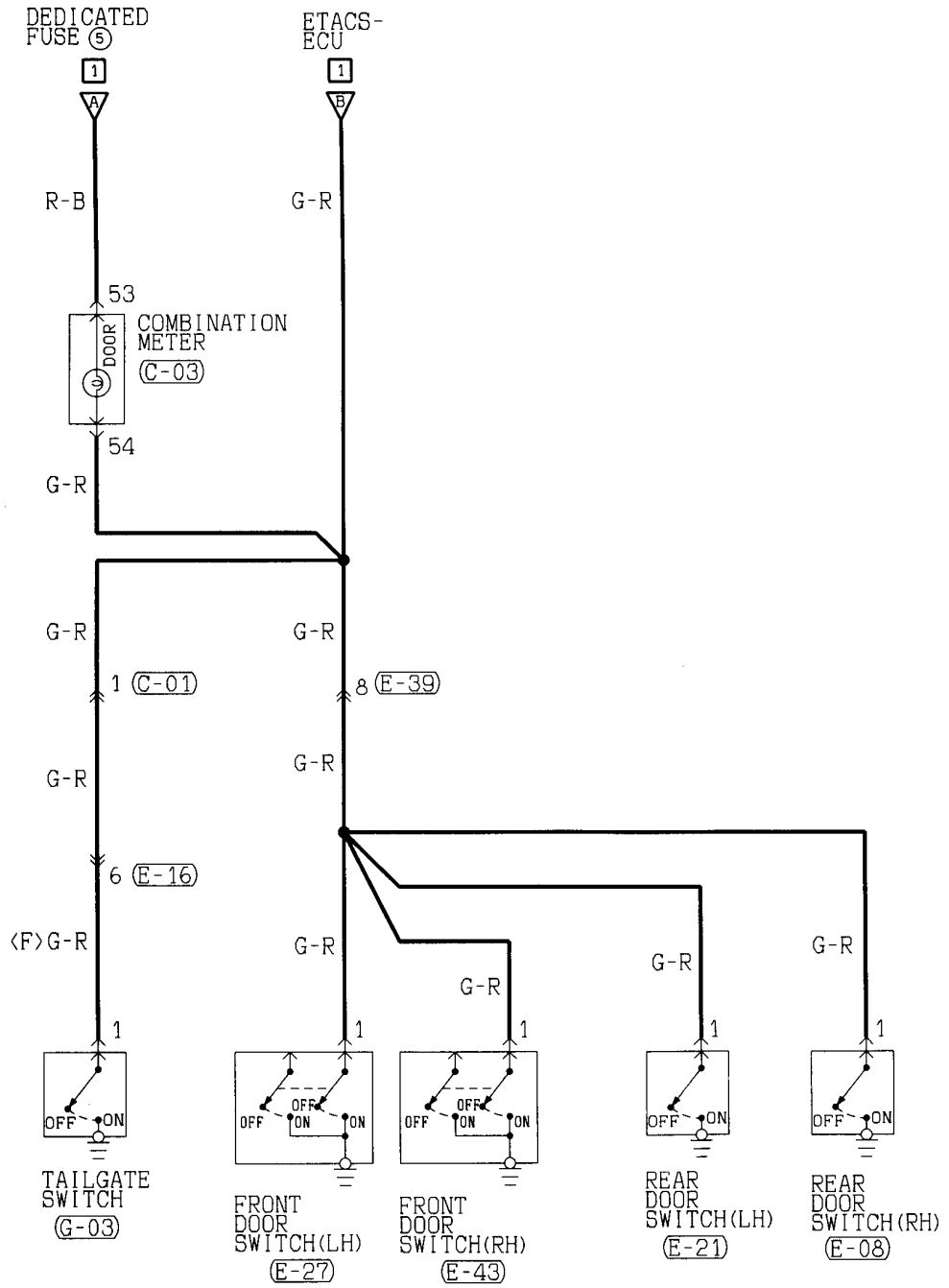

(C-01)	(C-03)	(E-08)	(E-16)	(E-21)	(E-27)	(E-39)	(E-43)																																																																																
<table border="1"> <tr><td>1</td><td>2</td><td>3</td><td>4</td><td>5</td><td>6</td><td>7</td><td>8</td><td>9</td></tr> <tr><td>10</td><td>11</td><td>12</td><td>13</td><td>14</td><td>15</td><td>16</td><td>17</td><td>18</td><td>19</td><td>20</td></tr> </table>	1	2	3	4	5	6	7	8	9	10	11	12	13	14	15	16	17	18	19	20	<table border="1"> <tr><td>5</td><td>1</td><td>2</td><td>3</td><td>4</td><td>5</td><td>6</td><td>7</td><td>8</td><td>9</td><td>10</td><td>11</td><td>12</td><td>13</td><td>14</td><td>15</td><td>16</td><td>17</td><td>18</td><td>19</td><td>20</td><td>21</td><td>22</td></tr> </table>	5	1	2	3	4	5	6	7	8	9	10	11	12	13	14	15	16	17	18	19	20	21	22	<table border="1"> <tr><td>1</td></tr> </table>	1	<table border="1"> <tr><td>1</td><td>2</td><td>3</td><td>4</td><td>5</td><td>6</td><td>7</td><td>8</td><td>9</td></tr> </table>	1	2	3	4	5	6	7	8	9	<table border="1"> <tr><td>1</td></tr> </table>	1	<table border="1"> <tr><td>1</td><td>2</td></tr> </table>	1	2	<table border="1"> <tr><td>1</td><td>2</td><td>3</td><td>4</td><td>5</td><td>6</td><td>7</td><td>8</td><td>9</td><td>10</td></tr> <tr><td>11</td><td>12</td><td>13</td><td>14</td><td>15</td><td>16</td><td>17</td><td>18</td><td>19</td><td>20</td><td>21</td><td>22</td></tr> </table>	1	2	3	4	5	6	7	8	9	10	11	12	13	14	15	16	17	18	19	20	21	22	<table border="1"> <tr><td>1</td><td>2</td></tr> </table>	1	2
1	2	3	4	5	6	7	8	9																																																																															
10	11	12	13	14	15	16	17	18	19	20																																																																													
5	1	2	3	4	5	6	7	8	9	10	11	12	13	14	15	16	17	18	19	20	21	22																																																																	
1																																																																																							
1	2	3	4	5	6	7	8	9																																																																															
1																																																																																							
1	2																																																																																						
1	2	3	4	5	6	7	8	9	10																																																																														
11	12	13	14	15	16	17	18	19	20	21	22																																																																												
1	2																																																																																						

(G-03) Wire colour code
 B : Black LG: Light green G : Green L : Blue W : White Y : Yellow SB: Sky blue
 BR: Brown O : Orange GR: Gray R : Red P : Pink V : Violet

NOTES

ROOM LAMP, MAP LAMP AND LUGGAGE COMPARTMENT LAMP

Vehicles without keyless entry system

1

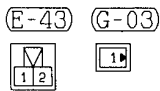
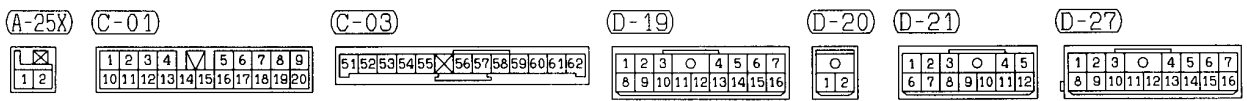
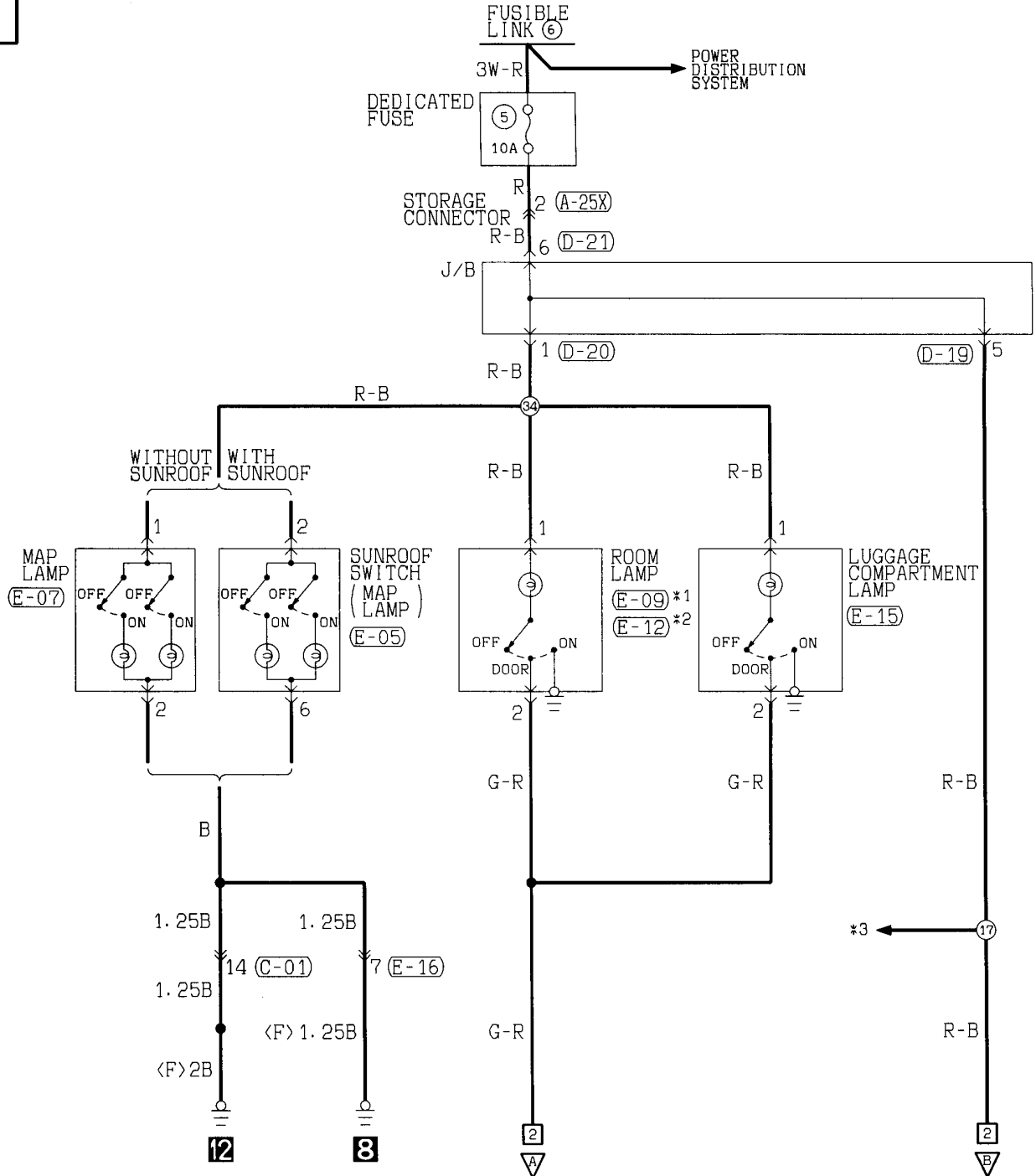

IGNITION KEY CYLINDER ILLUMINATION LAMP

L.H. drive vehicles

1

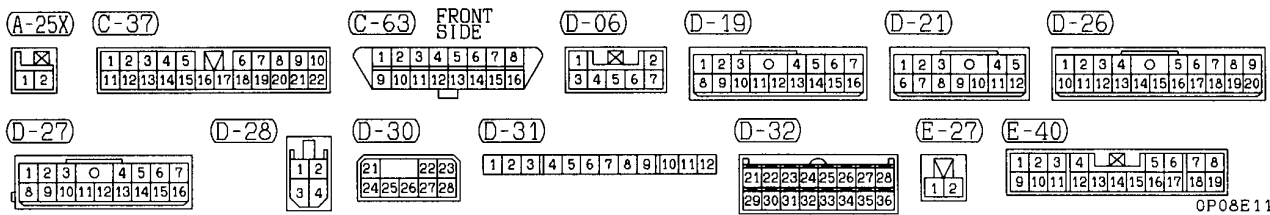
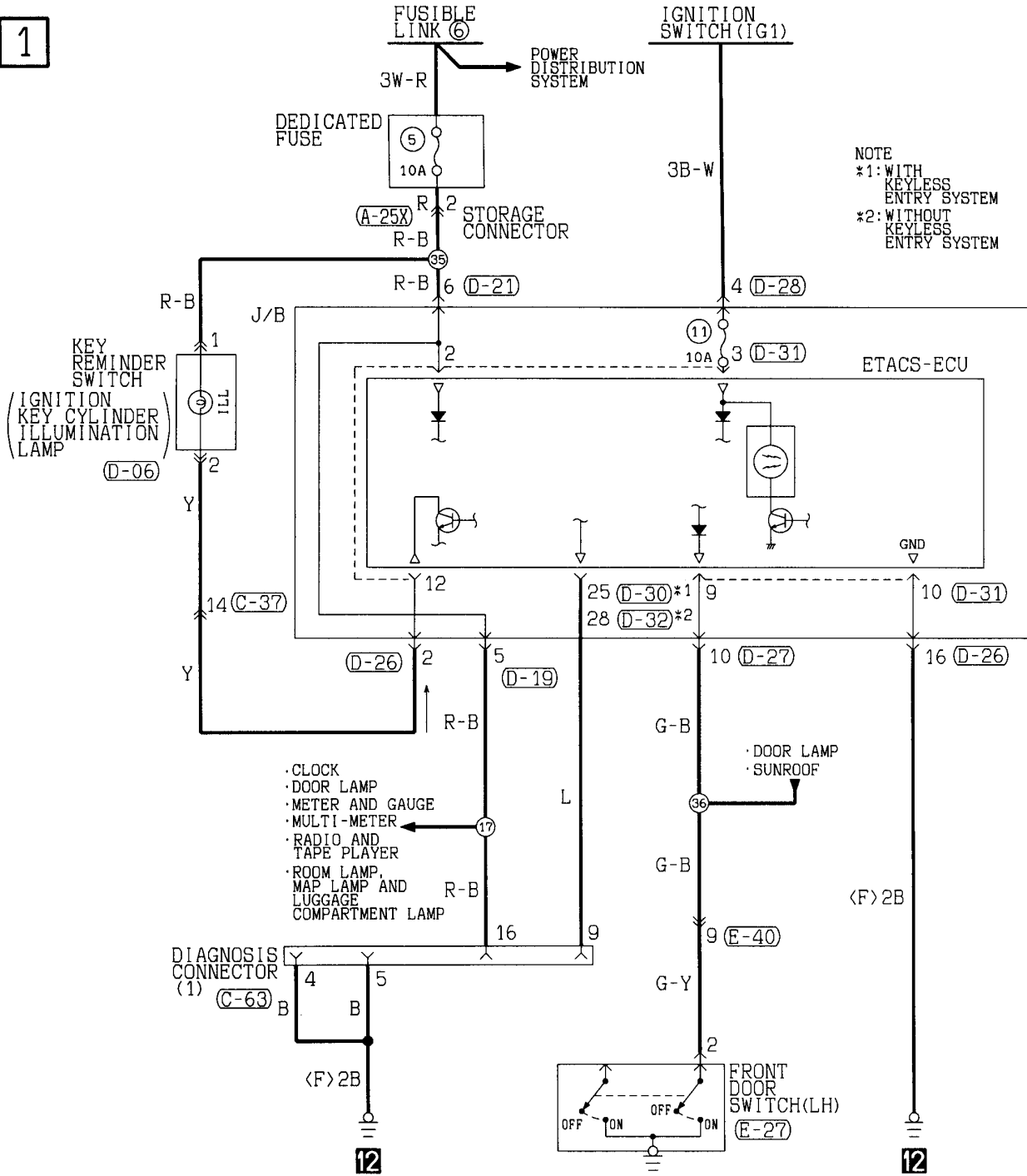

IGNITION KEY CYLINDER ILLUMINATION LAMP

R.H. drive vehicles

1

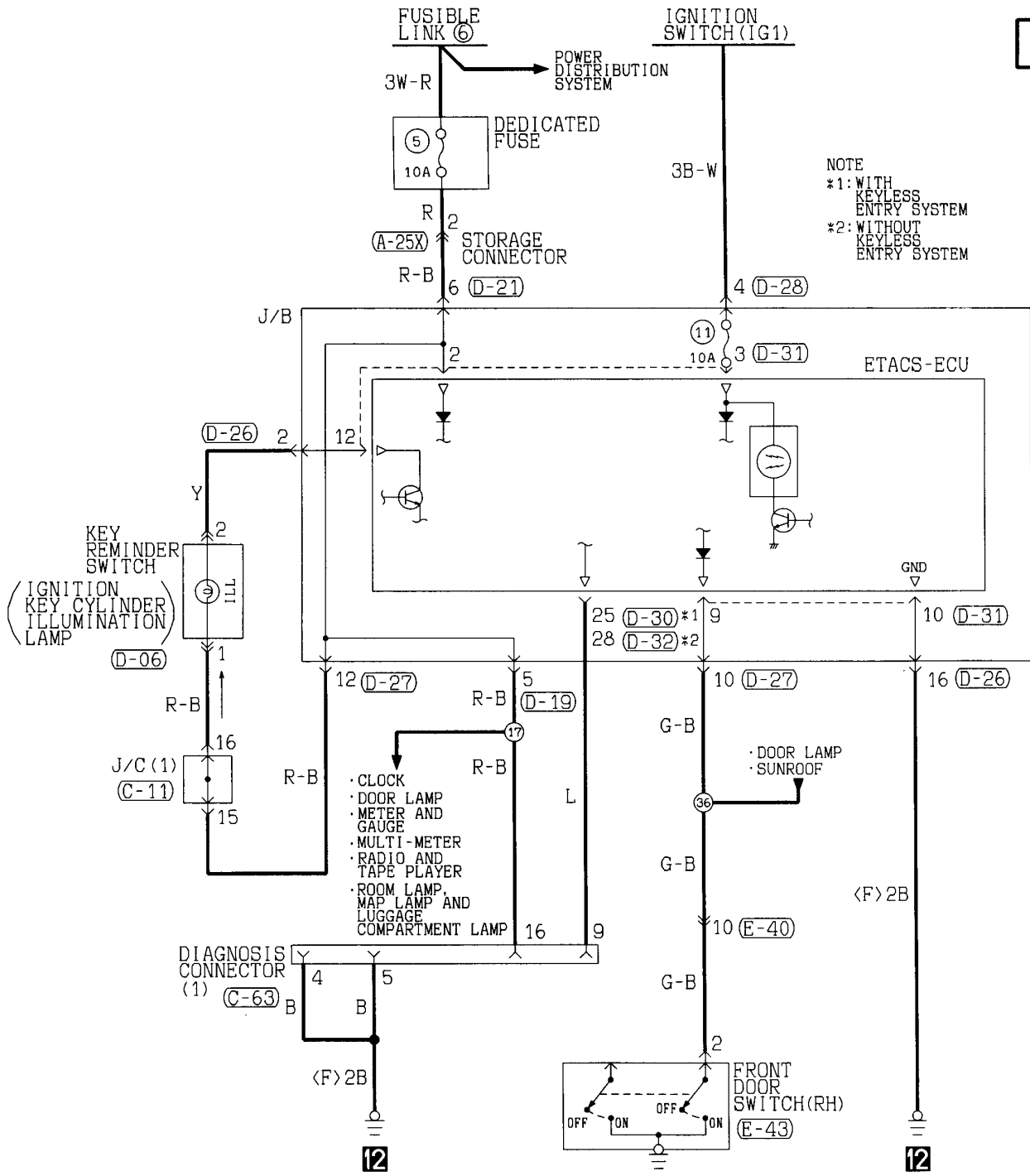

(A-25X)	(C-11)	(C-63) FRONT SIDE	(D-06)	(D-19)	(D-21)	(D-26)
(D-27)	(D-28)	(D-30)	(D-31)	(D-32)	(E-40)	(E-43)

DOOR LAMP

L.H. drive vehicles

1

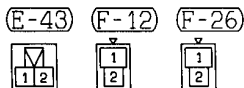
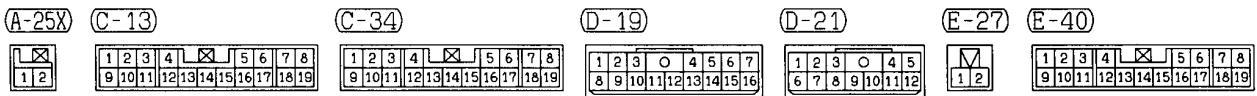
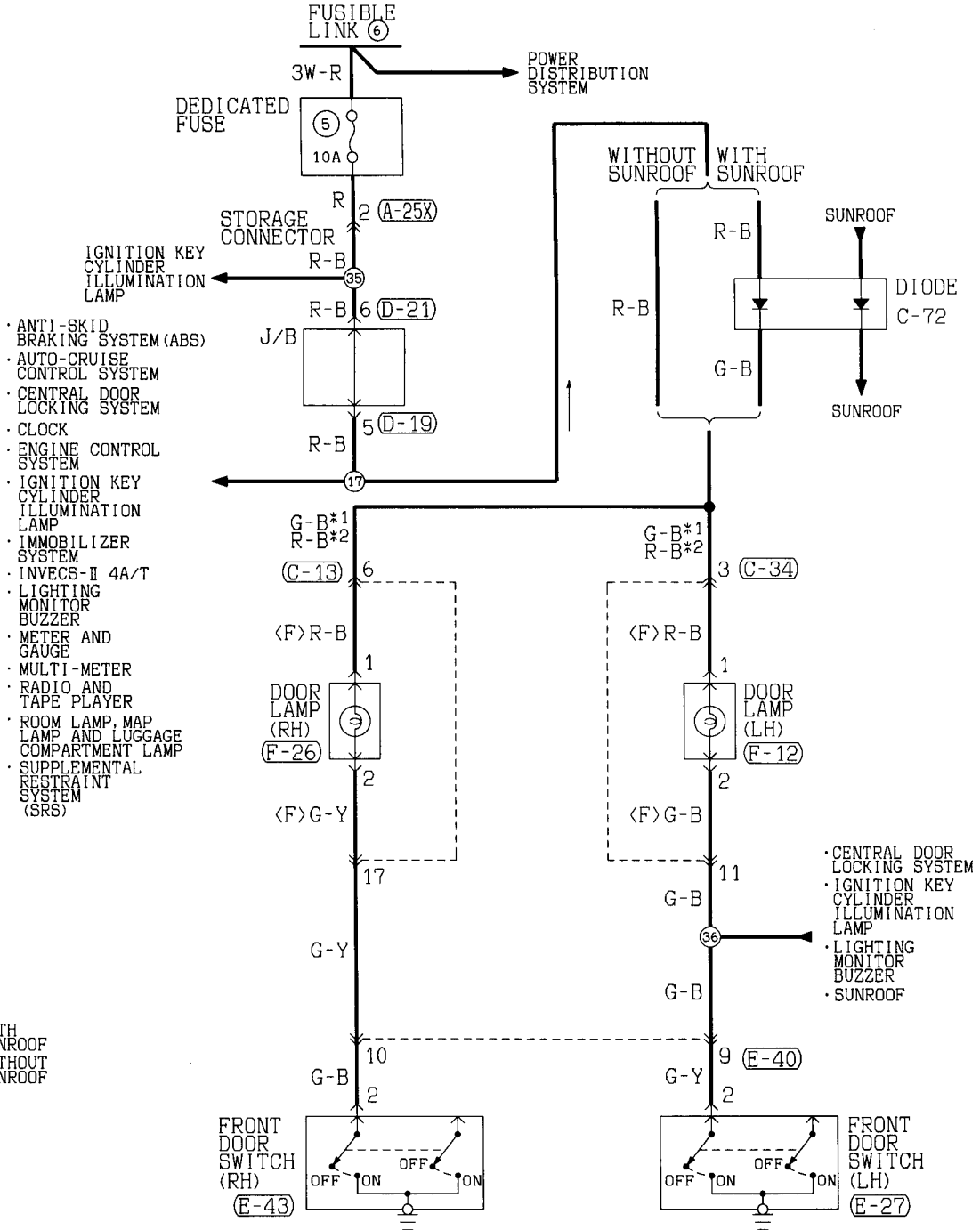

Wire colour code
 B : Black LG : Light green G : Green L : Blue
 BR : Brown O : Orange GR : Gray R : Red
 W : White SB : Sky blue P : Pink Y : Yellow
 V : Violet

DOOR LAMP

R.H. drive vehicles

1

- ANTI-SKID BRAKING SYSTEM (ABS)
- AUTO-CRUISE CONTROL SYSTEM
- CENTRAL DOOR LOCKING SYSTEM
- CLOCK
- ENGINE CONTROL SYSTEM
- IGNITION KEY CYLINDER ILLUMINATION LAMP
- IMMOBILIZER SYSTEM
- INVECS-II 4A/T
- LIGHTING MONITOR BUZZER
- METER AND GAUGE
- MULTI-METER
- RADIO AND TAPE PLAYER
- ROOM LAMP, MAP LAMP AND LUGGAGE COMPARTMENT LAMP
- SUPPLEMENTAL RESTRAINT SYSTEM (SRS)

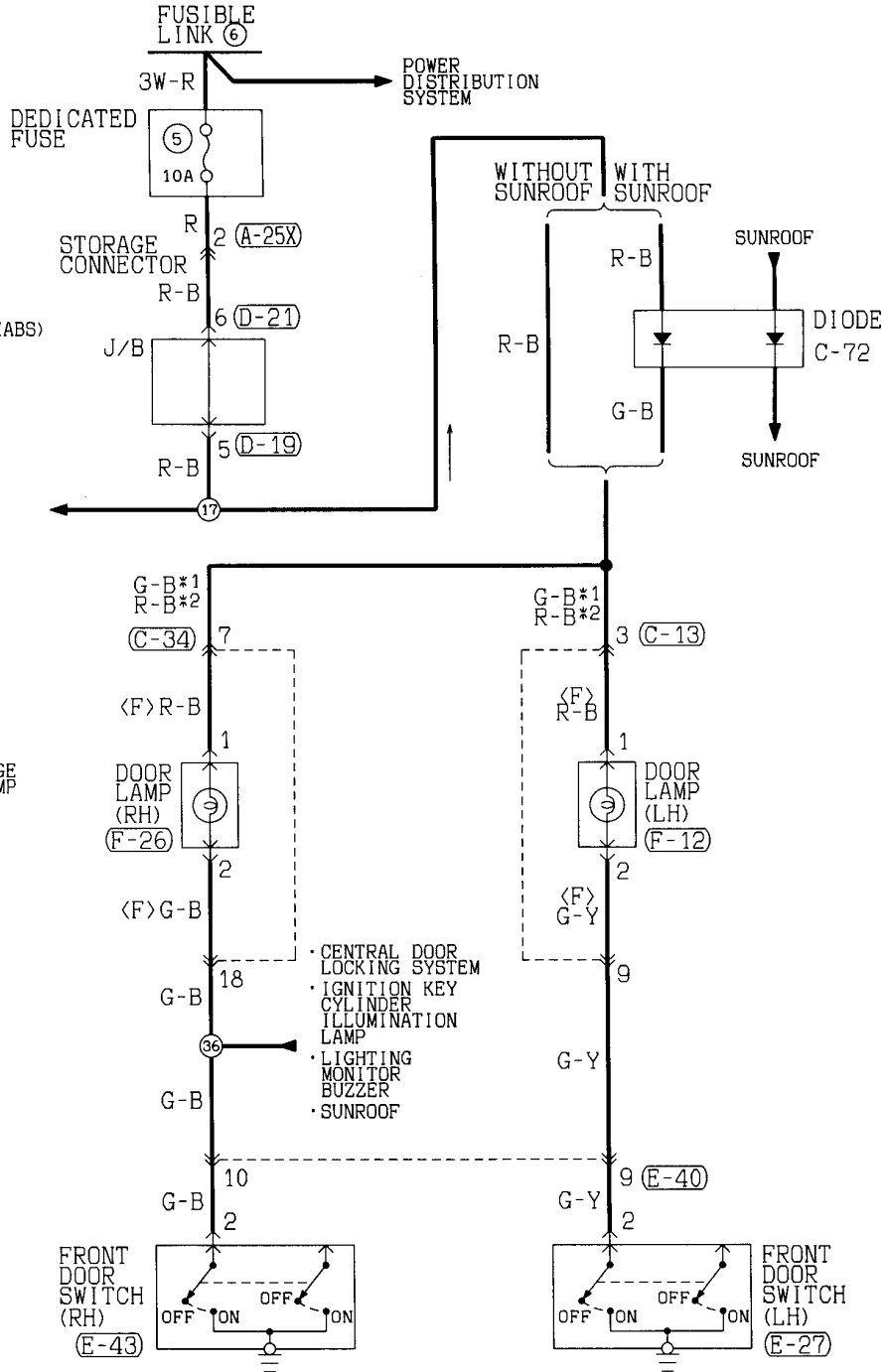

NOTE
 *1: WITH SUNROOF
 *2: WITHOUT SUNROOF

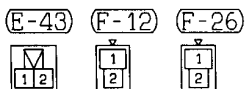
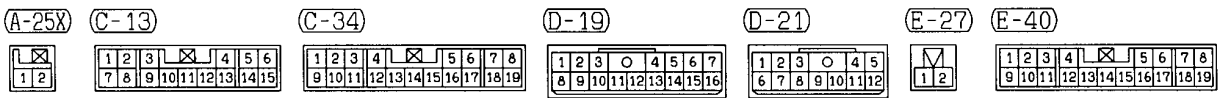

Wire colour code
 B : Black LG: Light green G : Green L : Blue
 BR: Brown O : Orange GR: Gray R : Red
 W : White SB: Sky blue P : Pink Y : Yellow
 V : Violet

TURN-SIGNAL LAMP AND HAZARD WARNING LAMP

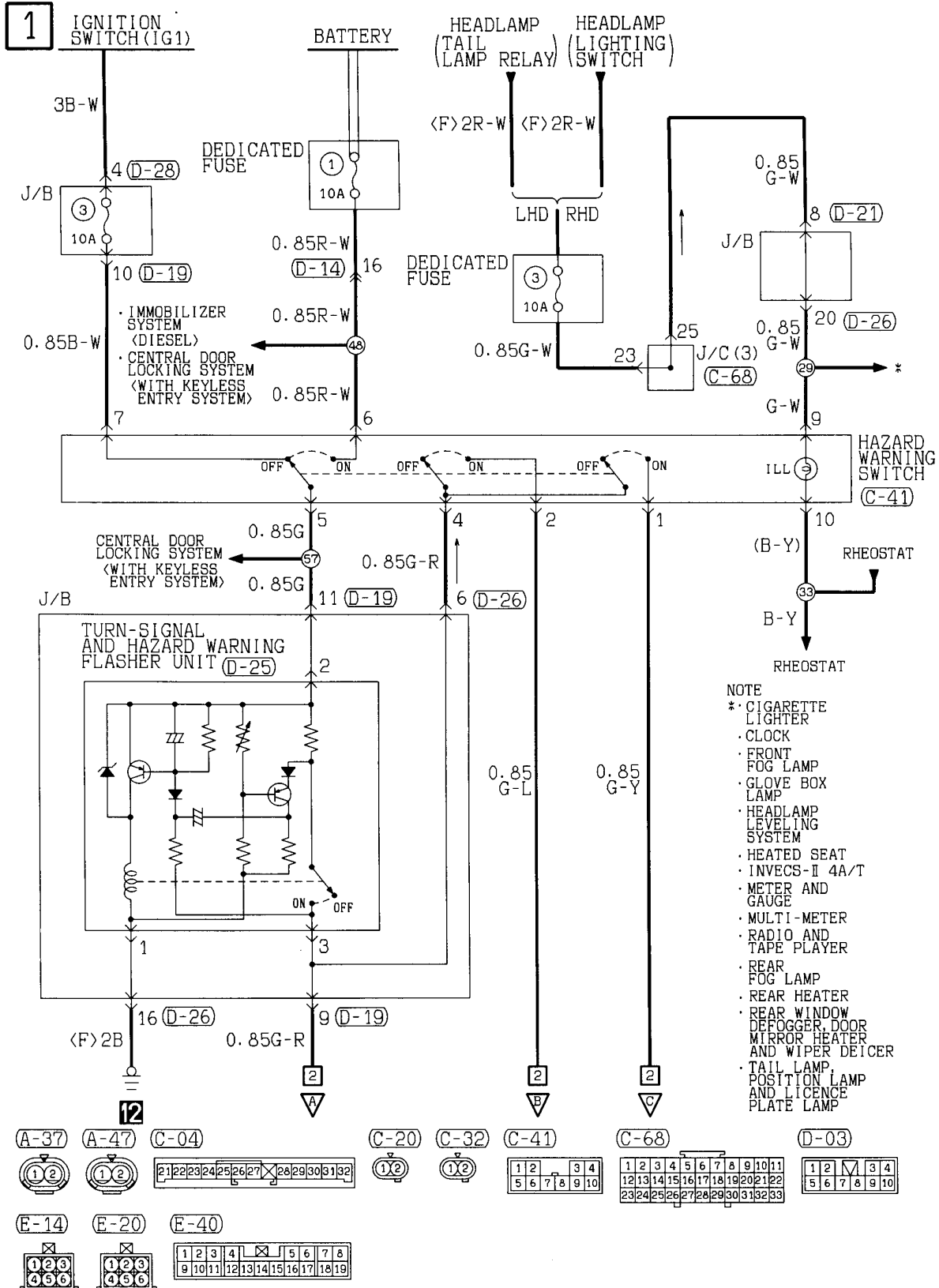

2

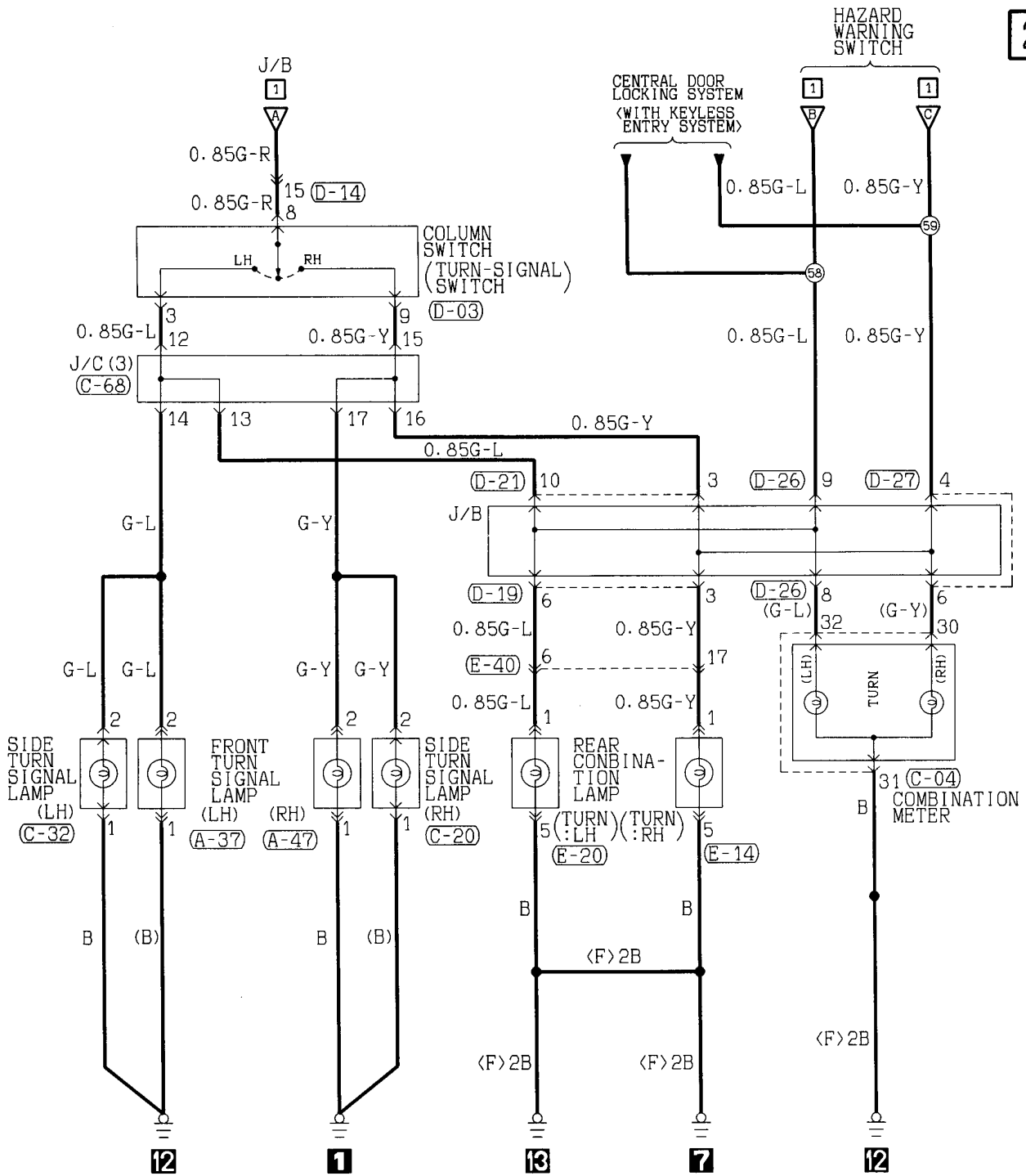

D-14	D-19	D-21	D-25	D-26	D-27	D-28																																																																																																																																		
<table border="1"> <tr><td>1</td><td>2</td><td>3</td><td>4</td><td>5</td><td>6</td><td>7</td><td>8</td></tr> <tr><td>9</td><td>10</td><td>11</td><td>12</td><td>13</td><td>14</td><td>15</td><td>16</td></tr> <tr><td>17</td><td>18</td><td>19</td><td></td><td></td><td></td><td></td><td></td></tr> </table>	1	2	3	4	5	6	7	8	9	10	11	12	13	14	15	16	17	18	19						<table border="1"> <tr><td>1</td><td>2</td><td>3</td><td>4</td><td>5</td><td>6</td><td>7</td></tr> <tr><td>8</td><td>9</td><td>10</td><td>11</td><td>12</td><td>13</td><td>14</td></tr> <tr><td>15</td><td>16</td><td></td><td></td><td></td><td></td><td></td></tr> </table>	1	2	3	4	5	6	7	8	9	10	11	12	13	14	15	16						<table border="1"> <tr><td>1</td><td>2</td><td>3</td><td>4</td><td>5</td></tr> <tr><td>6</td><td>7</td><td>8</td><td>9</td><td>10</td></tr> <tr><td>11</td><td>12</td><td></td><td></td><td></td></tr> </table>	1	2	3	4	5	6	7	8	9	10	11	12				<table border="1"> <tr><td>1</td><td>2</td><td>3</td><td>4</td><td>5</td><td>6</td><td>7</td><td>8</td></tr> <tr><td>9</td><td>10</td><td>11</td><td>12</td><td>13</td><td>14</td><td>15</td><td>16</td></tr> <tr><td>17</td><td>18</td><td>19</td><td>20</td><td></td><td></td><td></td><td></td></tr> </table>	1	2	3	4	5	6	7	8	9	10	11	12	13	14	15	16	17	18	19	20					<table border="1"> <tr><td>1</td><td>2</td><td>3</td><td>4</td><td>5</td><td>6</td><td>7</td></tr> <tr><td>8</td><td>9</td><td>10</td><td>11</td><td>12</td><td>13</td><td>14</td></tr> <tr><td>15</td><td>16</td><td></td><td></td><td></td><td></td><td></td></tr> </table>	1	2	3	4	5	6	7	8	9	10	11	12	13	14	15	16						<table border="1"> <tr><td>1</td><td>2</td><td>3</td><td>4</td><td>5</td><td>6</td><td>7</td></tr> <tr><td>8</td><td>9</td><td>10</td><td>11</td><td>12</td><td>13</td><td>14</td></tr> <tr><td>15</td><td>16</td><td></td><td></td><td></td><td></td><td></td></tr> </table>	1	2	3	4	5	6	7	8	9	10	11	12	13	14	15	16						<table border="1"> <tr><td>1</td><td>2</td></tr> <tr><td>3</td><td>4</td></tr> </table>	1	2	3	4
1	2	3	4	5	6	7	8																																																																																																																																	
9	10	11	12	13	14	15	16																																																																																																																																	
17	18	19																																																																																																																																						
1	2	3	4	5	6	7																																																																																																																																		
8	9	10	11	12	13	14																																																																																																																																		
15	16																																																																																																																																							
1	2	3	4	5																																																																																																																																				
6	7	8	9	10																																																																																																																																				
11	12																																																																																																																																							
1	2	3	4	5	6	7	8																																																																																																																																	
9	10	11	12	13	14	15	16																																																																																																																																	
17	18	19	20																																																																																																																																					
1	2	3	4	5	6	7																																																																																																																																		
8	9	10	11	12	13	14																																																																																																																																		
15	16																																																																																																																																							
1	2	3	4	5	6	7																																																																																																																																		
8	9	10	11	12	13	14																																																																																																																																		
15	16																																																																																																																																							
1	2																																																																																																																																							
3	4																																																																																																																																							

Wire colour code
 B : Black LG : Light green G : Green L : Blue W : White Y : Yellow SB : Sky blue
 BR : Brown O : Orange GR : Gray R : Red P : Pink V : Violet

STOP LAMP

1

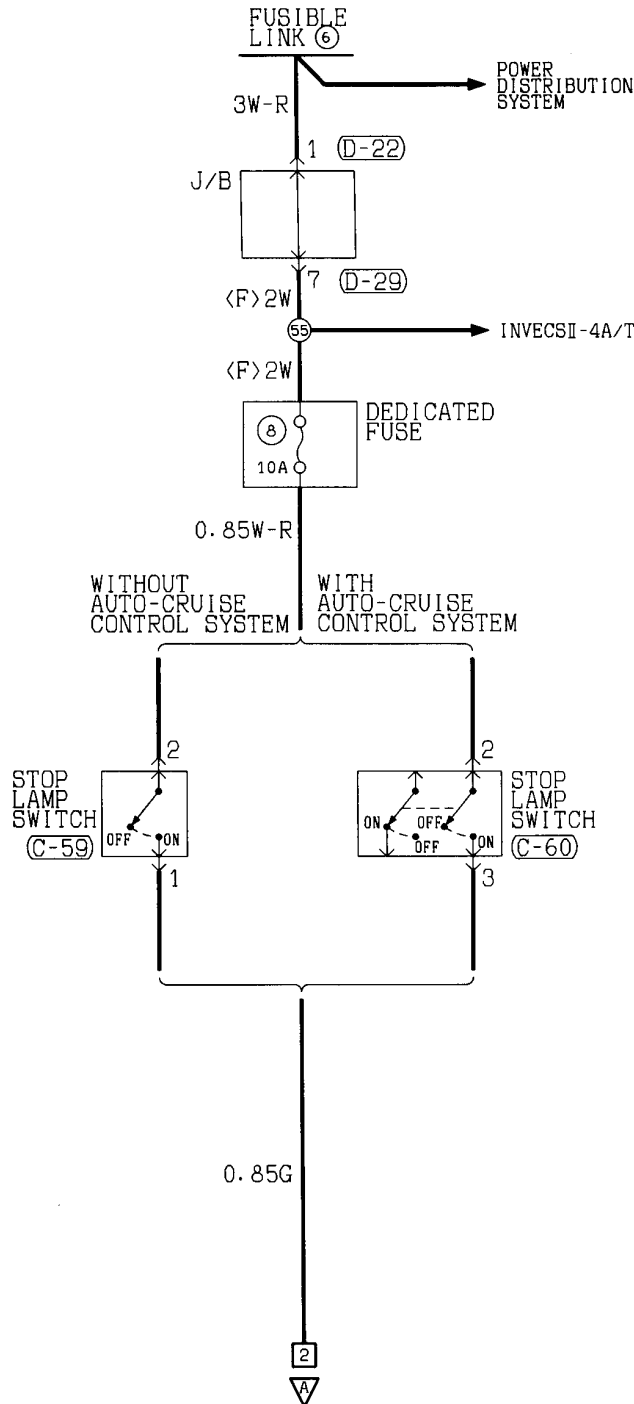

C-01

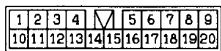

C-59



C-60



D-22



D-29



E-14



E-16

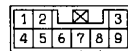

E-20



E-40

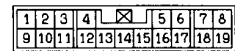

G-01



2

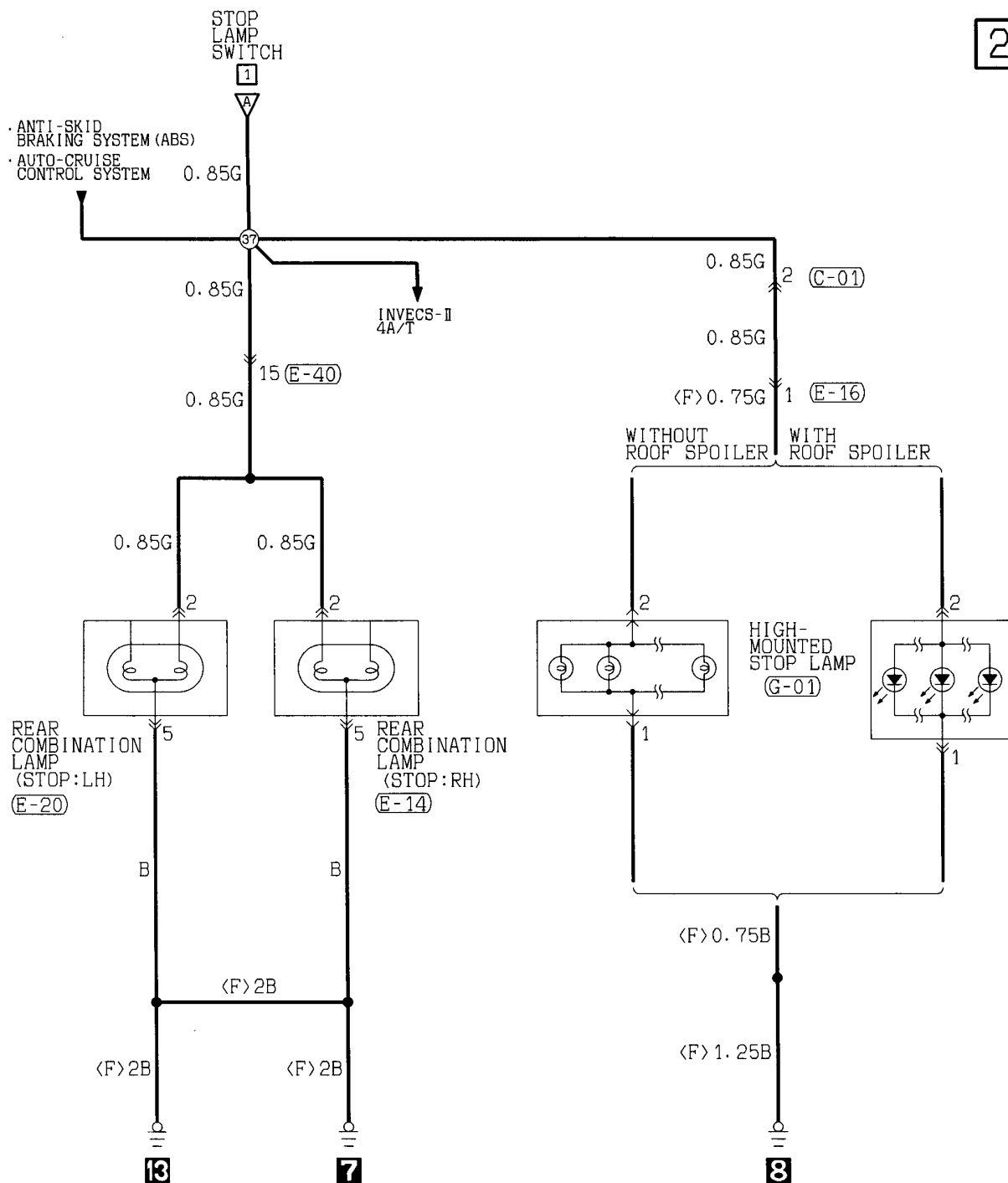

Wire colour code
 B : Black LG: Light green G : Green L : Blue W : White Y : Yellow SB: Sky blue
 BR: Brown O : Orange GR: Gray R : Red P : Pink V : Violet

BACK-UP LAMP

1

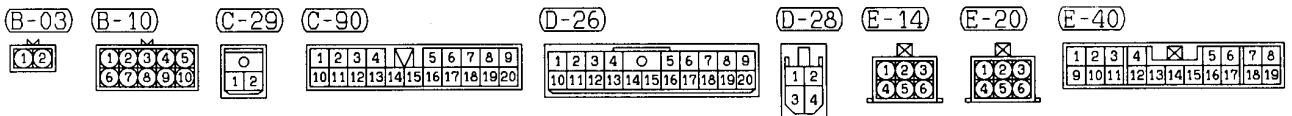
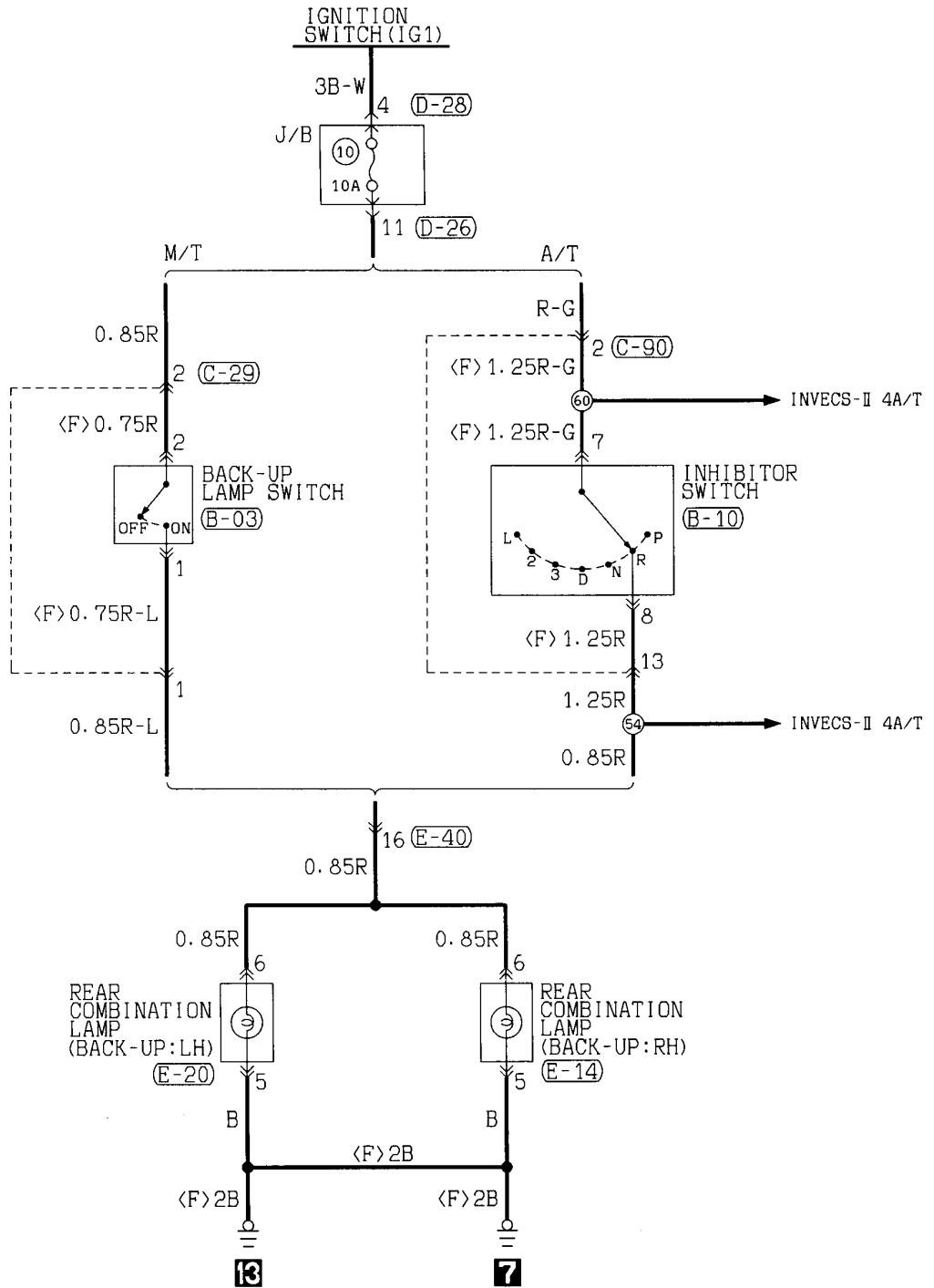

Wire colour code
 B : Black LG: Light green G : Green L : Blue W : White Y : Yellow SB: Sky blue
 BR: Brown O : Orange GR: Gray R : Red P : Pink V : Violet

HORN

1

NOTE
 *1: WITHOUT AUTO-CRUISE CONTROL SYSTEM
 *2: WITH AUTO-CRUISE CONTROL SYSTEM

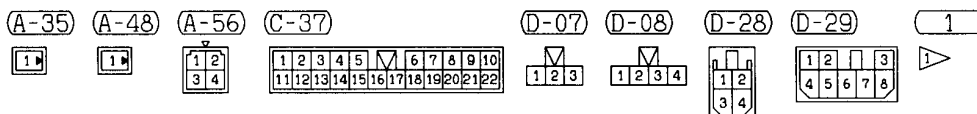
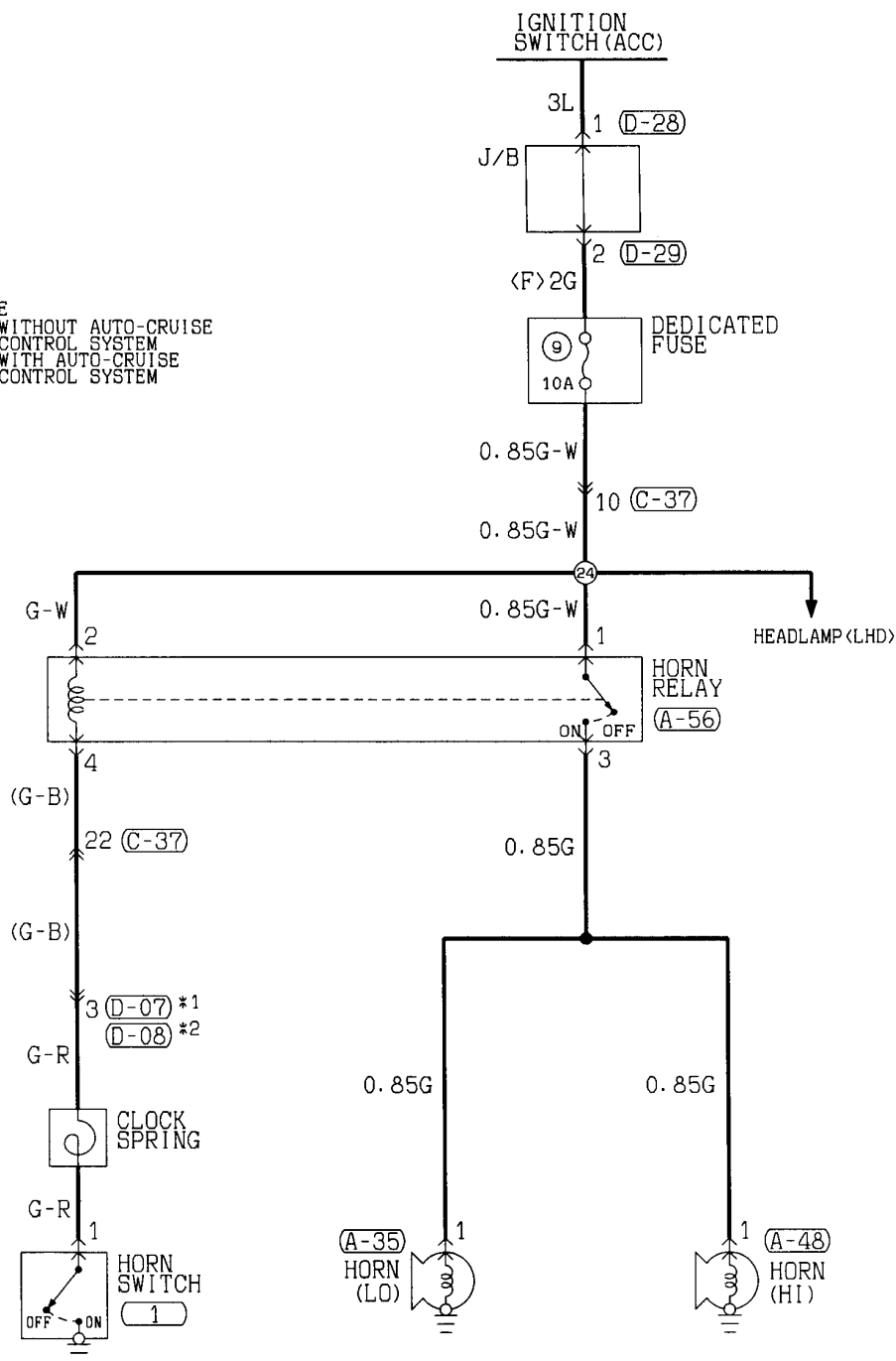

Wire colour code
 B :Black LG:Light green G :Green L :Blue W :White Y :Yellow SB:Sky blue
 BR:Brown O :Orange GR:Gray R :Red P :Pink V :Violet

METER AND GAUGE

1

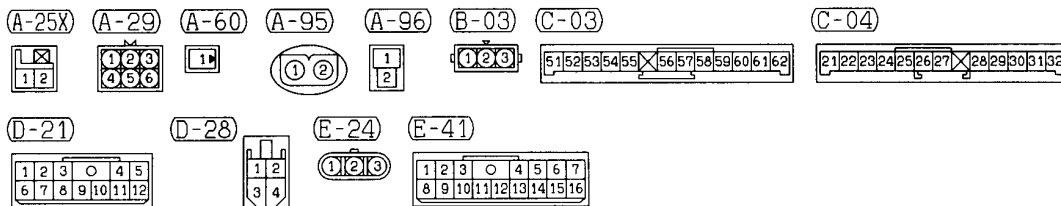
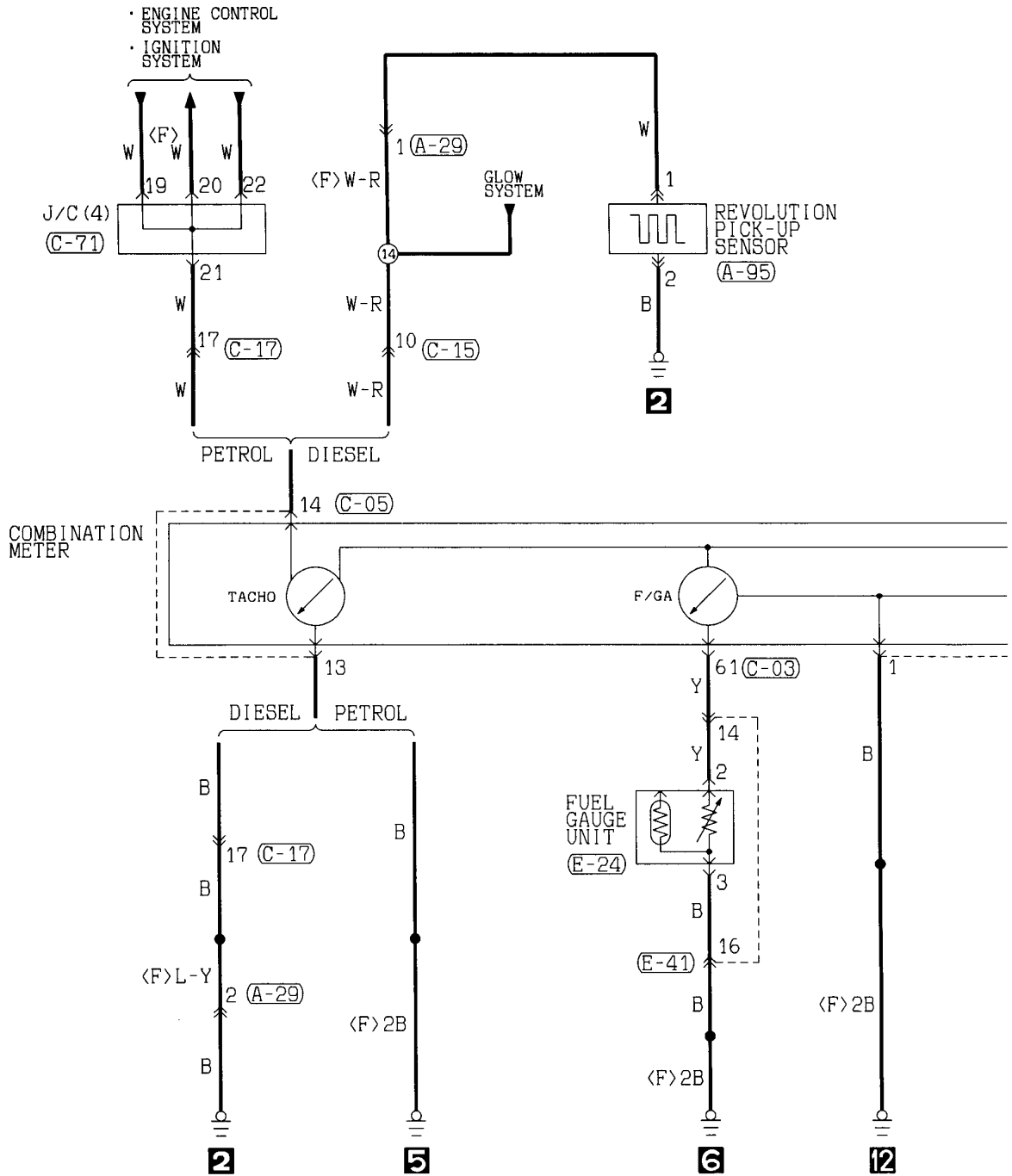

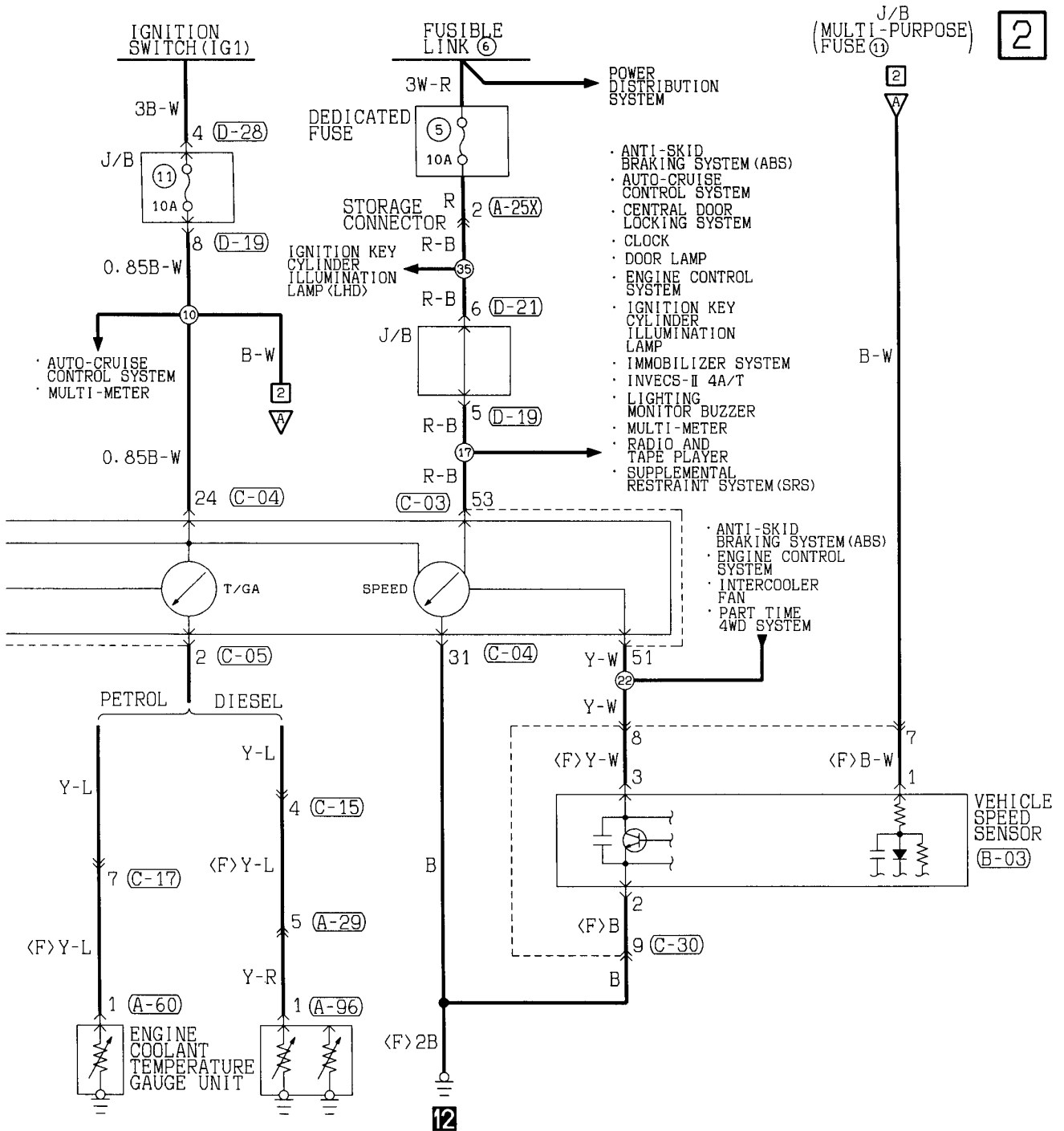

(C-05)

1	2	3	4	5	6	7	8	9	10	11	12	13	14
---	---	---	---	---	---	---	---	---	----	----	----	----	----

(C-15)

1	2	3	0	4	5	
6	7	8	9	10	11	12

(C-17)

1	2	3	4	5	6	7	8	9	10		
11	12	13	14	15	16	17	18	19	20	21	22

(C-30)

1	2	3			
4	5	6	7	8	9

(C-71)

1	2	3	4	5	6	7	8	9	10	11
12	13	14	15	16	17	18	19	20	21	22
23	24	25	26	27	28	29	30	31	32	33

(D-19)

1	2	3	0	4	5	6	7	
8	9	10	11	12	13	14	15	16

Wire colour code
 B : Black LG:Light green G :Green L :Blue W :White Y :Yellow SB:Sky blue
 BR:Brown O :Orange GR:Gray R :Red P :Pink V :Violet

METER AND GAUGE (CONTINUED)

3

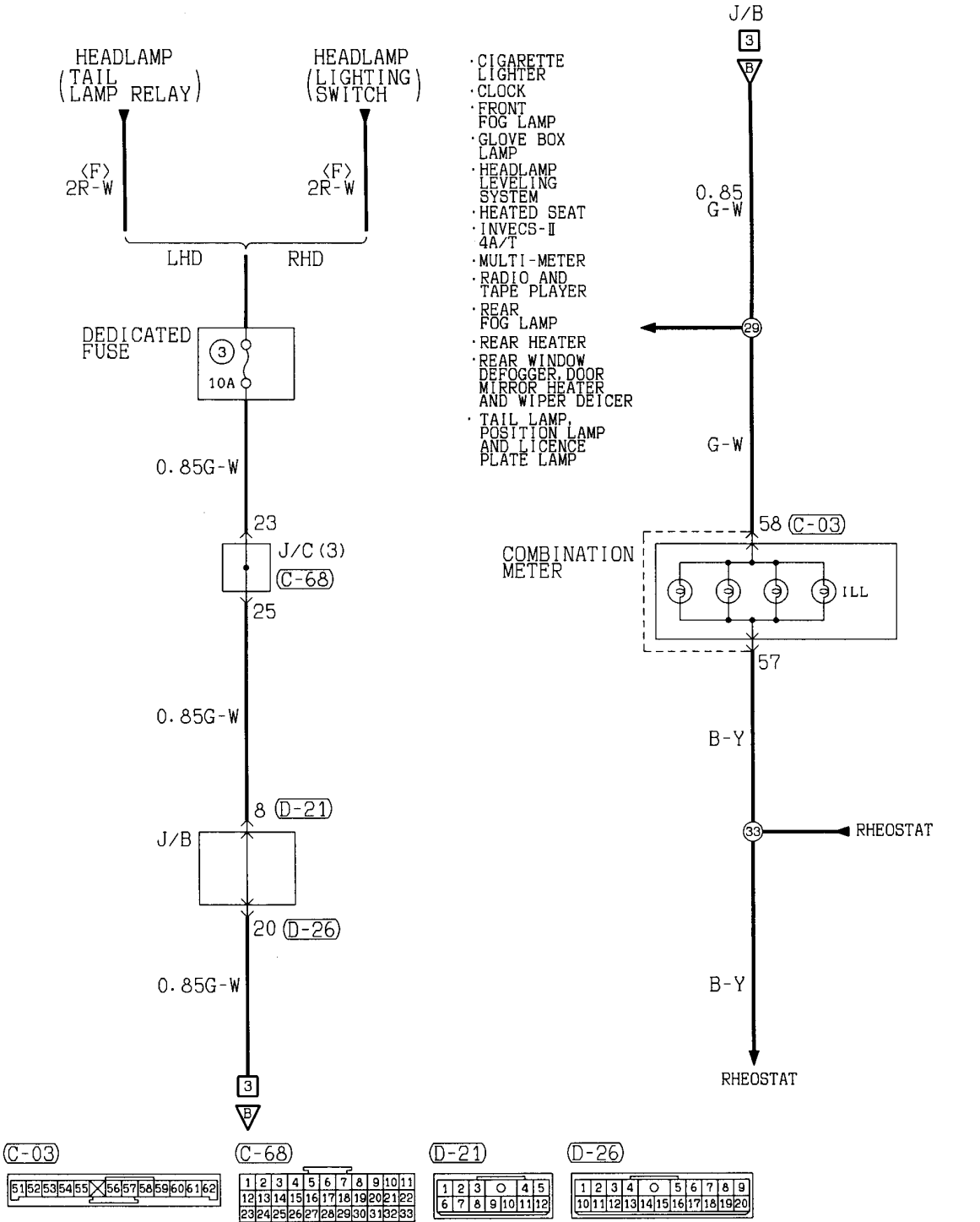

Wire colour code
 B : Black LG : Light green G : Green L : Blue W : White Y : Yellow SB : Sky blue
 BR : Brown O : Orange GR : Gray R : Red P : Pink V : Violet

NOTES

BRAKE WARNING LAMP FUEL WARNING LAMP

1

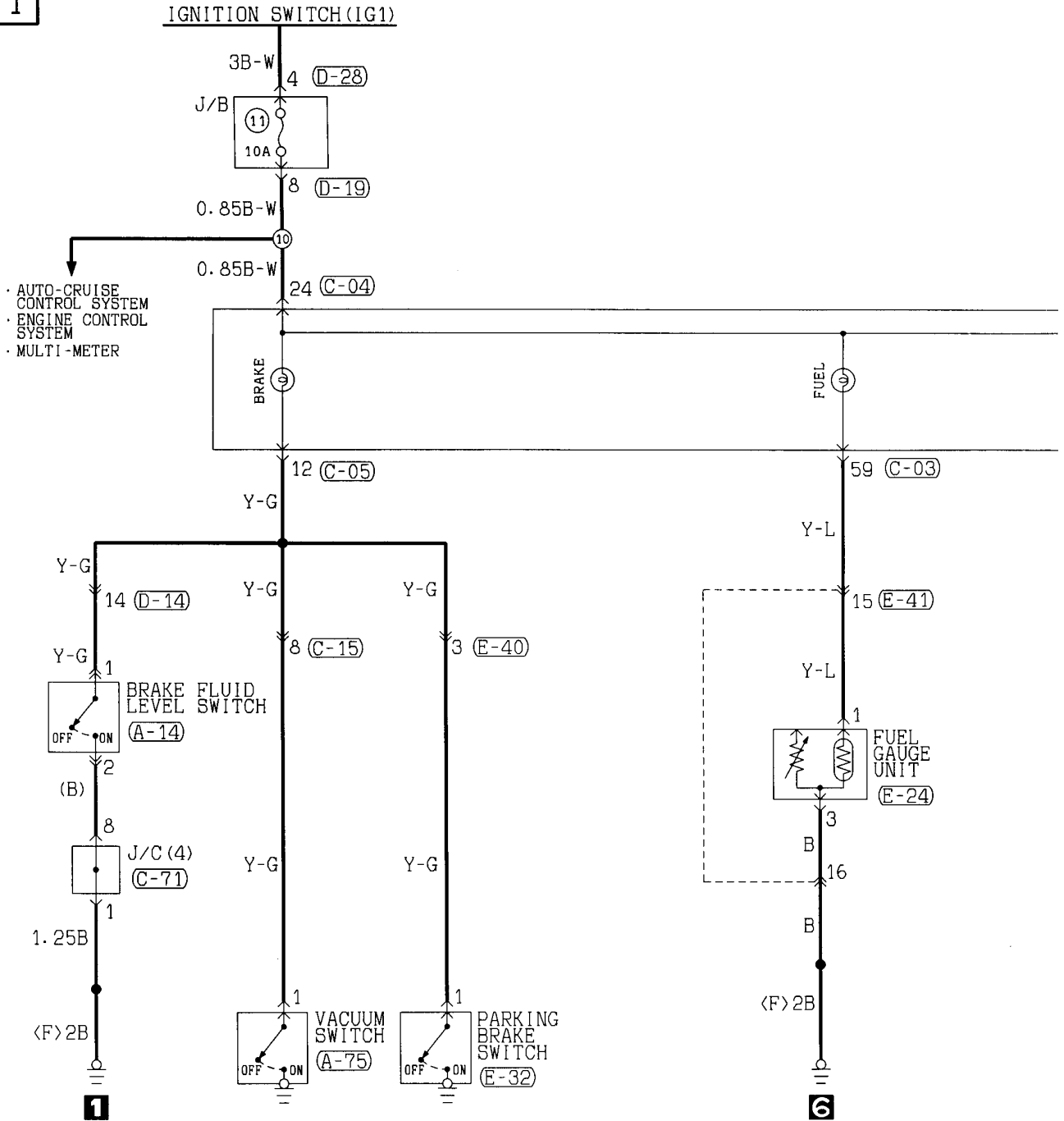

(A-14)	(A-40)	(A-73)	(A-75)	(A-86)	(C-03)	(C-04)	(C-05)
1 2	1	1 2	1	1 2 3 4 5 6	5 1 5 2 5 3 5 4 5 5 5 6 5 7 5 8 5 9 6 0 6 1 6 2	2 1 2 2 2 3 2 4 2 5 2 6 2 7 2 8 2 9 3 0 3 1 3 2	1 2 3 4 5 6 7 8 9 1 0 1 1 1 2 1 3 1 4
(D-19)	(D-28)		(E-24)	(E-32)	(E-40)	(E-41)	
1 2 3 4 5 6 7 8 9 1 0 1 1 1 2 1 3 1 4 1 5 1 6	1 2 3 4		1 2 3	1	1 2 3 4 5 6 7 8 9 1 0 1 1 1 2 1 3 1 4 1 5 1 6 1 7 1 8 1 9	1 2 3 4 5 6 7 8 9 1 0 1 1 1 2 1 3 1 4 1 5 1 6	

**OIL PRESSURE WARNING LAMP
FUEL FILTER WARNING LAMP**
Diesel-powered vehicles

2

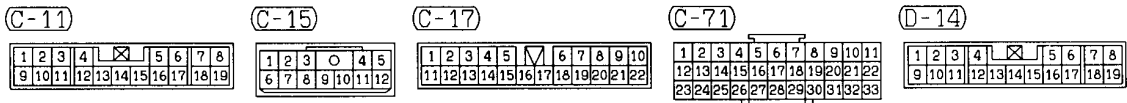
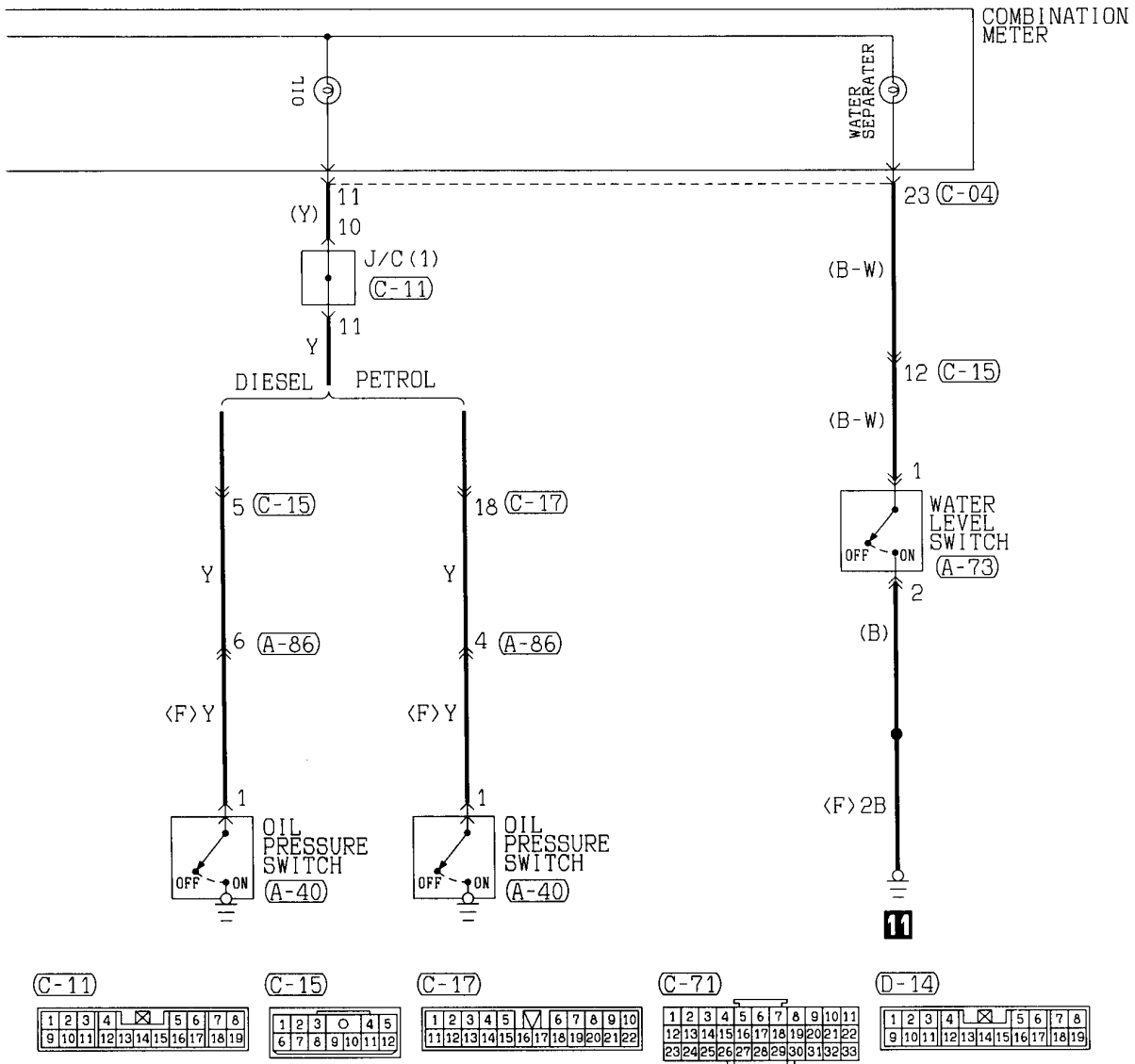

Wire colour code
 B :Black LG:Light green G :Green L :Blue W :White Y :Yellow SB:Sky blue
 BR:Brown O :Orange GR:Gray R :Red P :Pink V :Violet

CENTRAL DOOR LOCKING SYSTEM

L.H. drive vehicles with keyless entry system

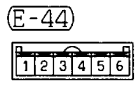
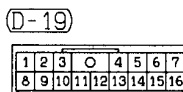
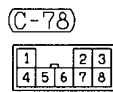
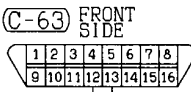
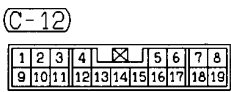
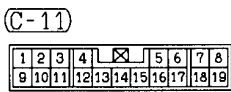
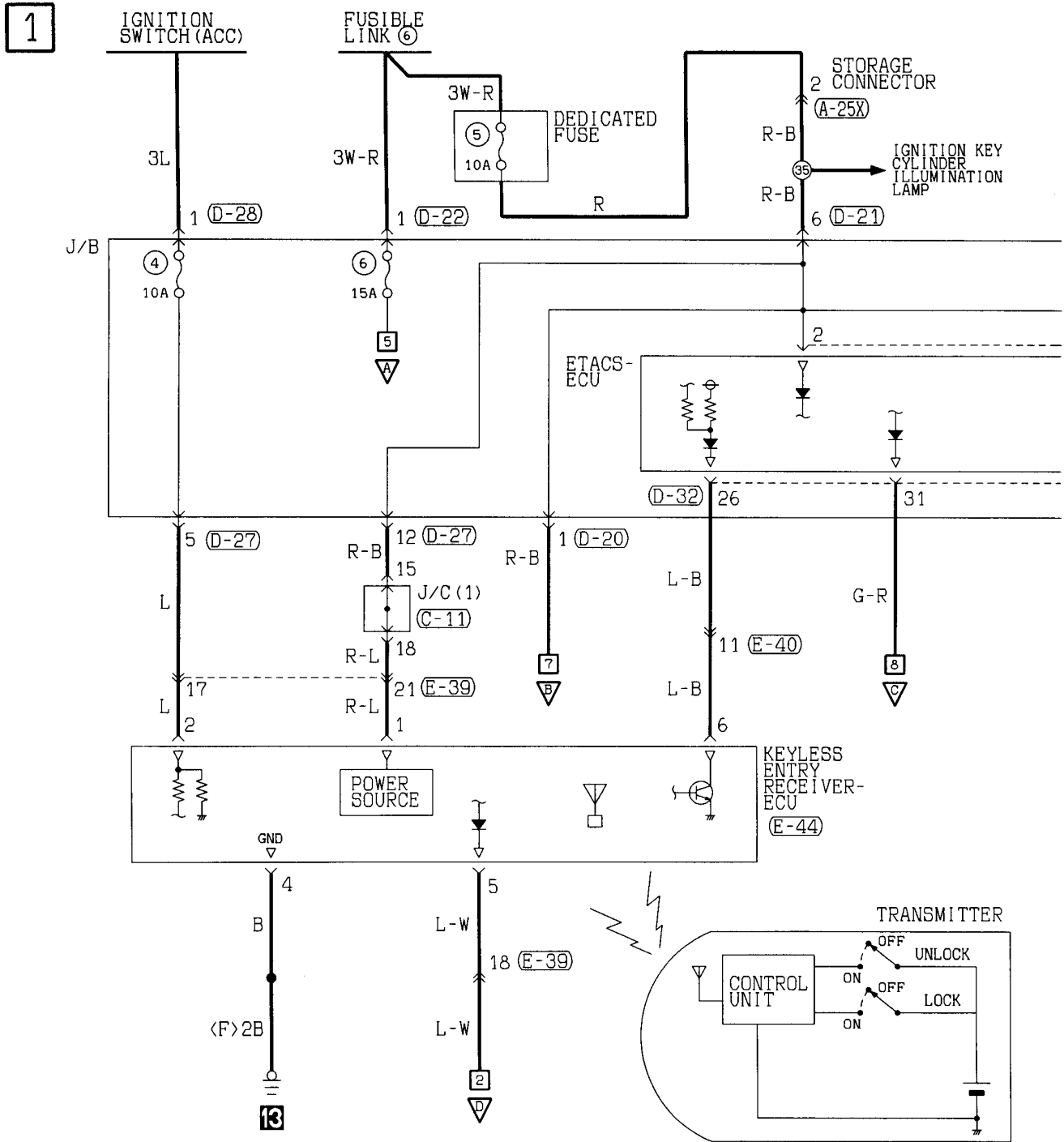

2

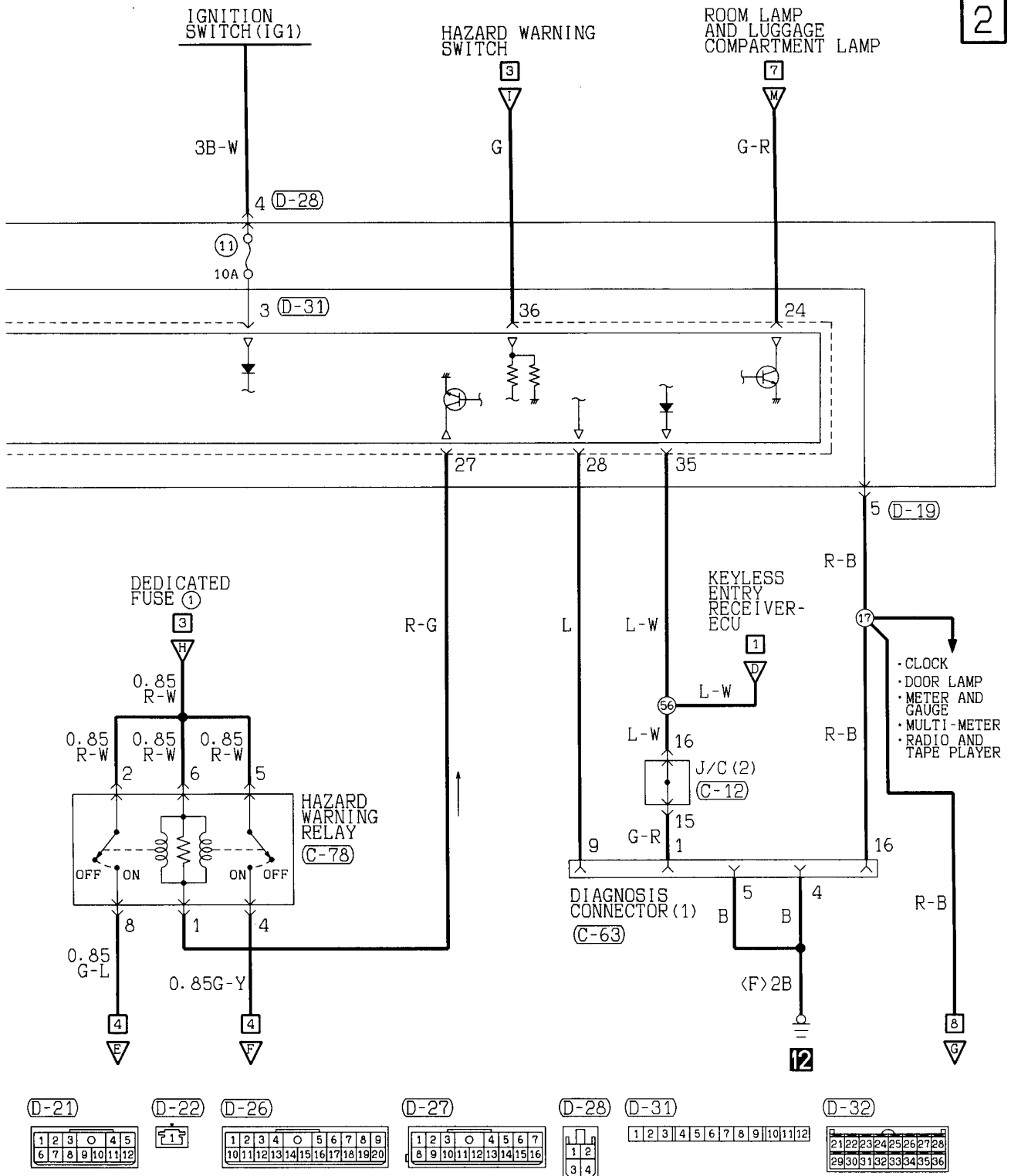

Wire colour code
 B : Black LG:Light green G : Green L : Blue W : White Y : Yellow SB:Sky blue
 BR:Brown O : Orange GR:Gray R : Red P : Pink V : Violet

CENTRAL DOOR LOCKING SYSTEM <L.H. drive vehicles with keyless entry system> (CONTINUED)

3

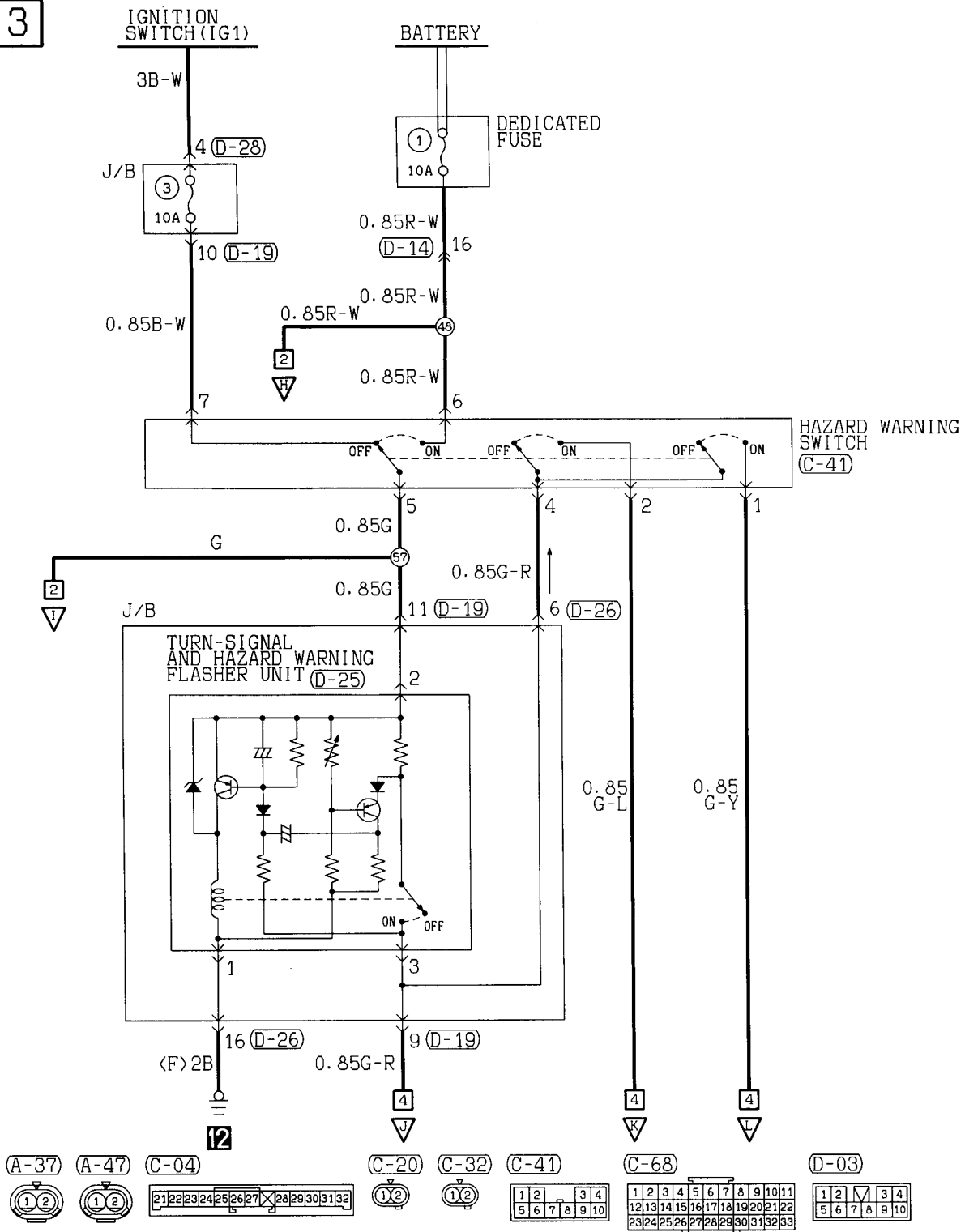

4

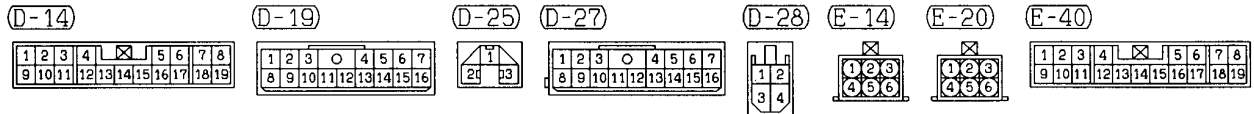
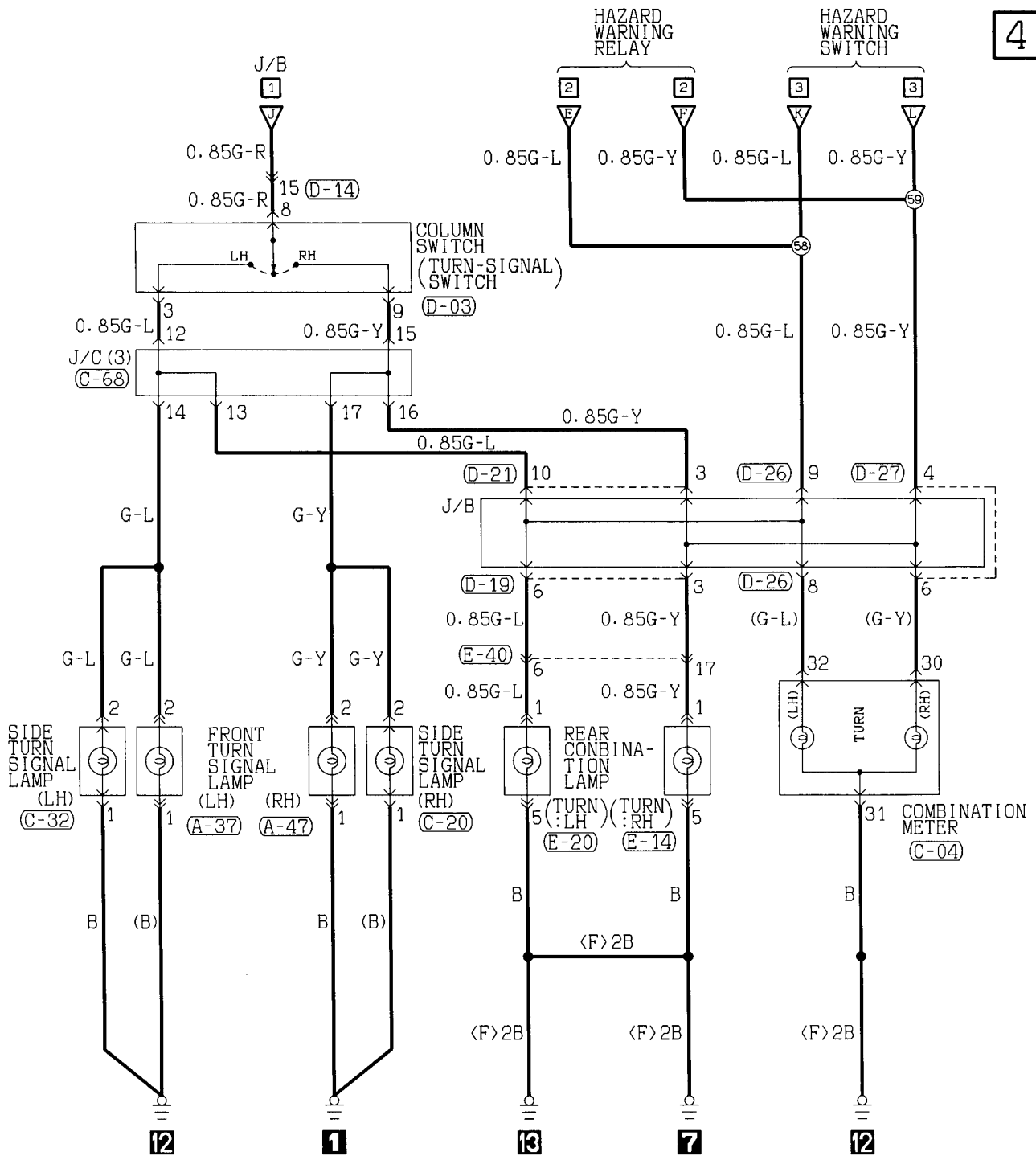

Wire colour code
 B : Black LG : Light green G : Green L : Blue W : White Y : Yellow SB : Sky blue
 BR : Brown O : Orange GR : Gray R : Red P : Pink V : Violet

CENTRAL DOOR LOCKING SYSTEM <L.H. drive vehicles with keyless entry system> (CONTINUED)

5

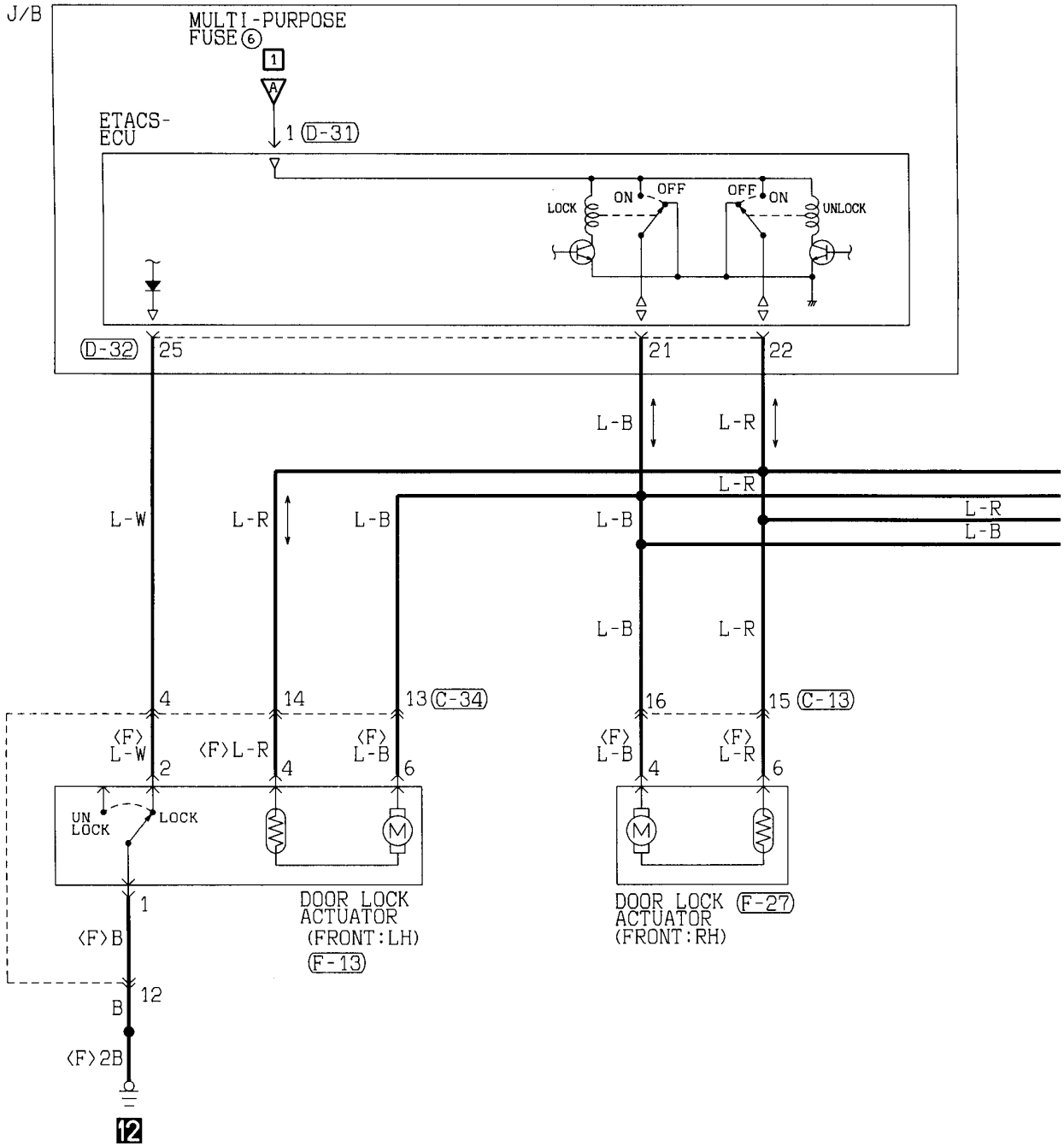

C-01

1	2	3	4	5	6	7	8	9		
10	11	12	13	14	15	16	17	18	19	20

C-13

1	2	3	4	5	6	7	8			
9	10	11	12	13	14	15	16	17	18	19

C-34

1	2	3	4	5	6	7	8			
9	10	11	12	13	14	15	16	17	18	19

D-31

1	2	3	4	5	6	7	8	9	10	11	12
---	---	---	---	---	---	---	---	---	----	----	----

D-32

21	22	23	24	25	26	27	28
29	30	31	32	33	34	35	36

6

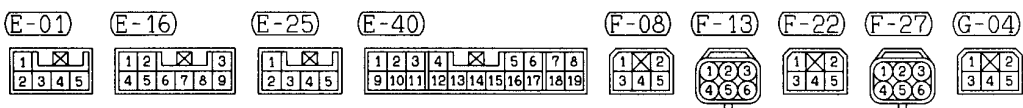
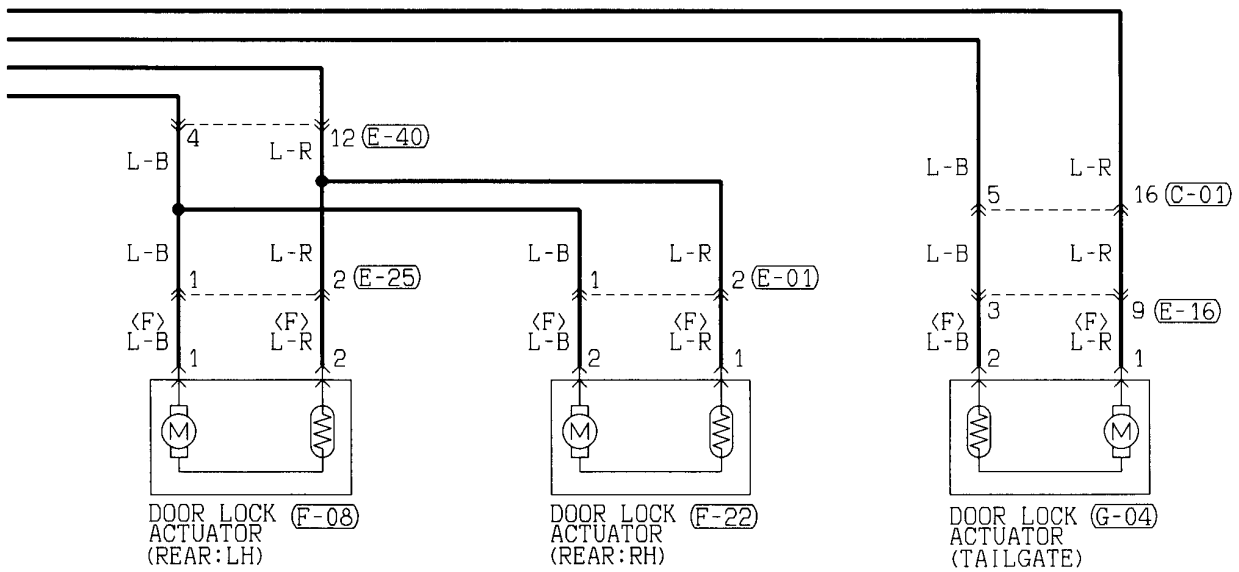

Wire colour code
 B:Black LG:Light green G:Green L:Blue W:White Y:Yellow SB:Sky blue
 BR:Brown O:Orange GR:Gray R:Red P:Pink V:Violet

CENTRAL DOOR LOCKING SYSTEM <L.H. drive vehicles with keyless entry system> (CONTINUED)

7

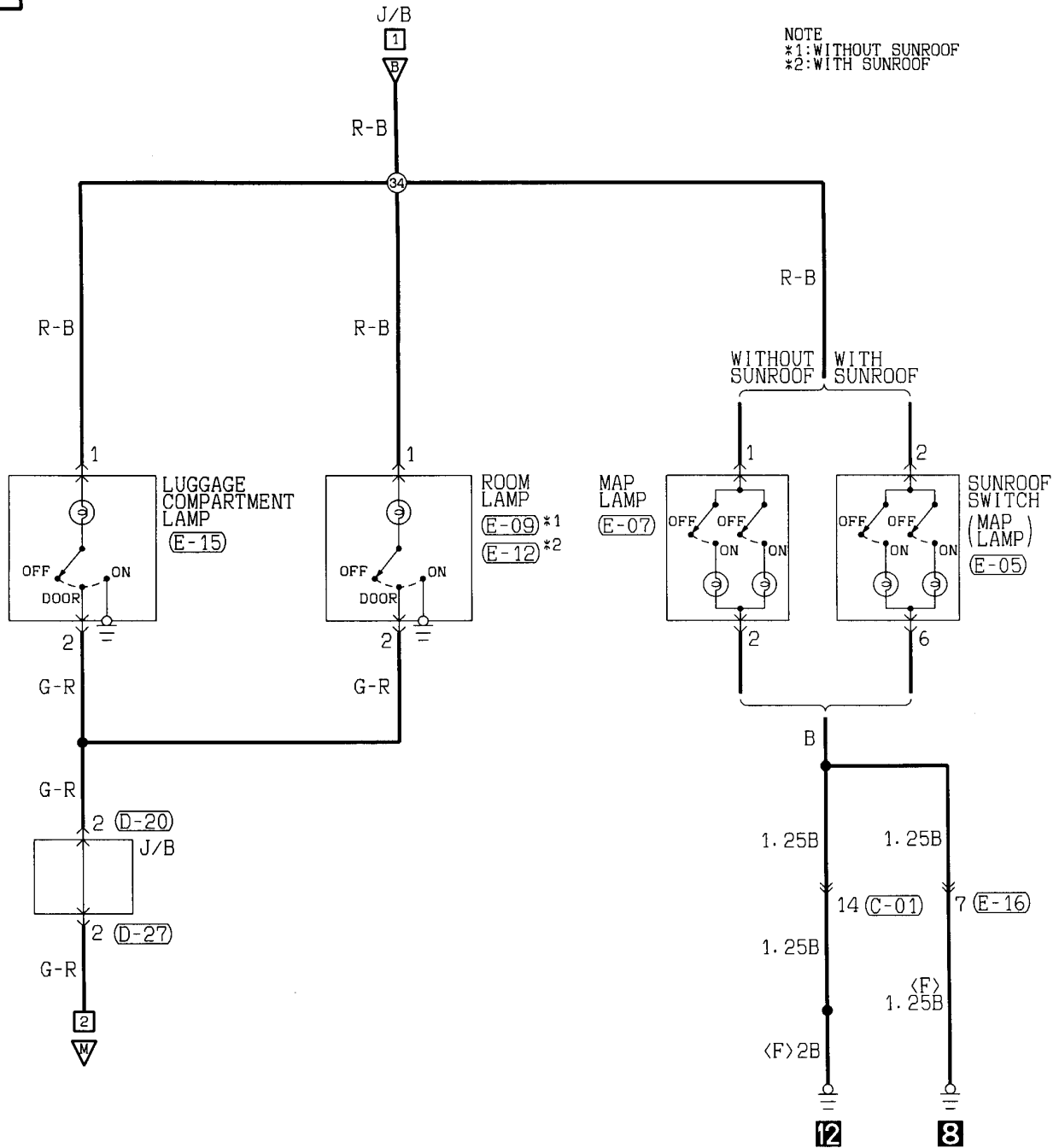

NOTE
 *1: WITHOUT SUNROOF
 *2: WITH SUNROOF

(C-01)

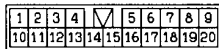

(C-03)



(D-20)



(D-27)

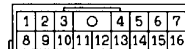

(E-05)



(E-07)



(E-08)



(E-09)



(E-12)



8

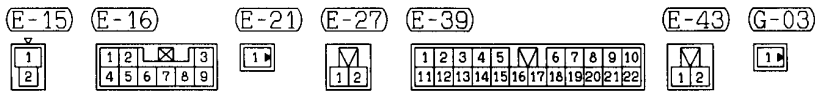
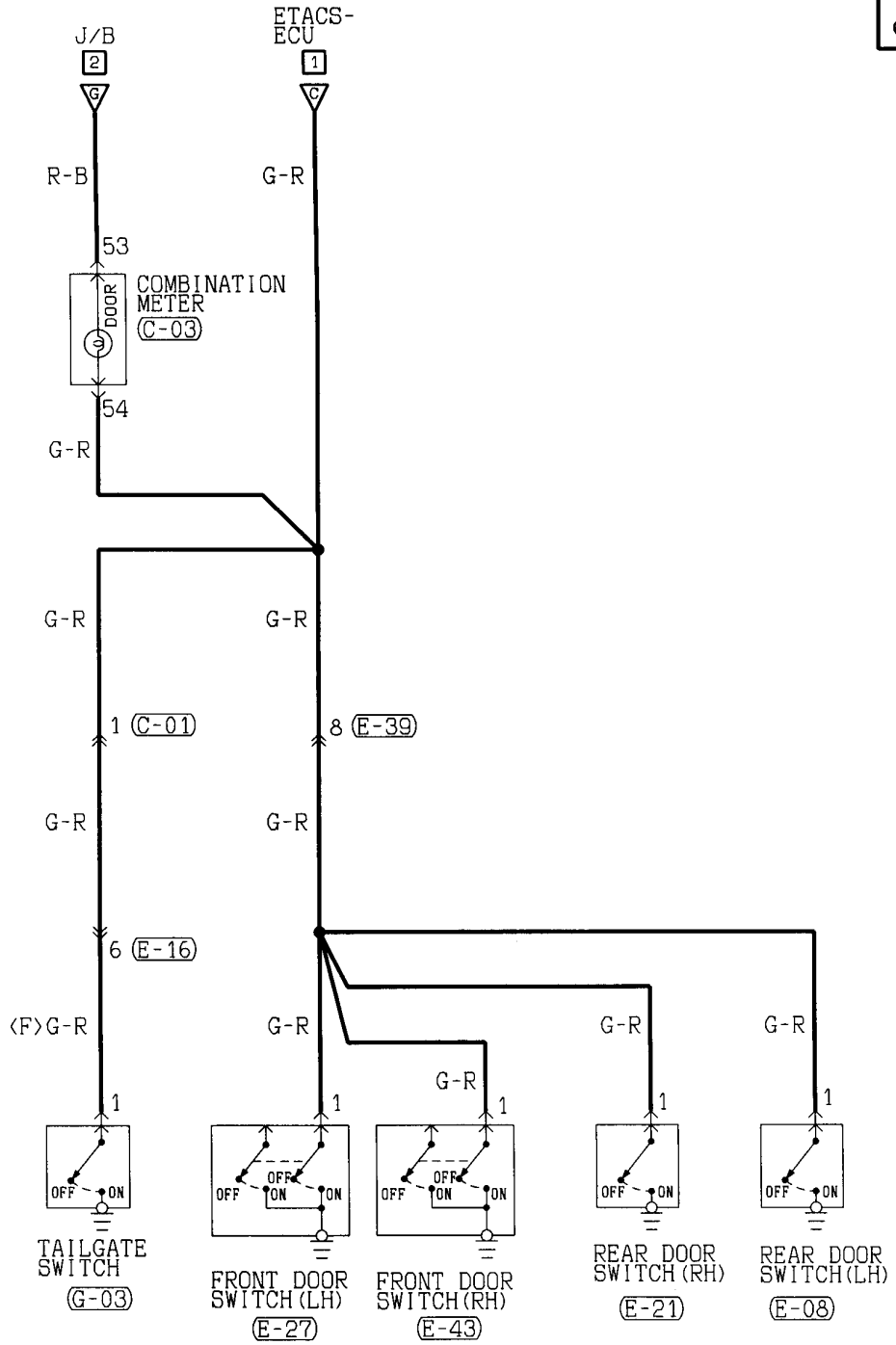

Wire colour code
 B : Black LG : Light green G : Green L : Blue W : White Y : Yellow SB : Sky blue
 BR : Brown O : Orange GR : Gray R : Red P : Pink V : Violet

CENTRAL DOOR LOCKING SYSTEM <L.H. drive vehicles with keyless entry system> (CONTINUED)

9

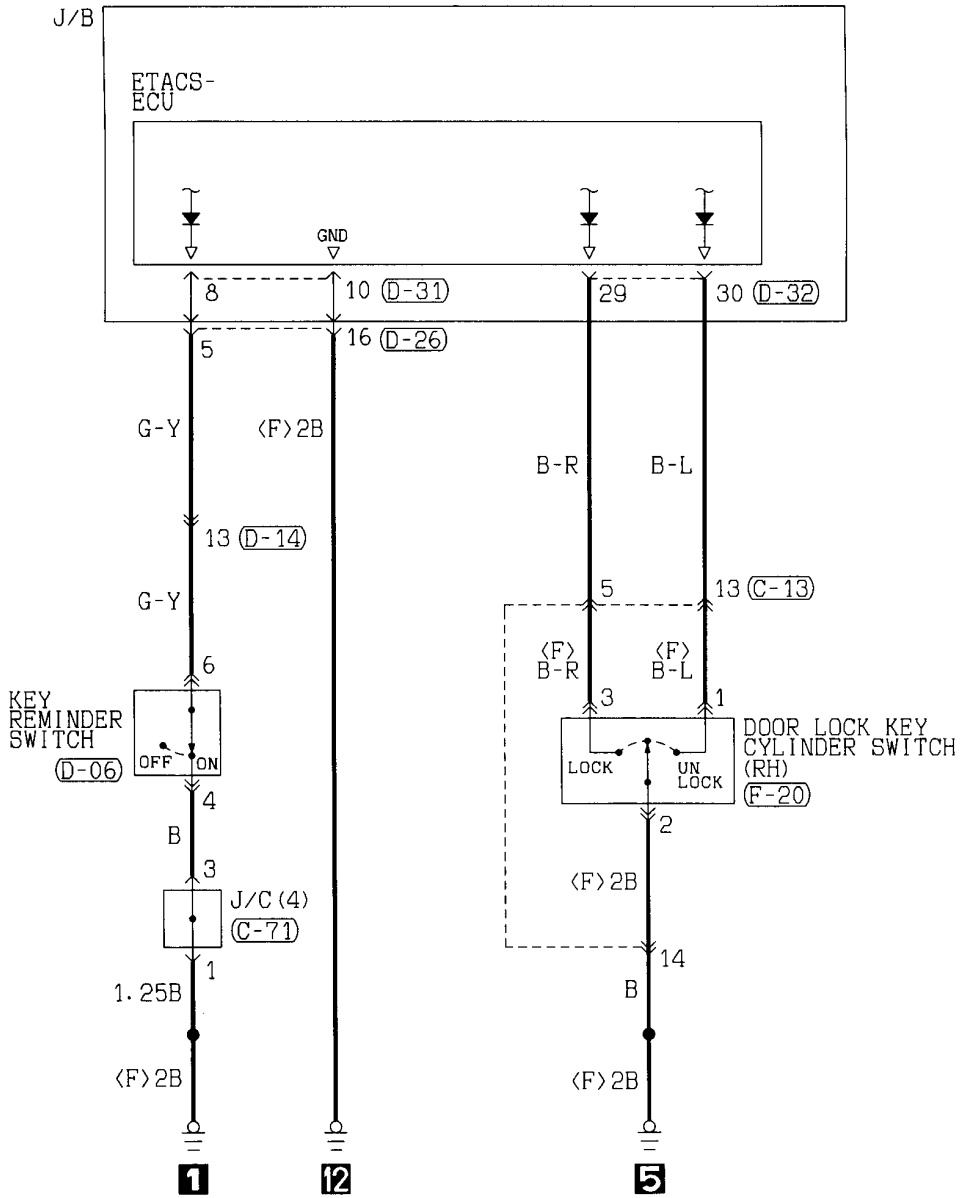

(C-13)

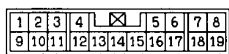

(C-71)



(D-06)

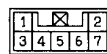

(D-26)

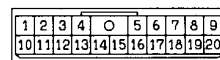

(D-31)

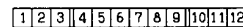

(D-32)



(F-20)



Wire colour code
 B : Black LG: Light green G : Green L : Blue W : White Y : Yellow SB: Sky blue
 BR: Brown O : Orange GR: Gray R : Red P : Pink V : Violet

NOTES

CENTRAL DOOR LOCKING SYSTEM

L.H. drive vehicles without keyless entry system

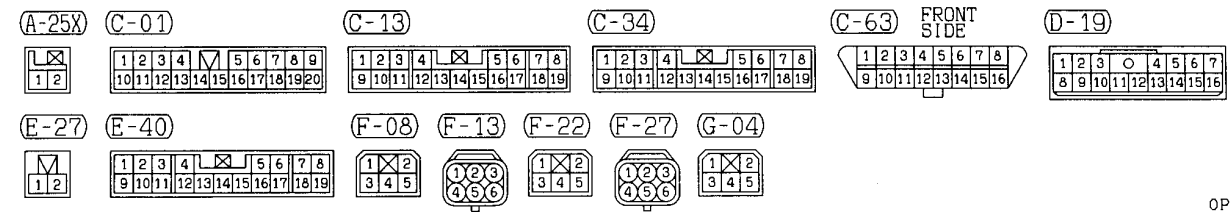
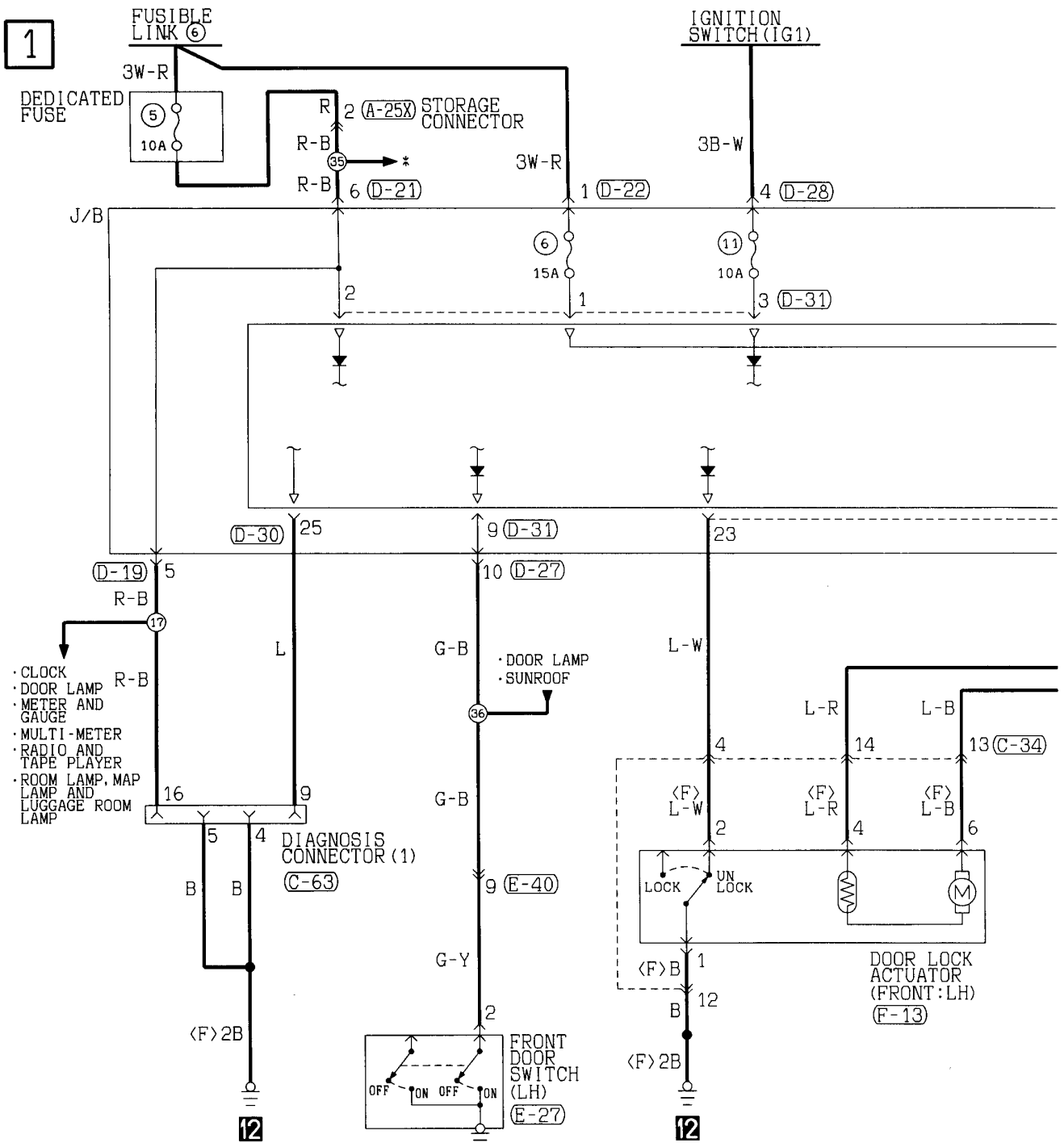

2

NOTE
*:IGNITION KEY
CYLINDER
ILLUMINATION
LAMP

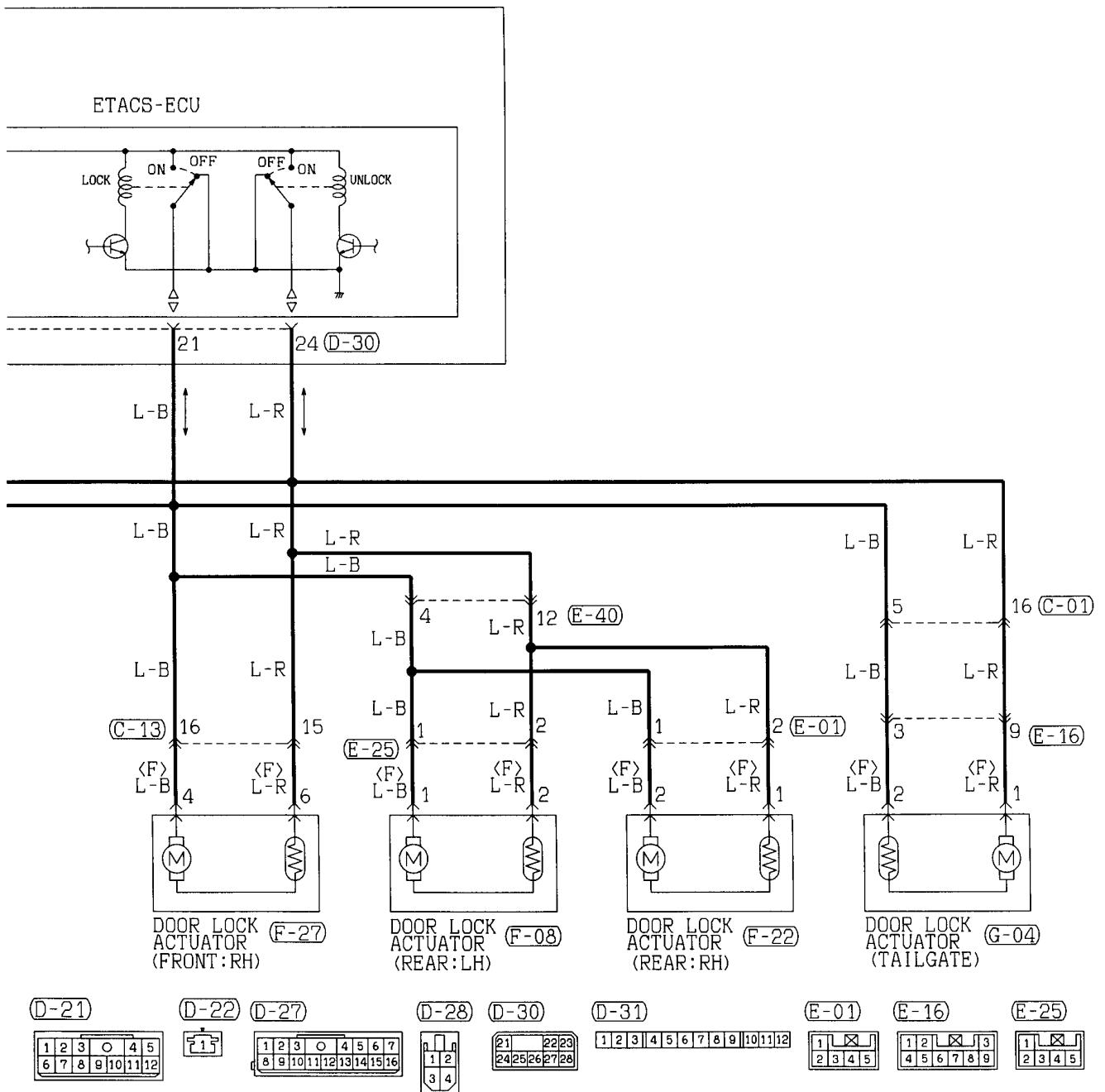

Wire colour code
 B :Black LG:Light green G :Green L :Blue W :White Y :Yellow SB:Sky blue
 BR:Brown O :Orange GR:Gray R :Red P :Pink V :Violet

CENTRAL DOOR LOCKING SYSTEM <L.H. drive vehicles without keyless entry system> (CONTINUED)

3

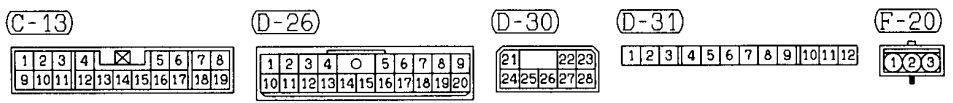
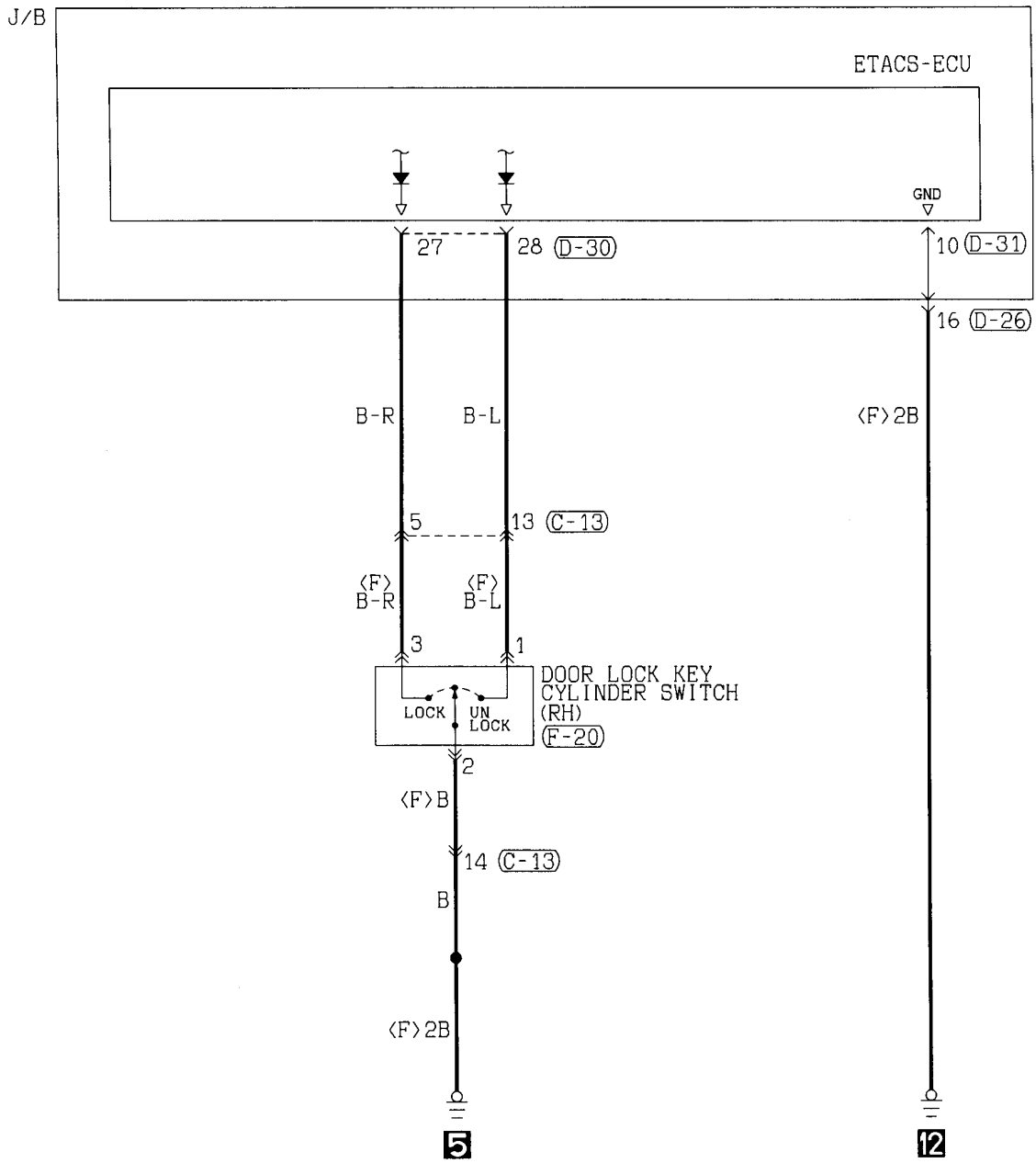

Wire colour code
 B : Black LG: Light green G : Green L : Blue W : White Y : Yellow SB: Sky blue
 BR: Brown O : Orange GR: Gray R : Red P : Pink V : Violet

NOTES

CENTRAL DOOR LOCKING SYSTEM

R.H. drive vehicles with keyless entry system

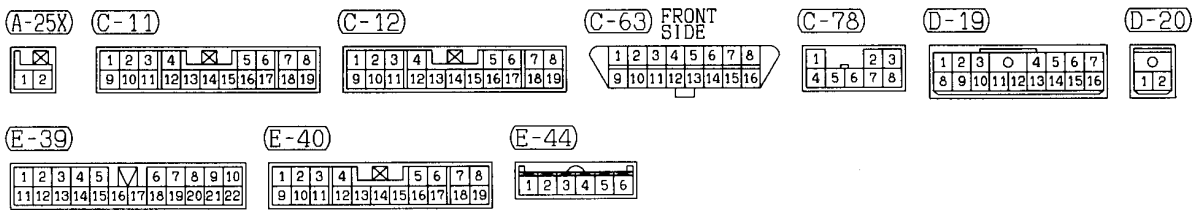
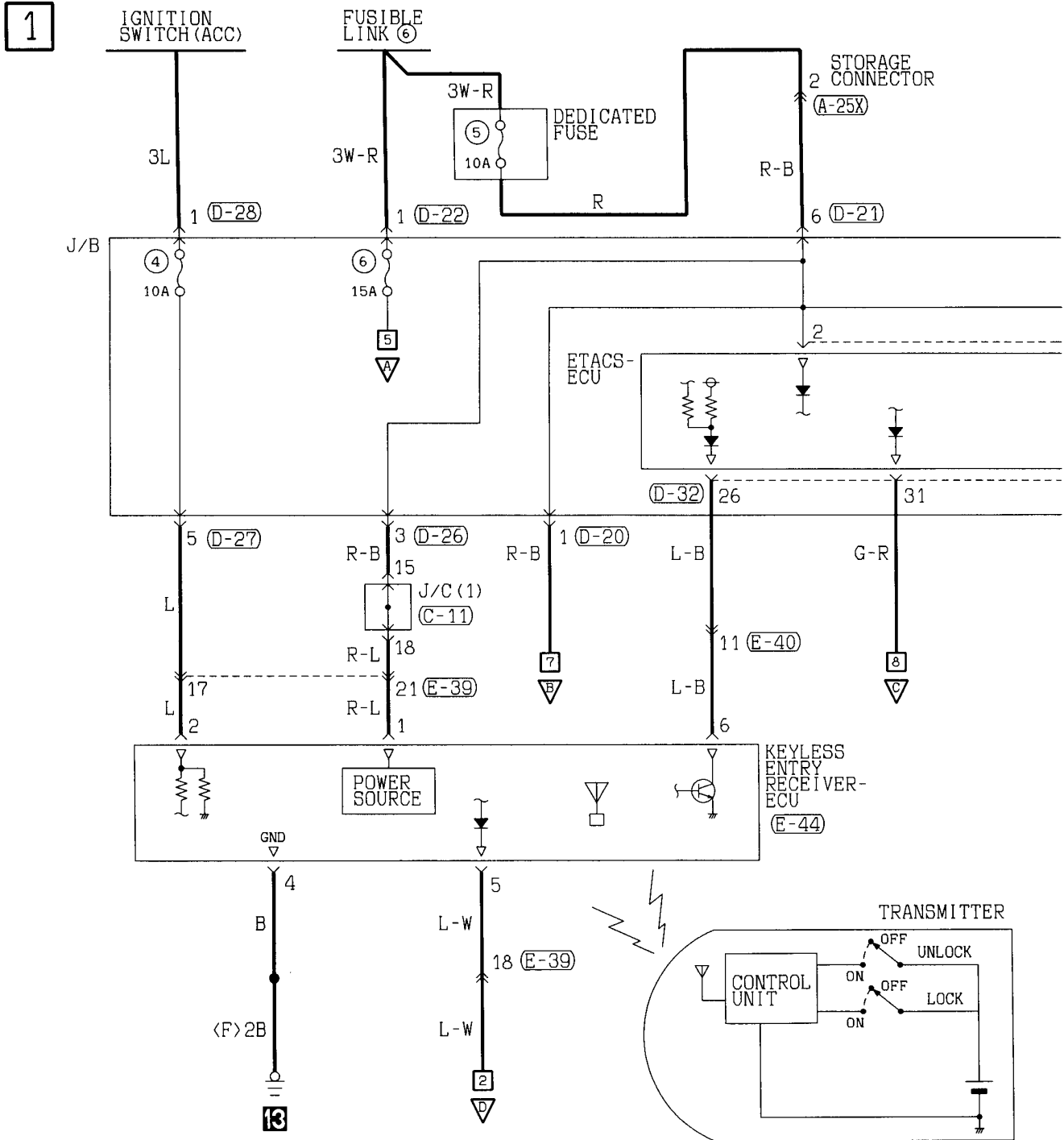

2

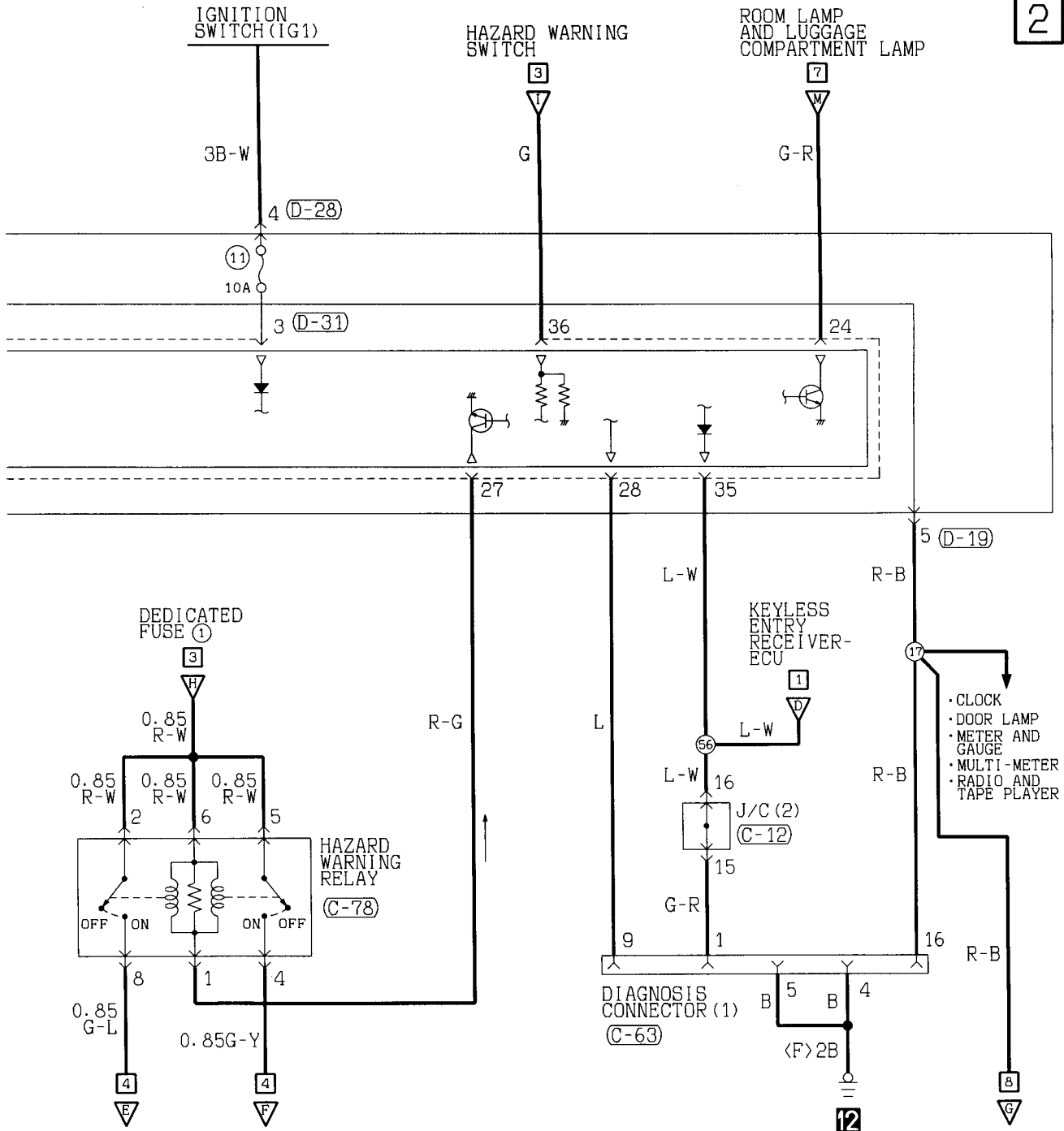

D-21

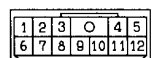

D-22



D-26

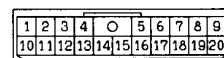

D-27

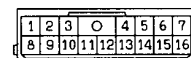

D-28



D-31

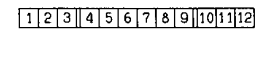

D-32



Wire colour code
 B :Black LG:Light green G :Green L :Blue W :White Y :Yellow SB:Sky blue
 BR:Brown O :Orange GR:Gray R :Red P :Pink V :Violet

CENTRAL DOOR LOCKING SYSTEM <R.H. drive vehicles with keyless entry system> (CONTINUED)

3

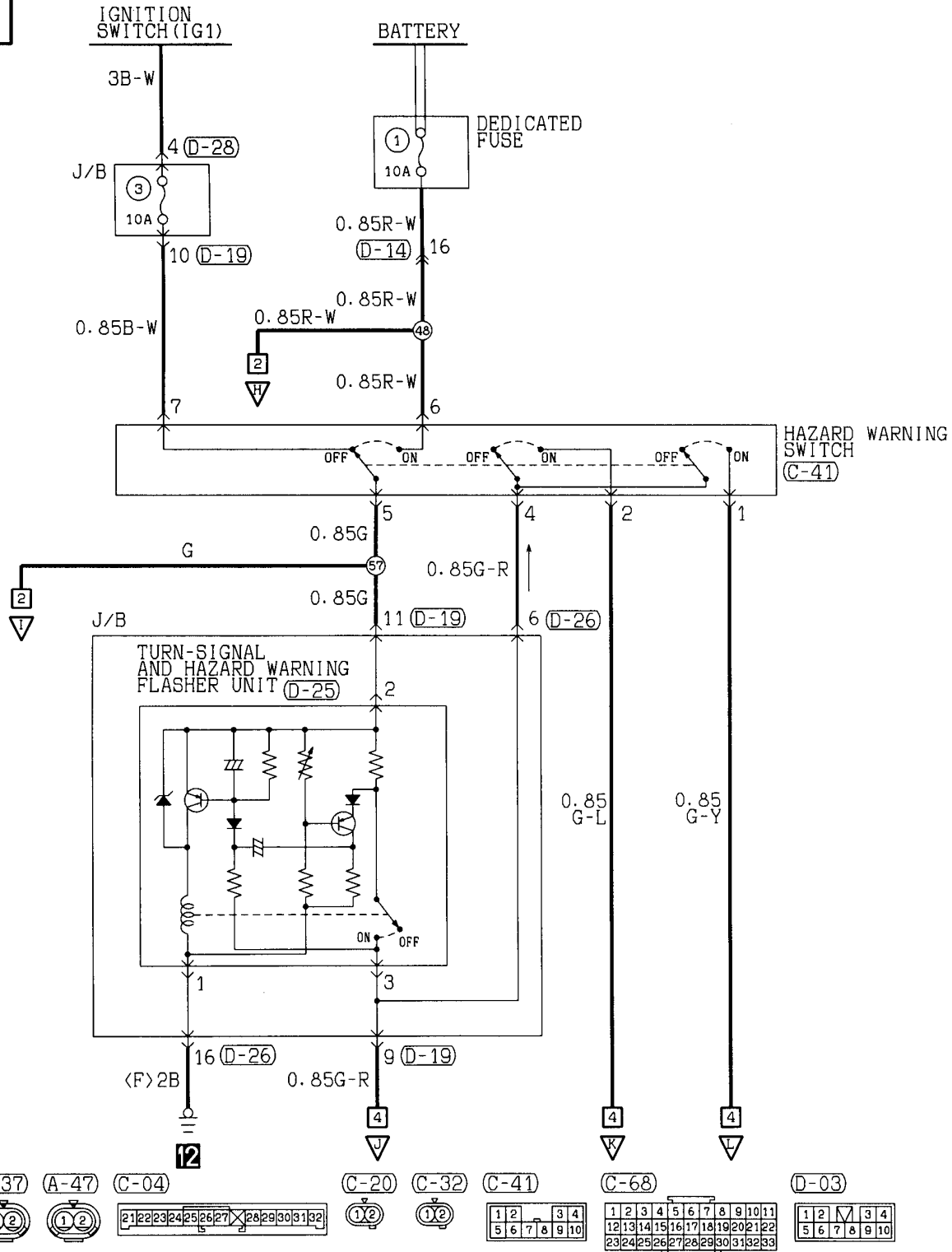

4

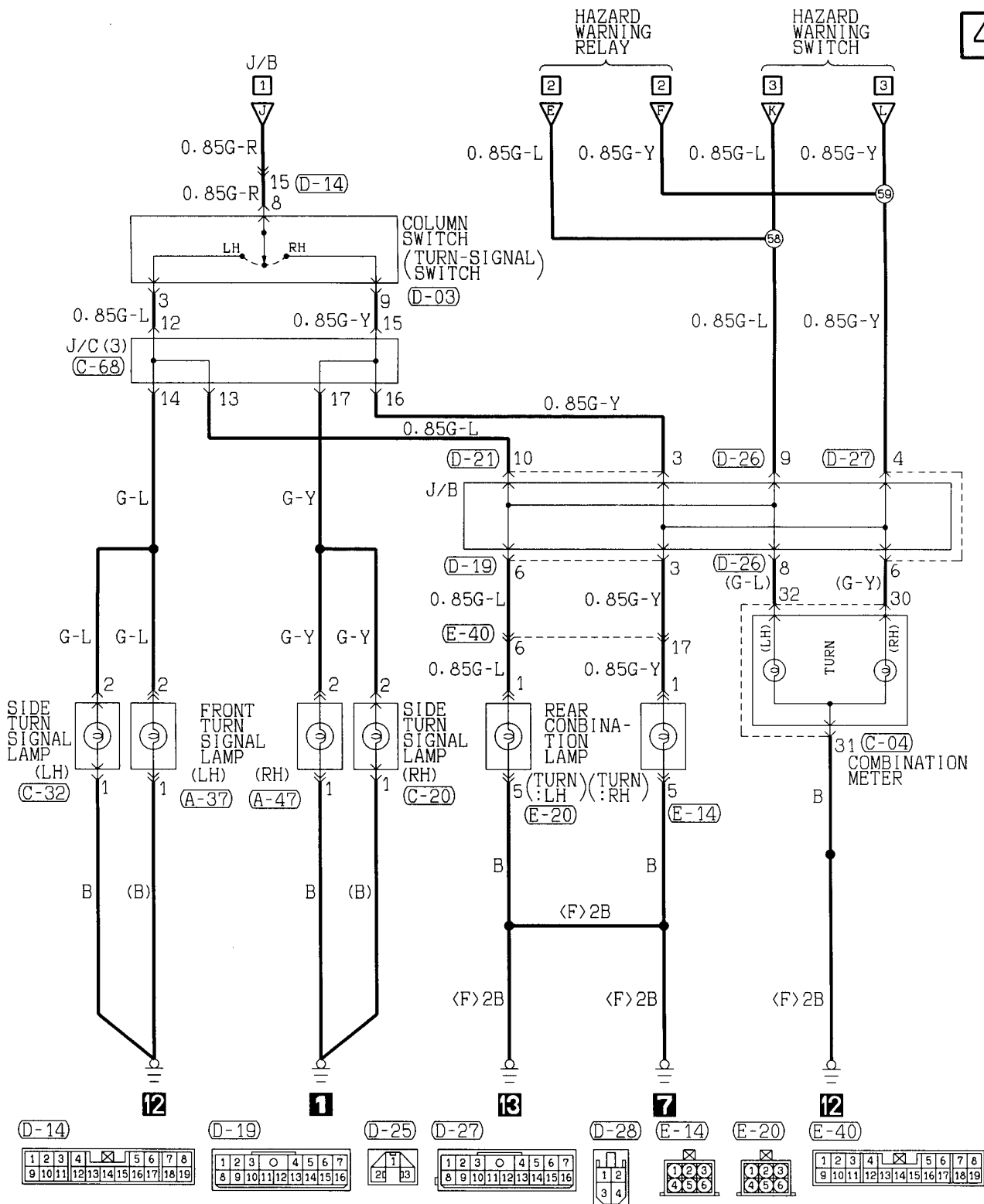

Wire colour code
 B :Black LG:Light green G :Green L :Blue W :White Y :Yellow SB:Sky blue
 BR:Brown O :Orange GR:Gray R :Red P :Pink V :Violet

CENTRAL DOOR LOCKING SYSTEM <R.H. drive vehicles with keyless entry system> (CONTINUED)

5

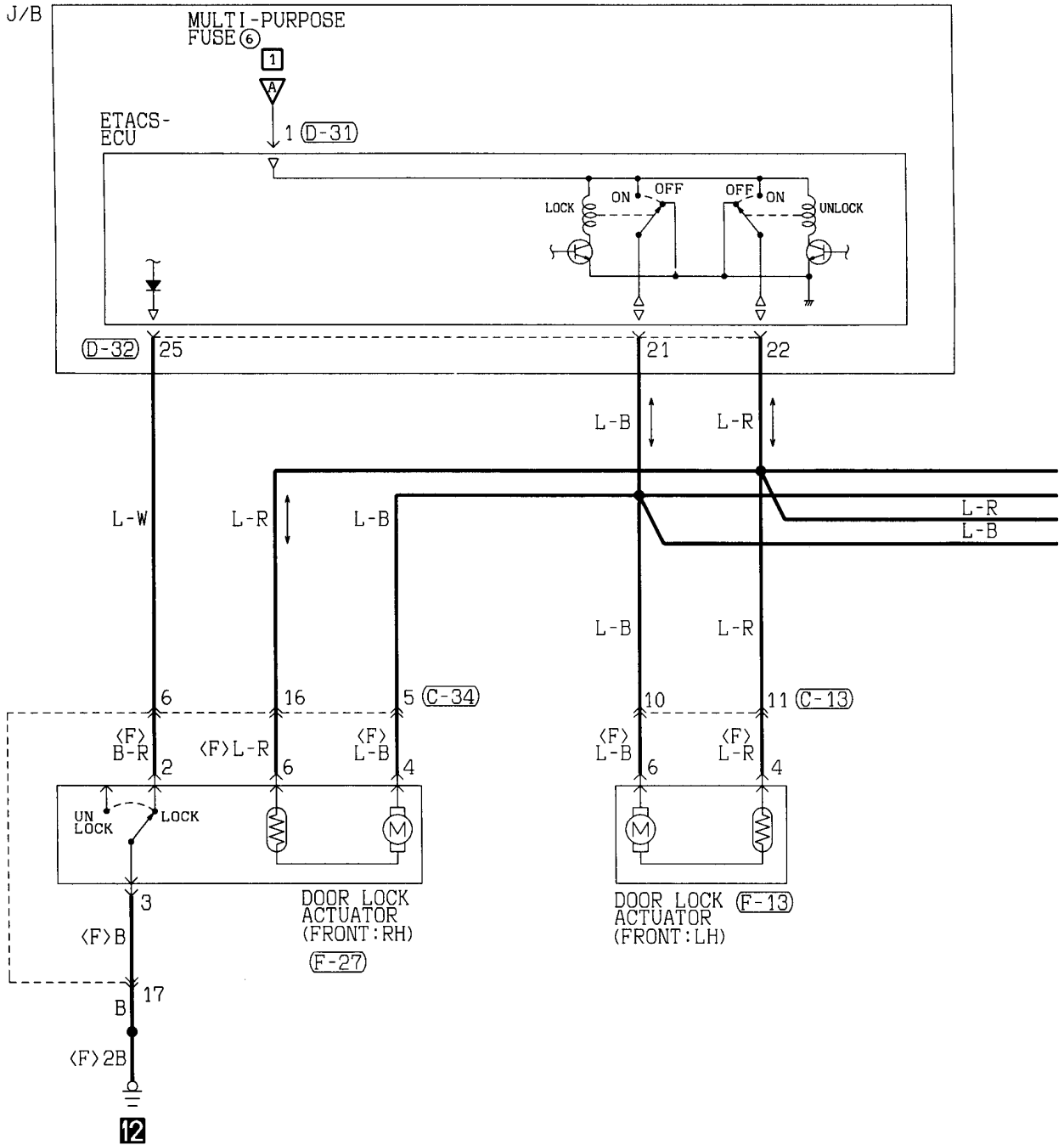

(C-01)

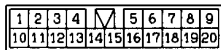

(C-13)

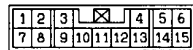

(C-34)

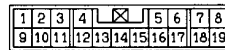

(D-31)

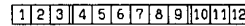

(D-32)

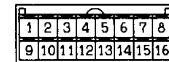

6

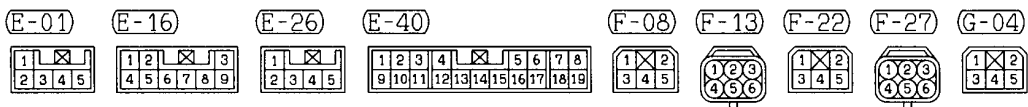
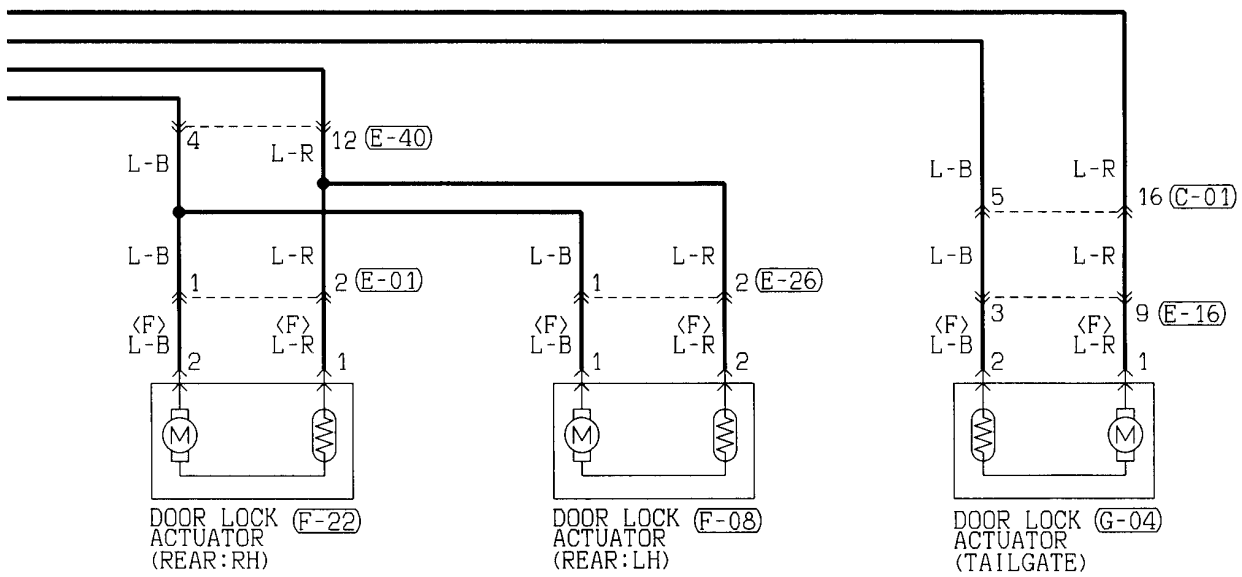

Wire colour code
 B :Black LG:Light green G :Green L :Blue W :White Y :Yellow SB:Sky blue
 BR:Brown O :Orange GR:Gray R :Red P :Pink V :Violet

CENTRAL DOOR LOCKING SYSTEM <R.H. drive vehicles with keyless entry system> (CONTINUED)

7

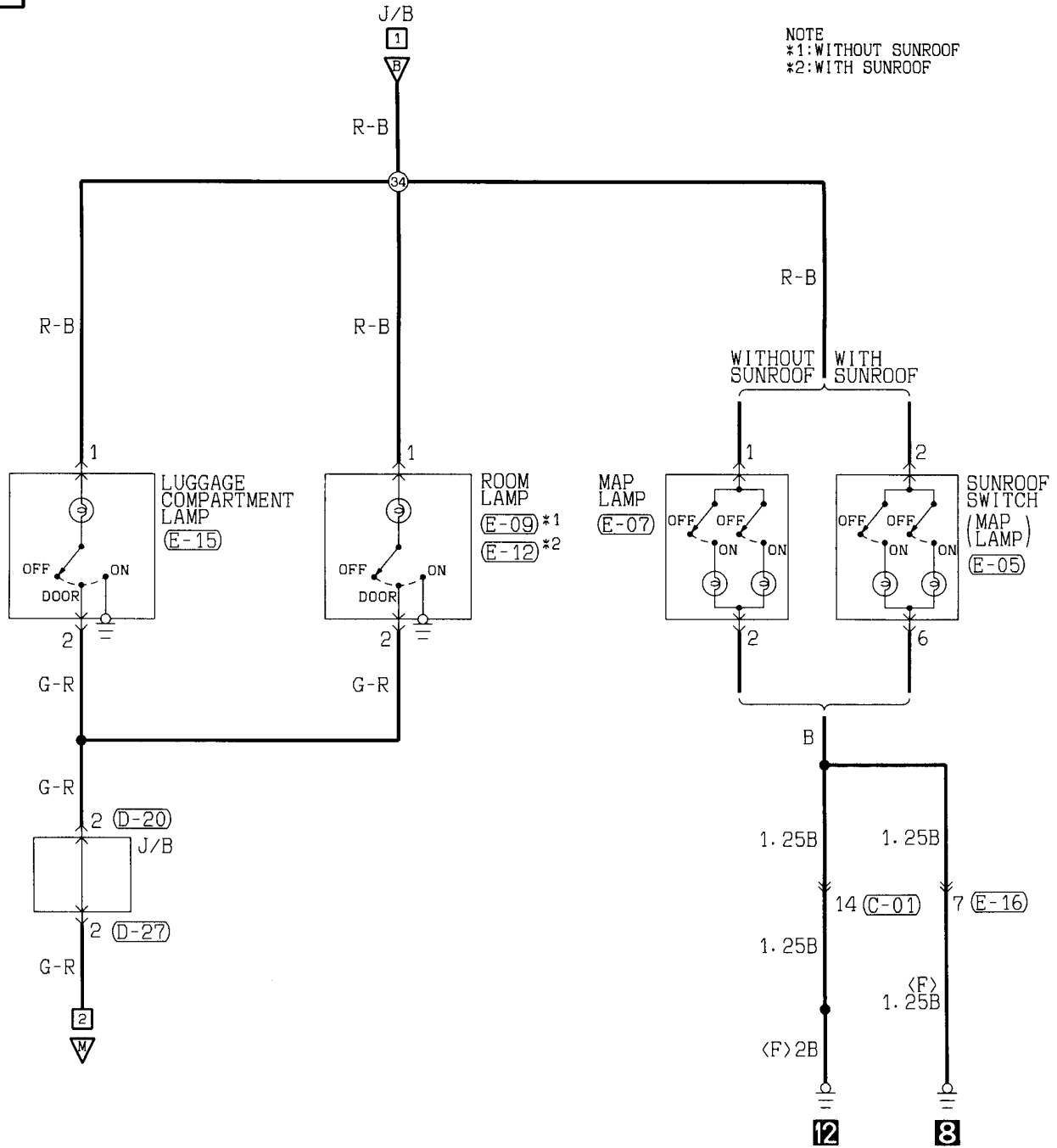

NOTE
 *1: WITHOUT SUNROOF
 *2: WITH SUNROOF

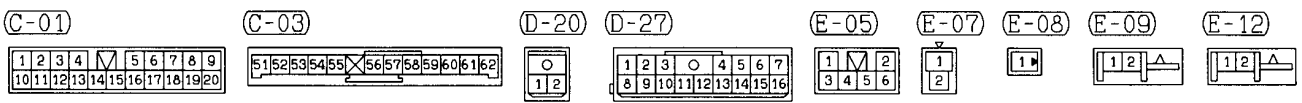

8

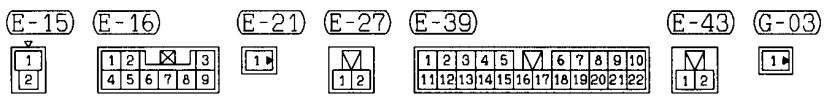
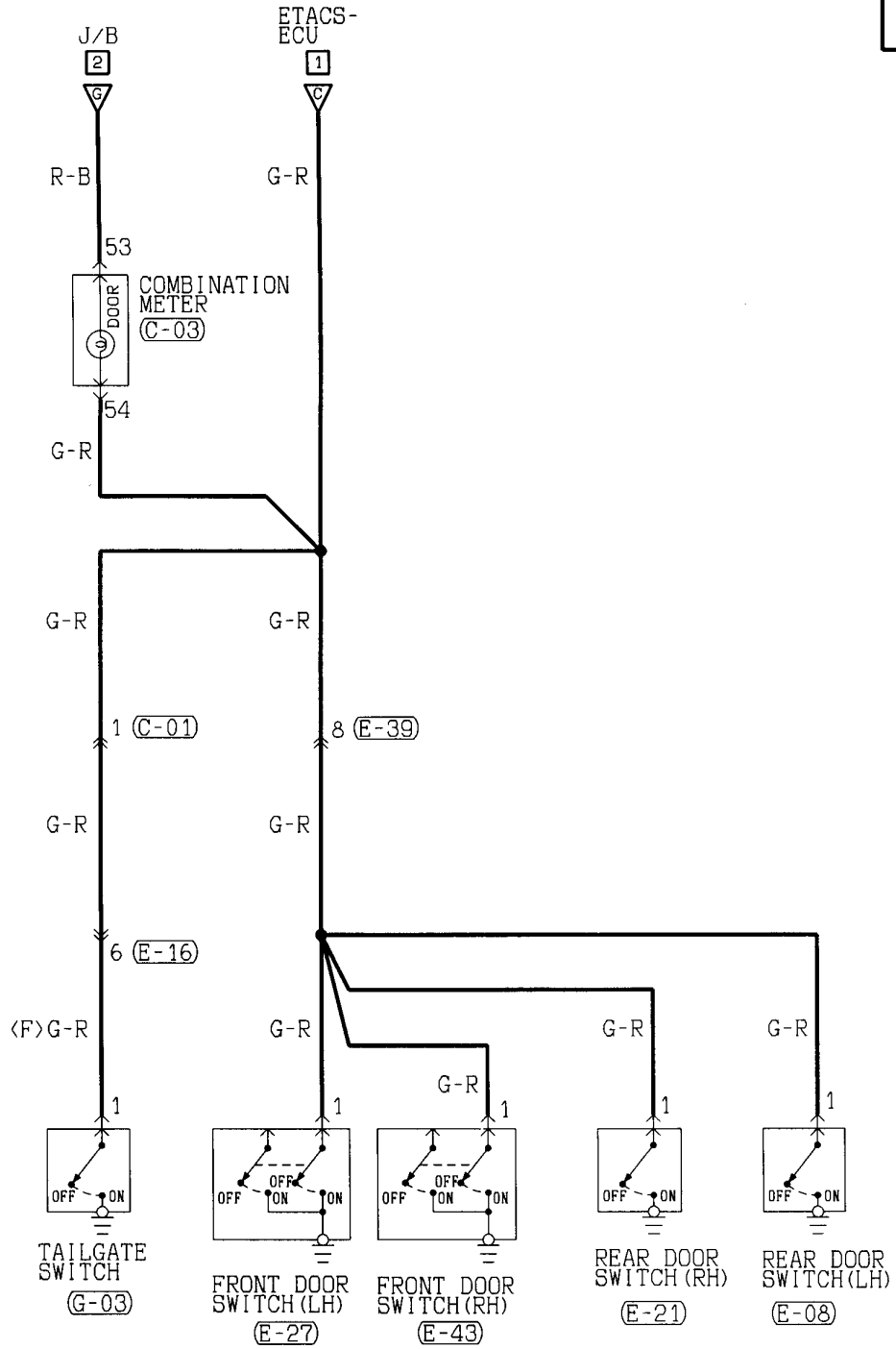

Wire colour code
 B :Black LG:Light green G :Green L :Blue W :White Y :Yellow SB:Sky blue
 BR:Brown O :Orange GR:Gray R :Red P :Pink V :Violet

CENTRAL DOOR LOCKING SYSTEM <R.H. drive vehicles with keyless entry system> (CONTINUED)

9

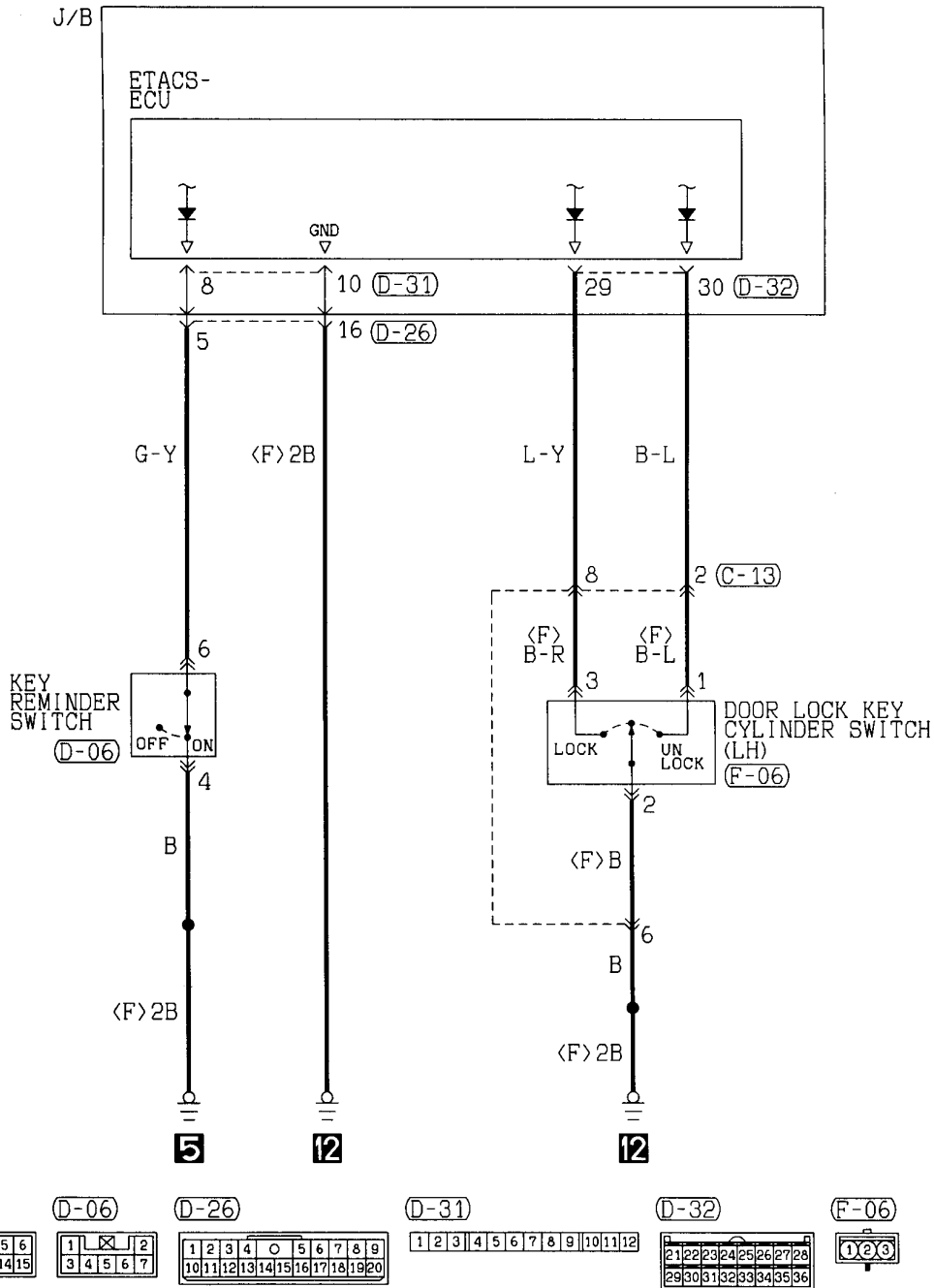

Wire colour code
 B :Black LG:Light green G :Green L :Blue W :White Y :Yellow SB:Sky blue
 BR:Brown O :Orange GR:Gray R :Red P :Pink V :Violet

NOTES

CENTRAL DOOR LOCKING SYSTEM

R.H. drive vehicles without keyless entry system

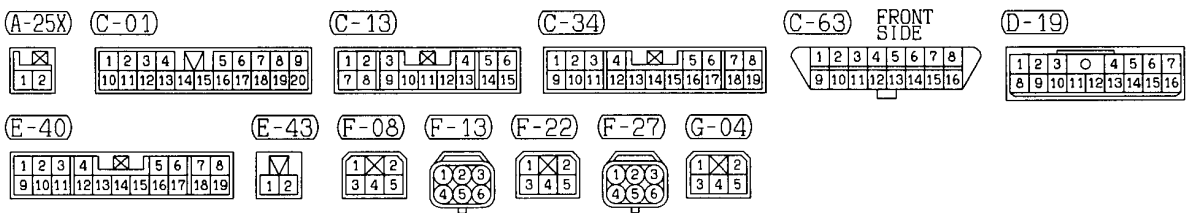
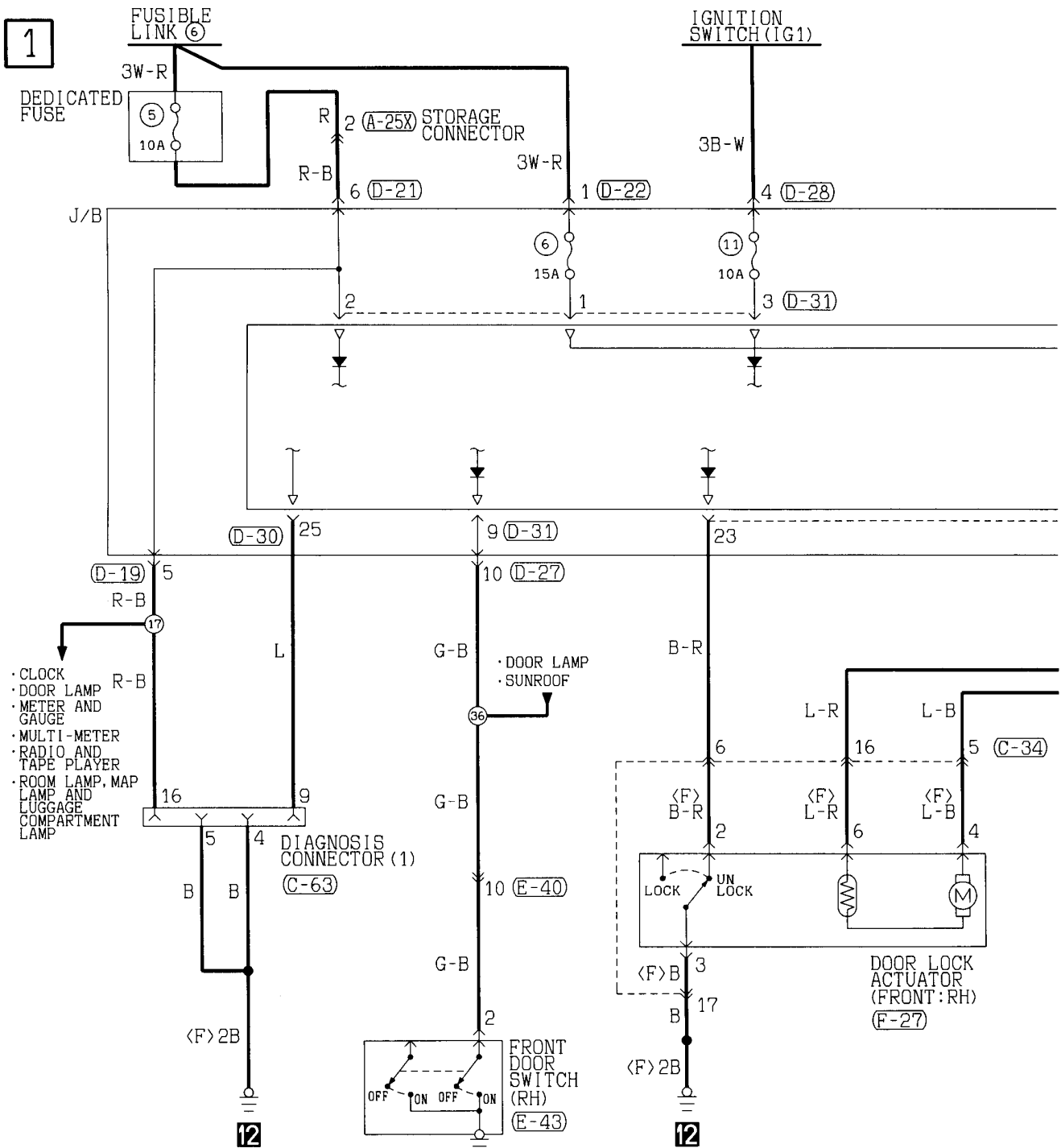

2

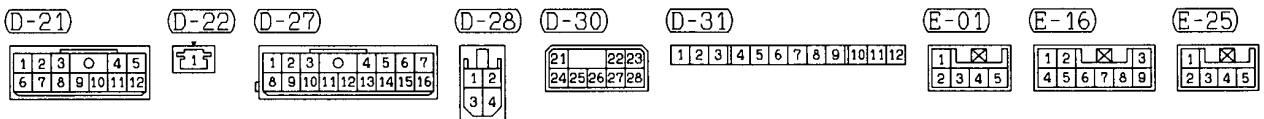
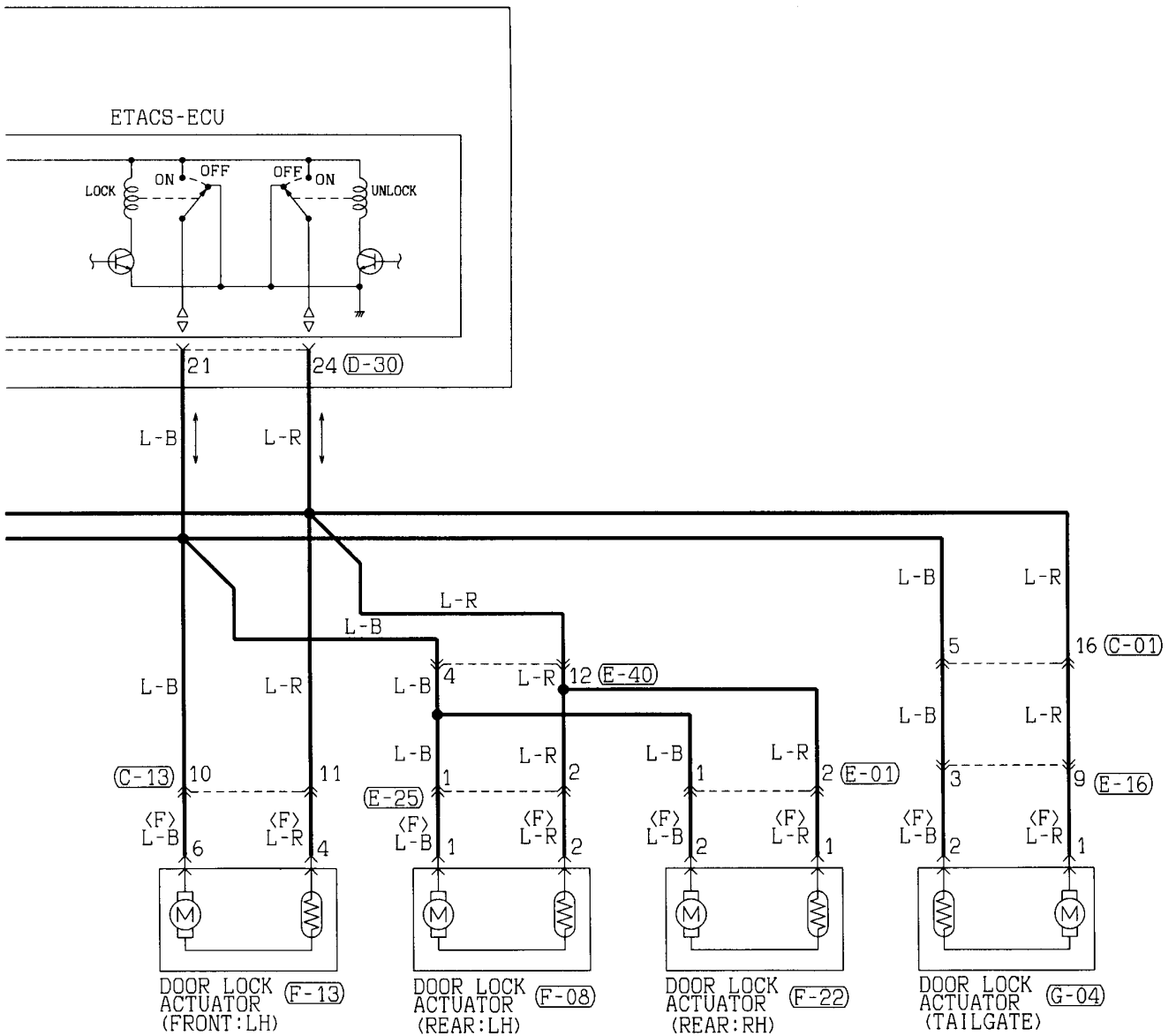

Wire colour code
 B : Black LG: Light green G : Green L : Blue W : White Y : Yellow SB: Sky blue
 BR: Brown O : Orange GR: Gray R : Red P : Pink V : Violet

CENTRAL DOOR LOCKING SYSTEM <R.H. drive vehicles without keyless entry system> (CONTINUED)

3

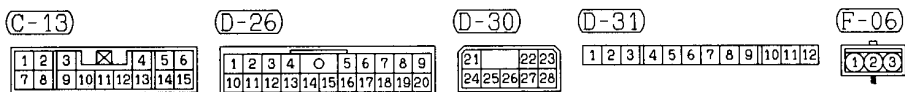
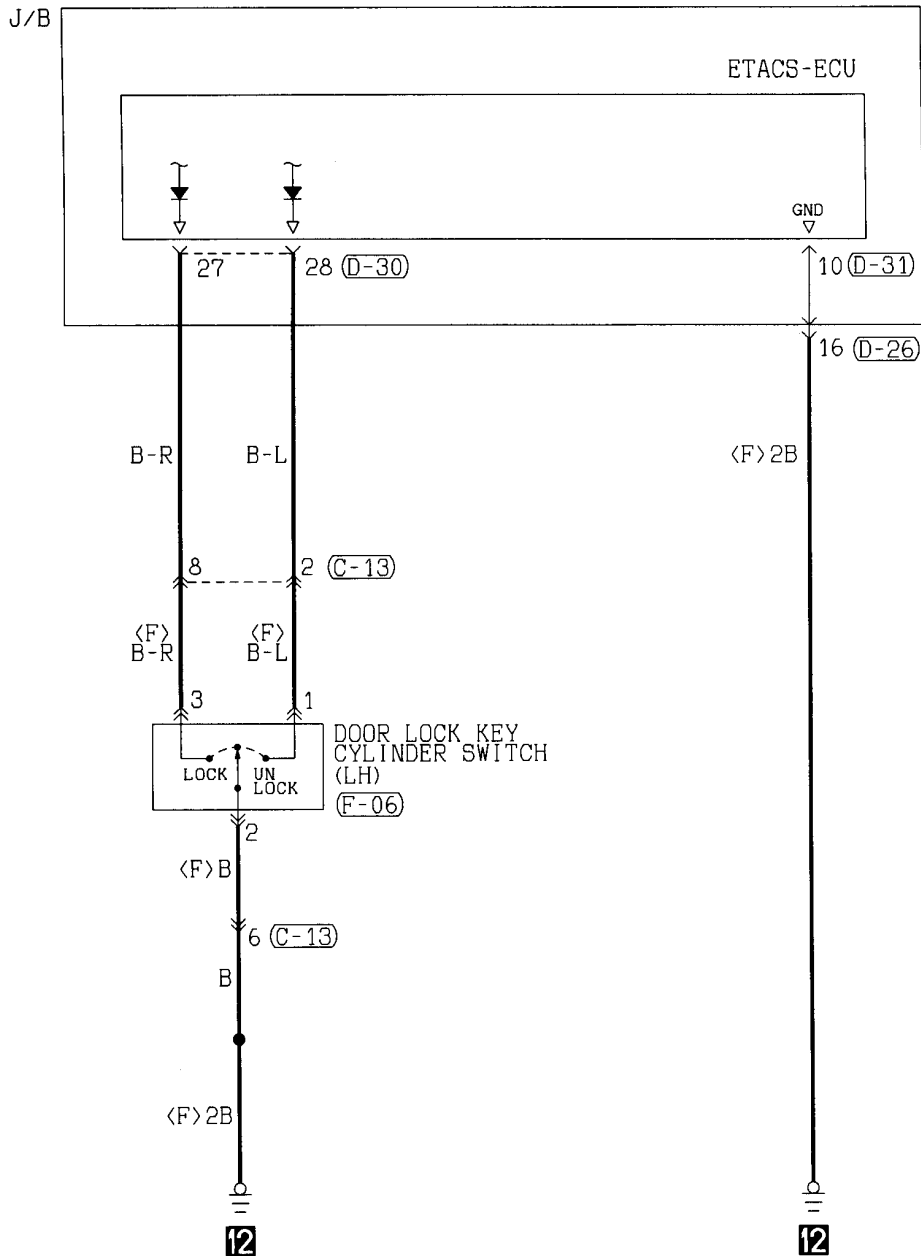

Wire colour code
 B : Black LG: Light green G : Green L : Blue W : White Y : Yellow SB: Sky blue
 BR: Brown O : Orange GR: Gray R : Red P : Pink V : Violet

NOTES

POWER WINDOWS

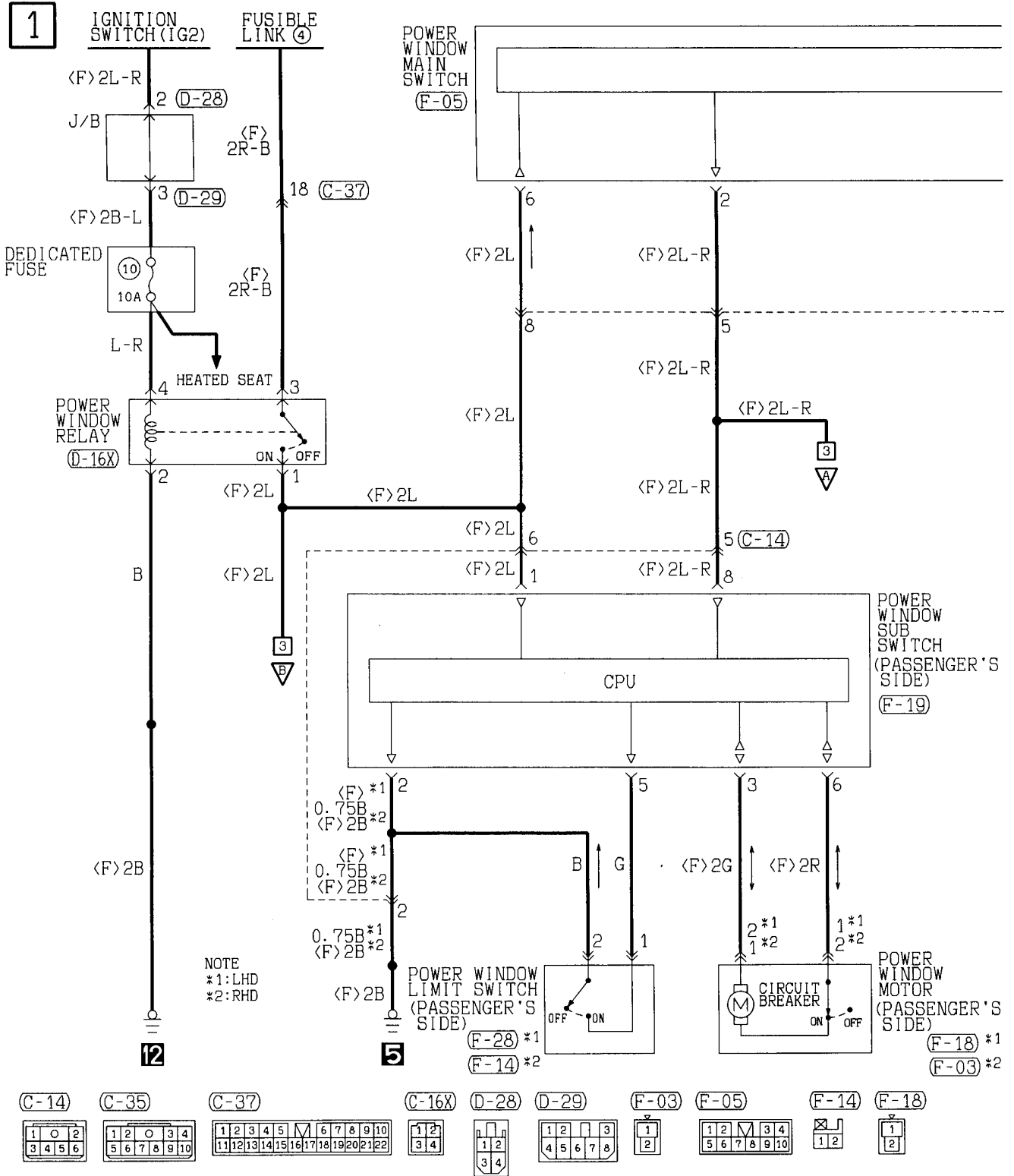

2

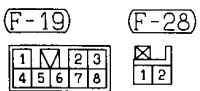
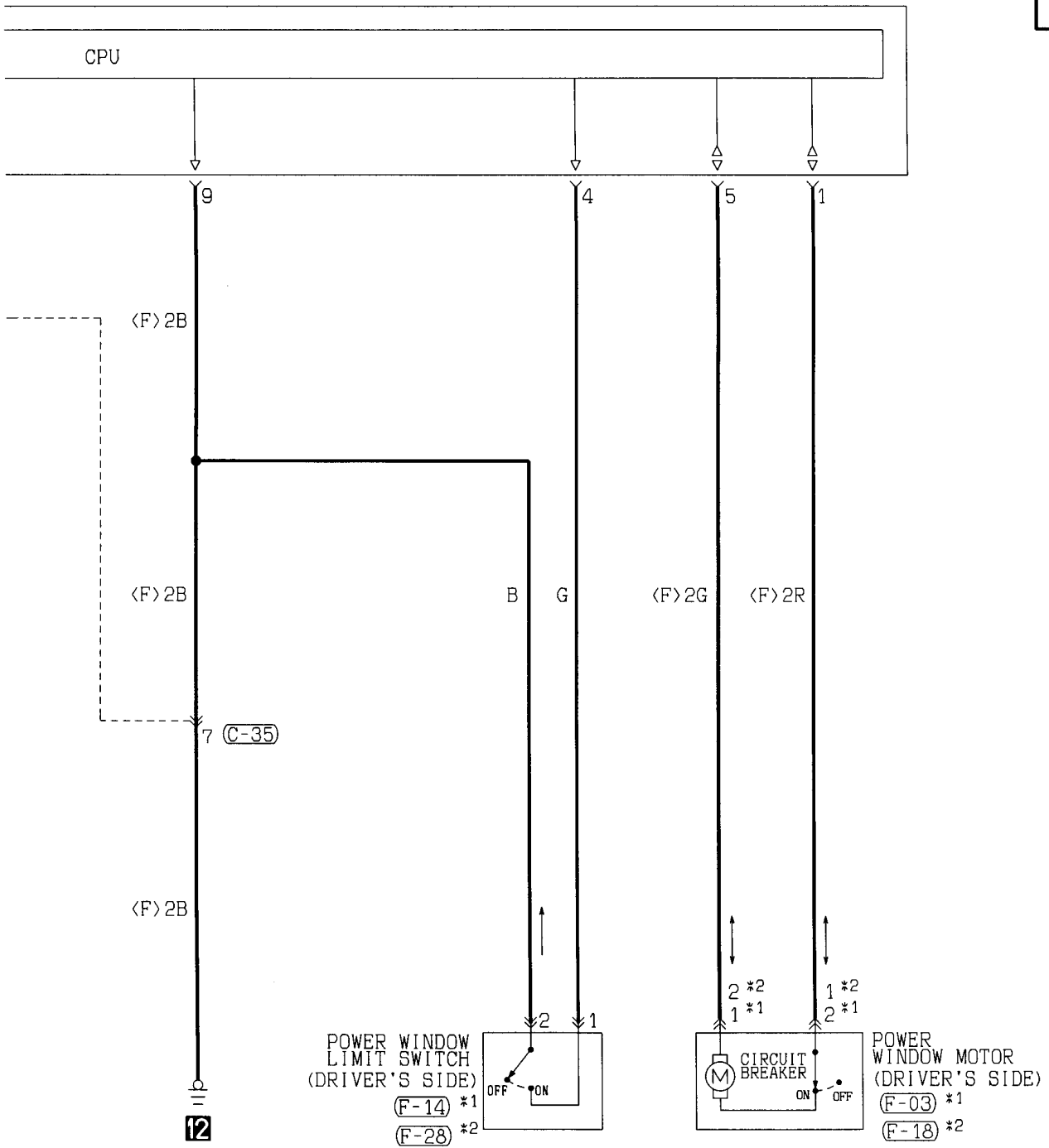

Wire colour code
 B :Black LG:Light green G :Green L :Blue W :White Y :Yellow SB:Sky blue
 BR:Brown O :Orange GR:Gray R :Red P :Pink V :Violet

POWER WINDOWS (CONTINUED)

3

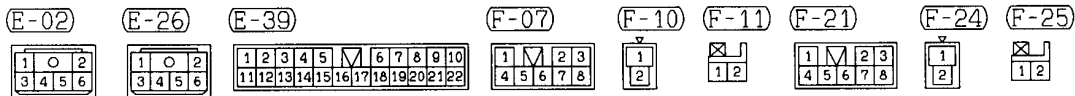
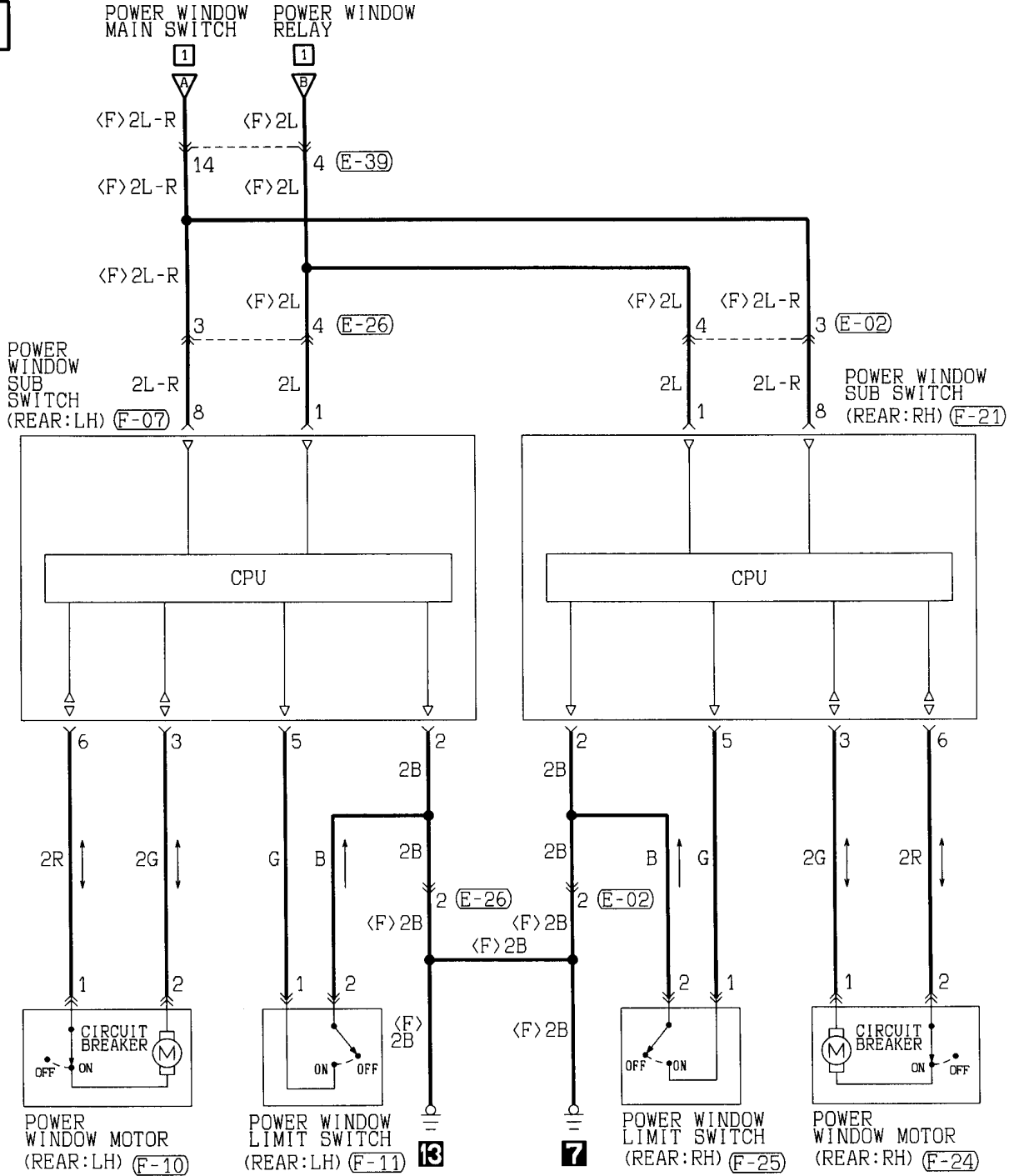

Wire colour code
 B : Black LG:Light green G :Green L :Blue W :White Y :Yellow SB:Sky blue
 BR:Brown O :Orange GR:Gray R :Red P :Pink V :Violet

NOTES

HEATER

Petrol-powered vehicles

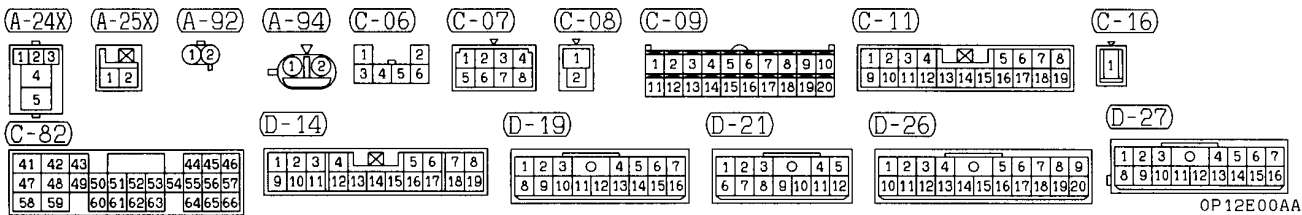
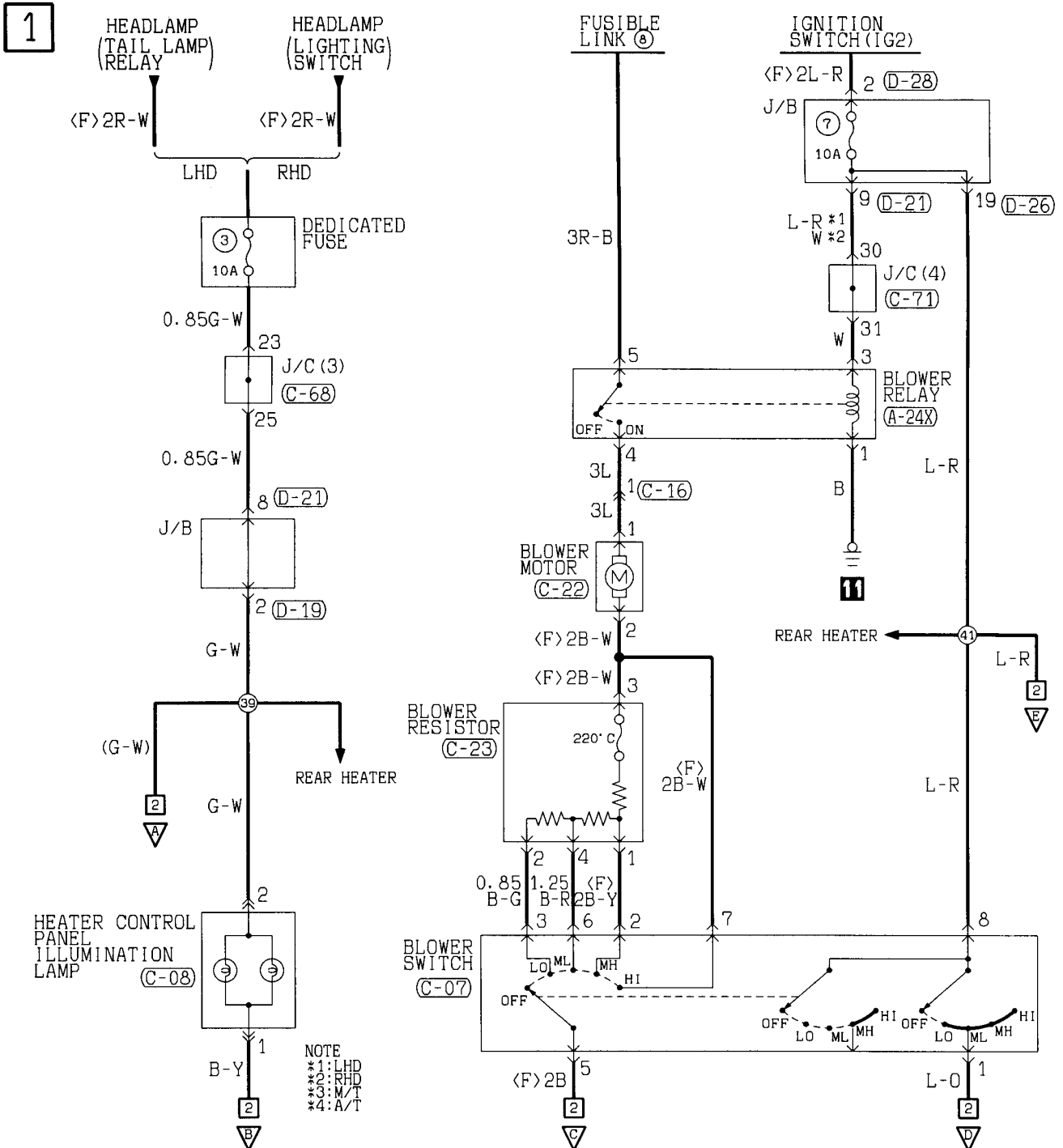

2

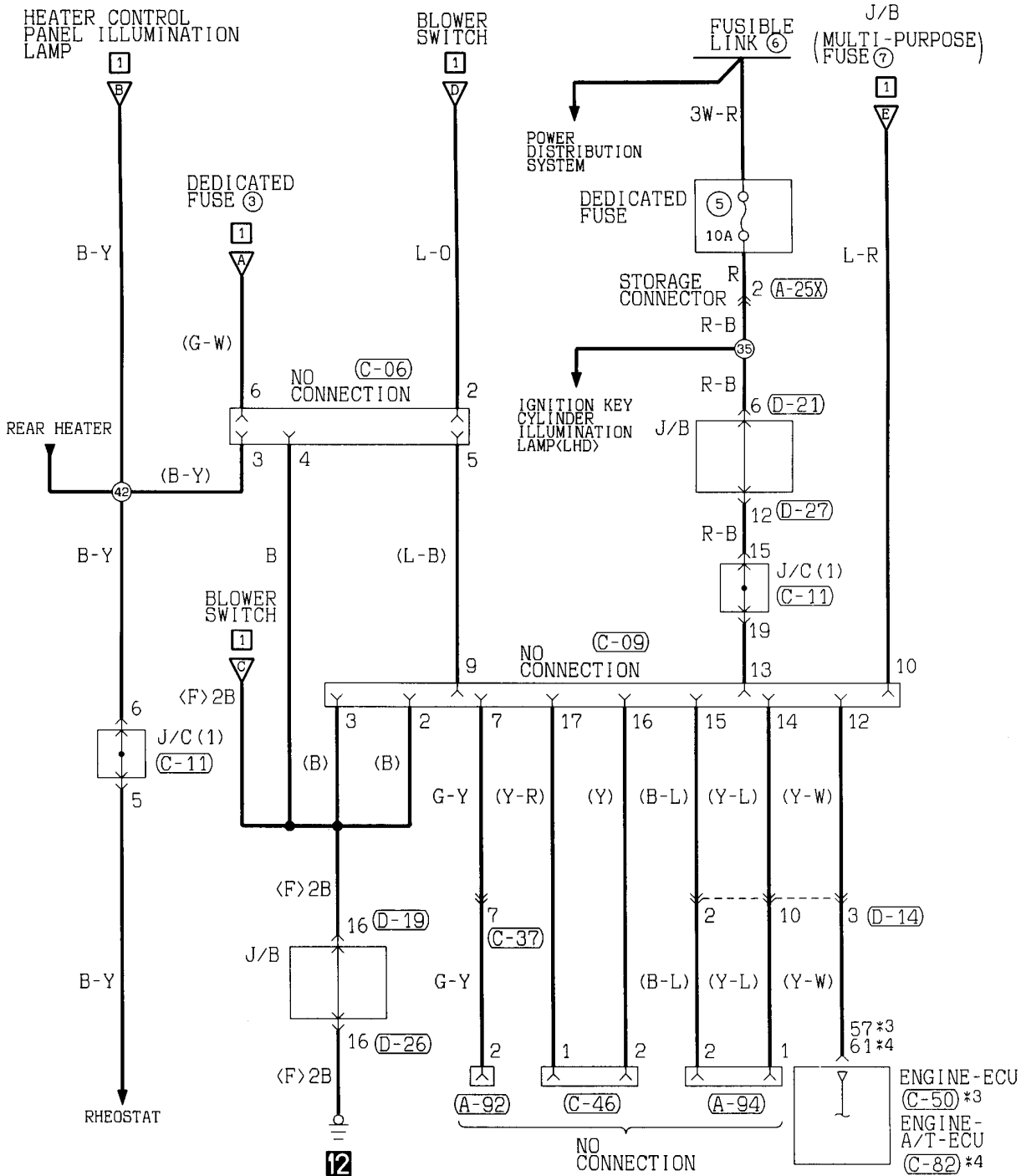

(C-22)	(C-23)	(C-37)	(C-46)	(C-50)	(C-68)	(C-71)
1 2 *1	1 2 3 4	1 2 3 4 5 6 7 8 9 10 11 12 13 14 15 16 17 18 19 20 21 22	1 2	5 1 5 2 5 3 5 4 5 5 5 6 5 7 5 8 5 9 6 0 6 1 6 2	1 2 3 4 5 6 7 8 9 10 11 12 13 14 15 16 17 18 19 20 21 22 23 24 25 26 27 28 29 30 31 32 33	1 2 3 4 5 6 7 8 9 10 11 12 13 14 15 16 17 18 19 20 21 22 23 24 25 26 27 28 29 30 31 32 33

(D-28)

Wire colour code
 B : Black LG : Light green G : Green L : Blue W : White Y : Yellow SB : Sky blue
 BR : Brown O : Orange GR : Gray R : Red P : Pink V : Violet

HEATER

Diesel-powered vehicles

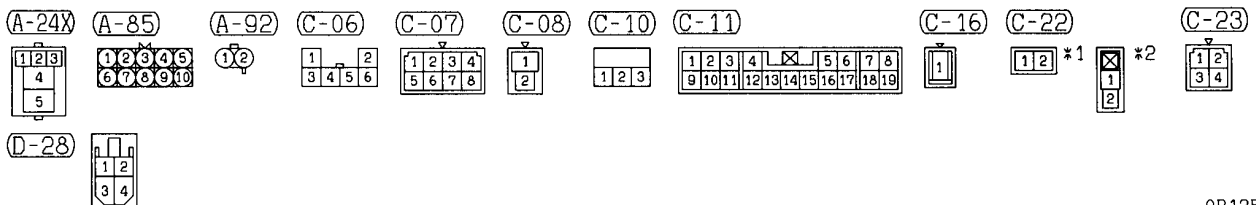
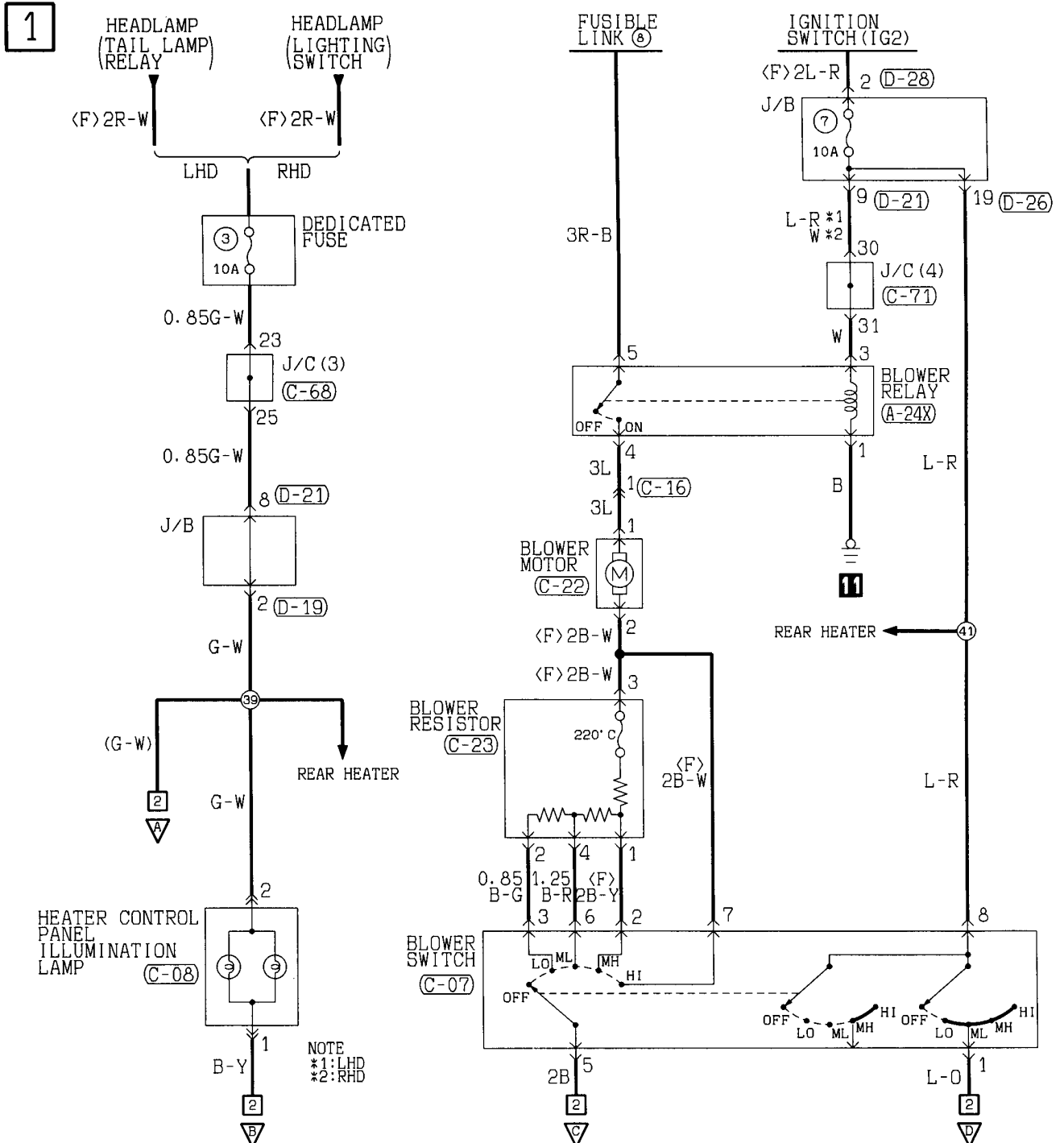

2

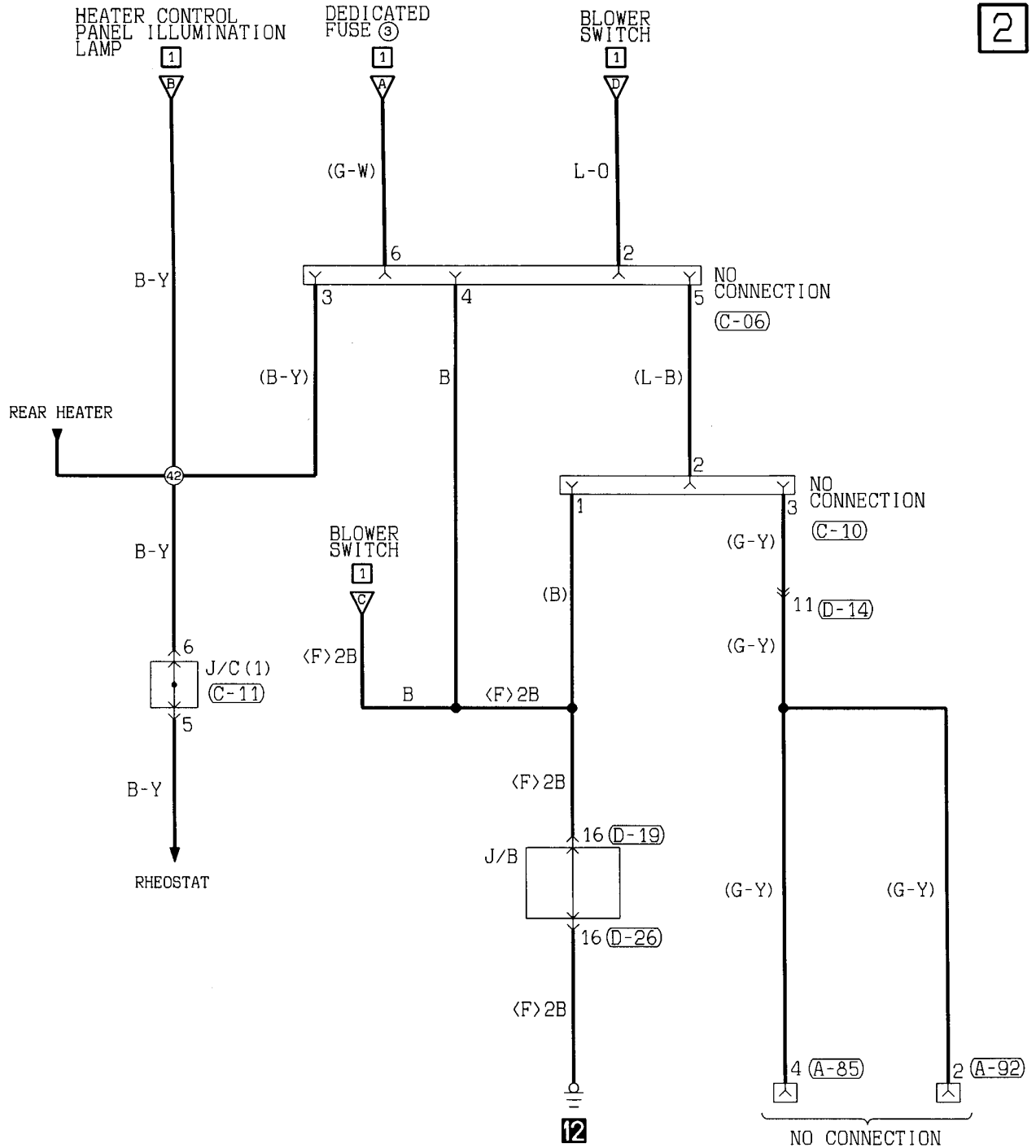

(C-68)

1	2	3	4	5	6	7	8	9	10	11
12	13	14	15	16	17	18	19	20	21	22
23	24	25	26	27	28	29	30	31	32	33

(C-71)

1	2	3	4	5	6	7	8	9	10	11
12	13	14	15	16	17	18	19	20	21	22
23	24	25	26	27	28	29	30	31	32	33

(D-14)

1	2	3	4	5	6	7	8
9	10	11	12	13	14	15	16
17	18	19					

(D-19)

1	2	3	4	5	6	7
8	9	10	11	12	13	14
15	16					

(D-21)

1	2	3	4	5
6	7	8	9	10
11	12			

(D-26)

1	2	3	4	5	6	7	8	9
10	11	12	13	14	15	16	17	18
19	20							

Wire colour code

B : Black LG : Light green G : Green L : Blue W : White Y : Yellow SB : Sky blue
 BR : Brown O : Orange GR : Gray R : Red P : Pink V : Violet

AIR CONDITIONER

Petrol-powered vehicles

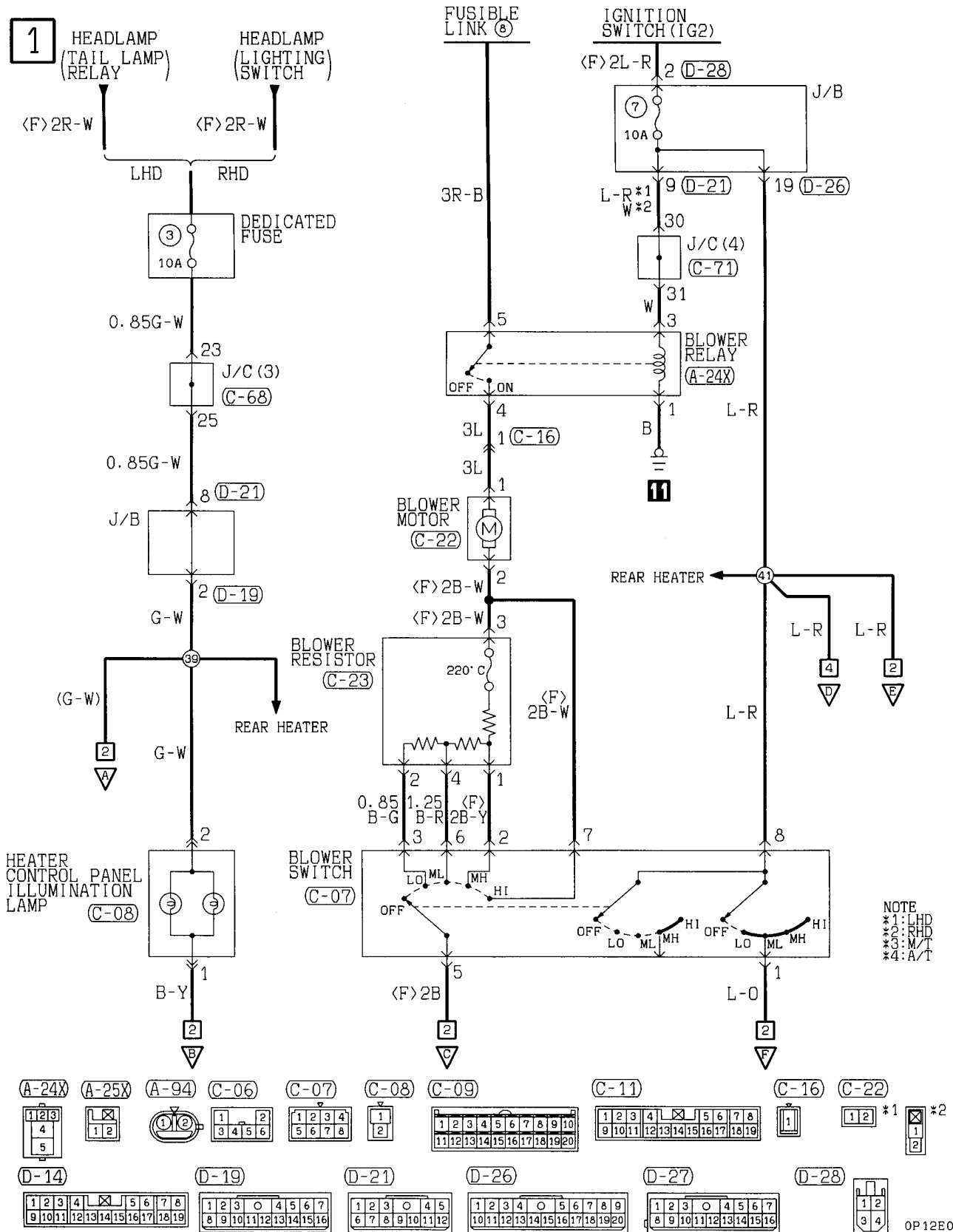

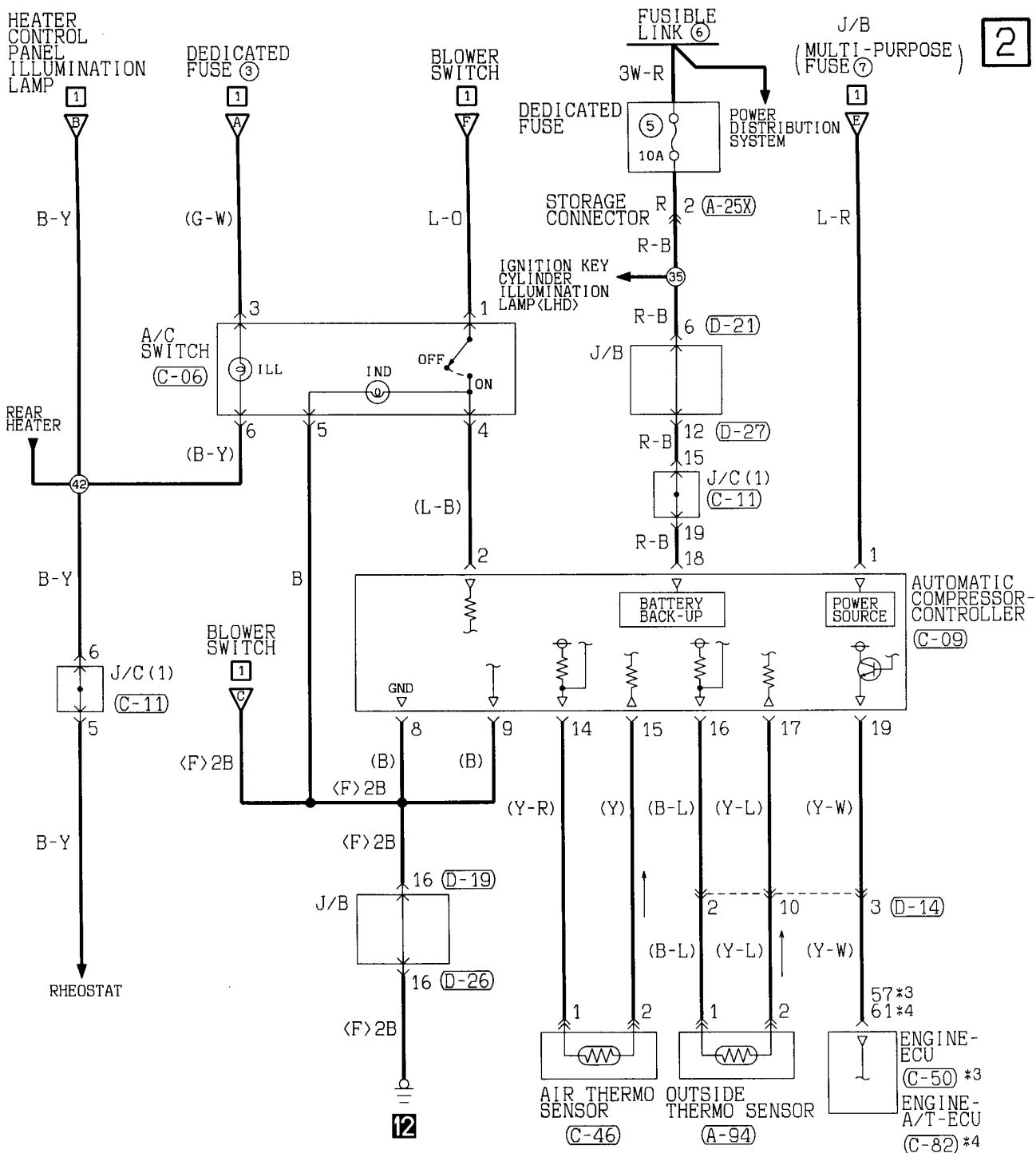

(C-23) 1 2 3 4	(C-46) 1 2	(C-50) 51 52 53 54 55 56 57 58 59 60 61 62	(C-68) 1 2 3 4 5 6 7 8 9 10 11 12 13 14 15 16 17 18 19 20 21 22 23 24 25 26 27 28 29 30 31 32 33	(C-71) 1 2 3 4 5 6 7 8 9 10 11 12 13 14 15 16 17 18 19 20 21 22 23 24 25 26 27 28 29 30 31 32 33	(C-82) 41 42 43 44 45 46 47 48 49 50 51 52 53 54 55 56 57 58 59 60 61 62 63 64 65 66
-----------------------------	-------------------------	---	--	--	--

Wire colour code
 B : Black LG : Light green G : Green L : Blue W : White Y : Yellow SB : Sky blue
 BR : Brown O : Orange GR : Gray R : Red P : Pink V : Violet

4

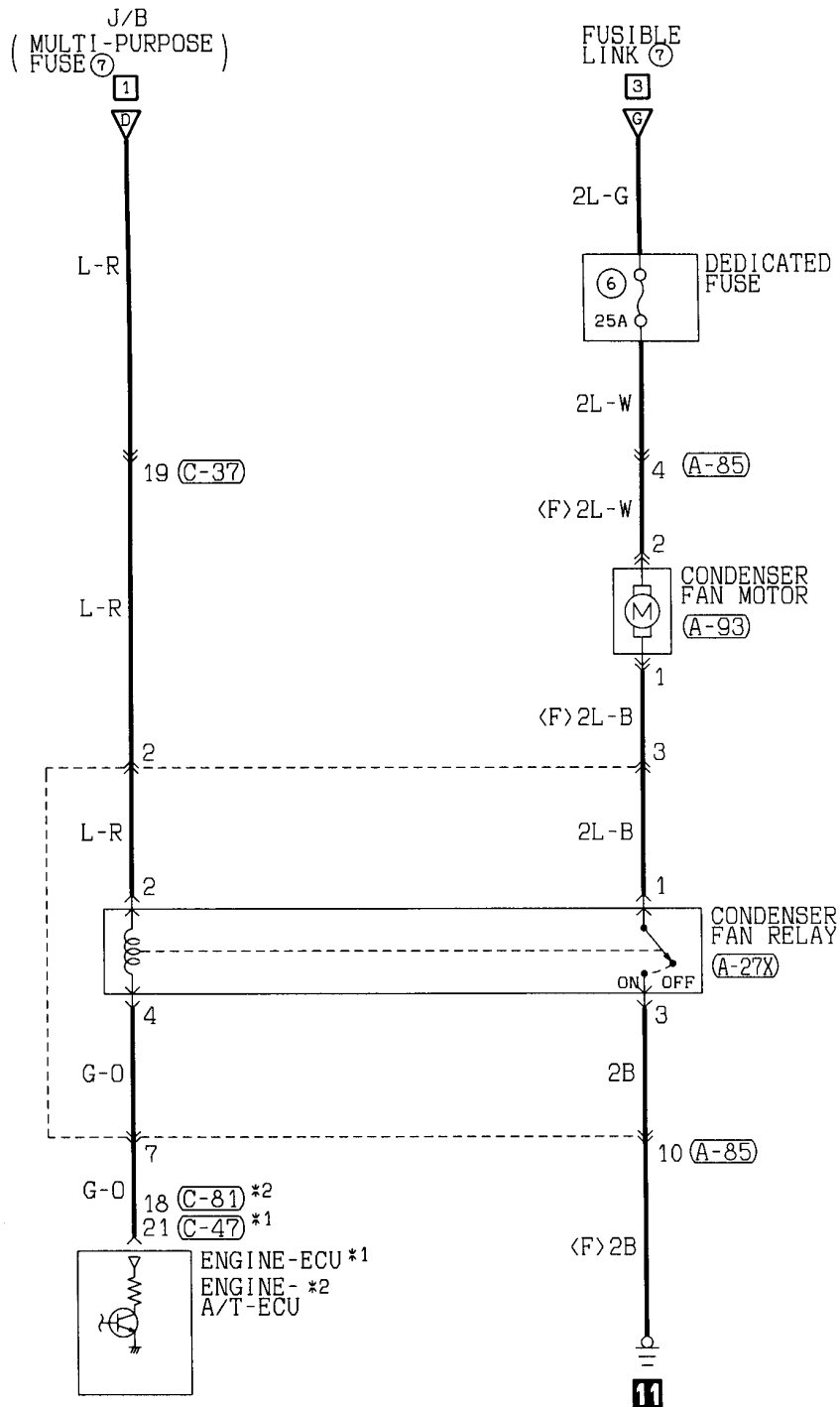

C-47

1	2	3	4	5	6	7	8	9	10	11	12	13
14	15	16	17	18	19	20	21	22	23	24	25	26

C-49

31	32	33	34	35	36	37	38
39	40	41	42	43	44	45	46

C-81

1	2	3	4	5	6	7	8							
9	10	11	12	13	14	15	16	17	18	19	20	21	22	23
24	25	26	27	28	29	30	31	32	33	34	35			

C-83

1	2	3	4	5	6	7	8							
9	10	11	12	13	14	15	16	17	18	19	20	21	22	23
24	25	26	27	28	29	30	31	32	33	34	35			

Wire colour code
 B :Black LG:Light green G:Green L:Blue W:White Y:Yellow SB:Sky blue
 BR:Brown O:Orange GR:Gray R:Red P:Pink V:Violet

AIR CONDITIONER

Diesel-powered vehicles

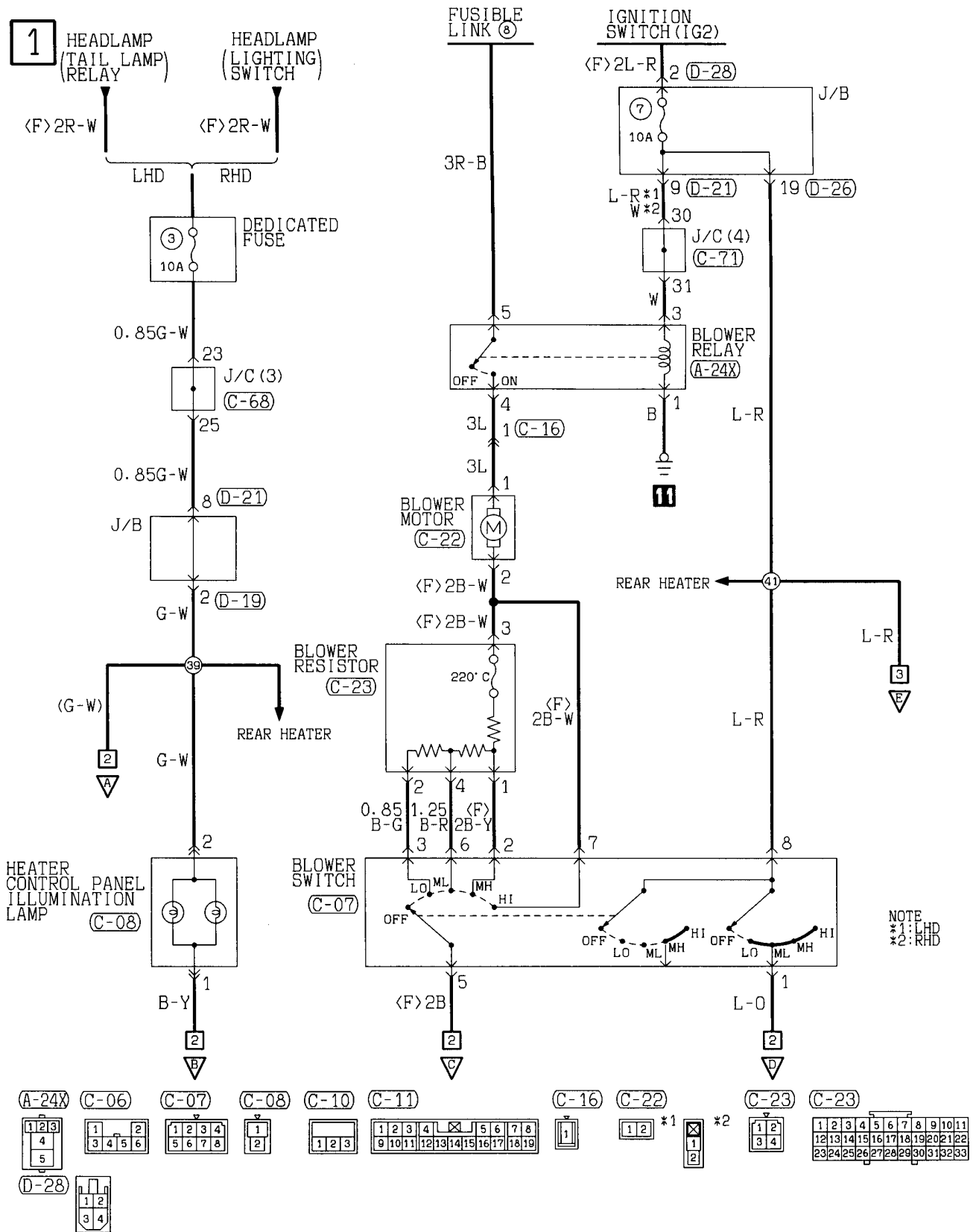

2

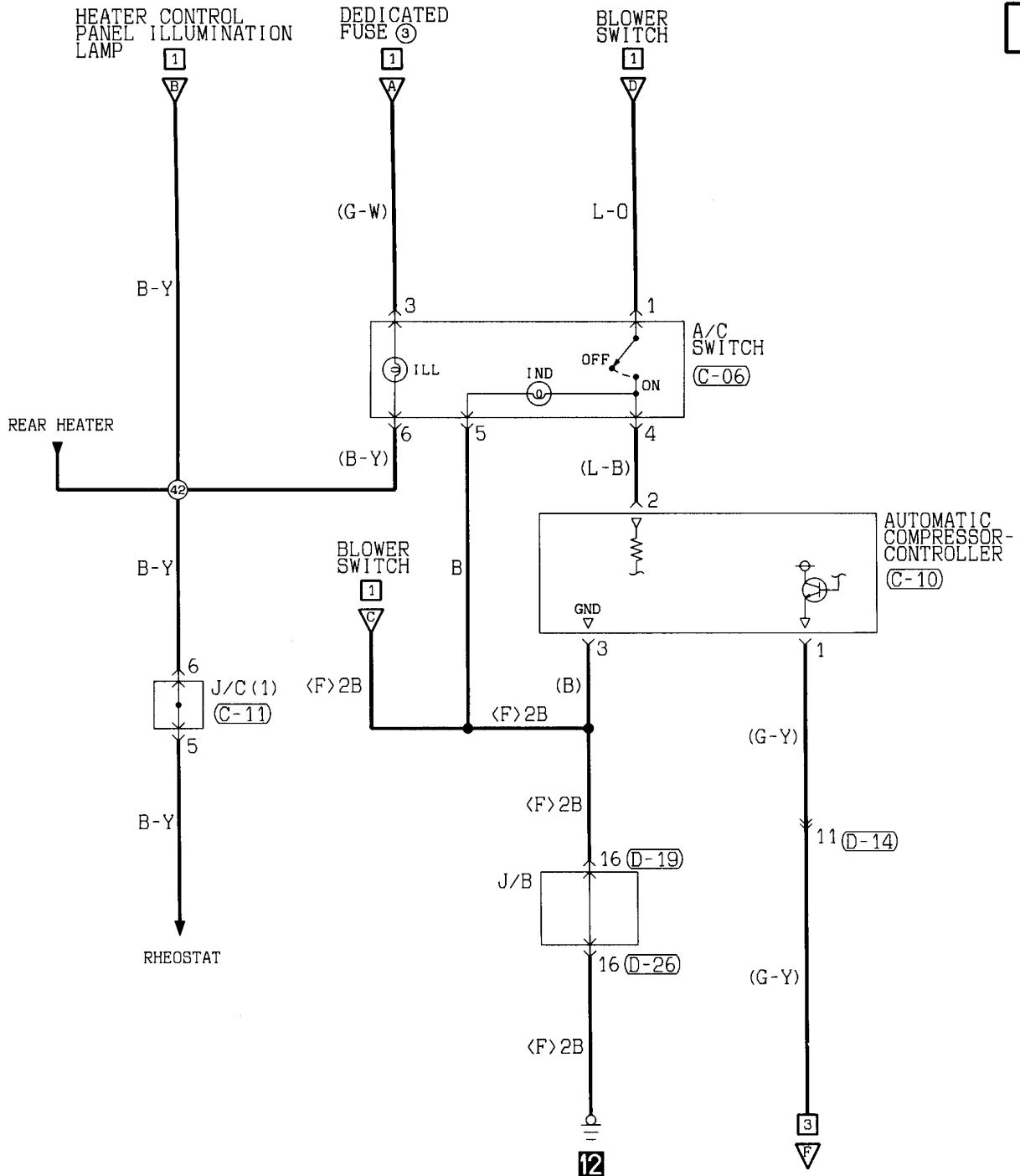

(C-68)

1	2	3	4	5	6	7	8	9	10	11
12	13	14	15	16	17	18	19	20	21	22
23	24	25	26	27	28	29	30	31	32	33

(C-71)

1	2	3	4	5	6	7	8	9	10	11
12	13	14	15	16	17	18	19	20	21	22
23	24	25	26	27	28	29	30	31	32	33

(D-14)

1	2	3	4	5	6	7	8
9	10	11	12	13	14	15	16
17	18	19					

(D-19)

1	2	3	4	5	6	7
8	9	10	11	12	13	14
15	16					

(D-21)

1	2	3	4	5
6	7	8	9	10
11	12			

(D-26)

1	2	3	4	5	6	7	8	9
10	11	12	13	14	15	16	17	18
19	20							

Wire colour code
 B : Black LG : Light green G : Green L : Blue W : White Y : Yellow SB : Sky blue
 BR : Brown O : Orange GR : Gray R : Red P : Pink V : Violet

AIR CONDITIONER <Diesel-powered vehicles> (CONTINUED)

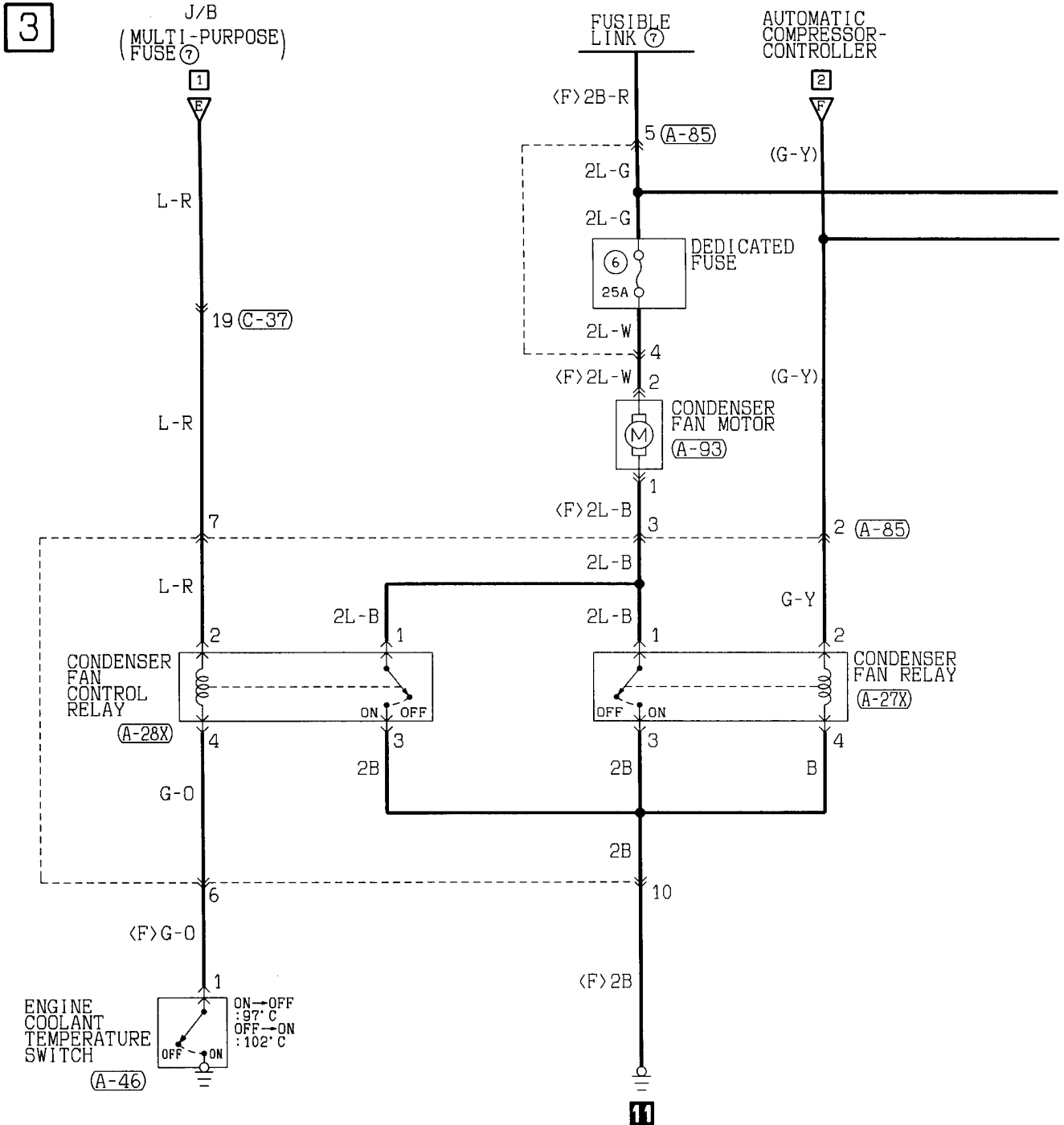

- (A-26X)

1	2
3	4
- (A-27X)

1	2
3	4
- (A-28X)

1	2
3	4
- (A-39)

1	2
3	
- (A-45)

1	2
---	---
- (A-46)

1

- (A-74)

1
2
- (A-85)

1	2	3	4	5
6	7	8	9	10
- (A-92)

1	2
---	---
- (A-93)

1	2
---	---
- (C-37)

1	2	3	4	5	6	7	8	9	10		
11	12	13	14	15	16	17	18	19	20	21	22

4

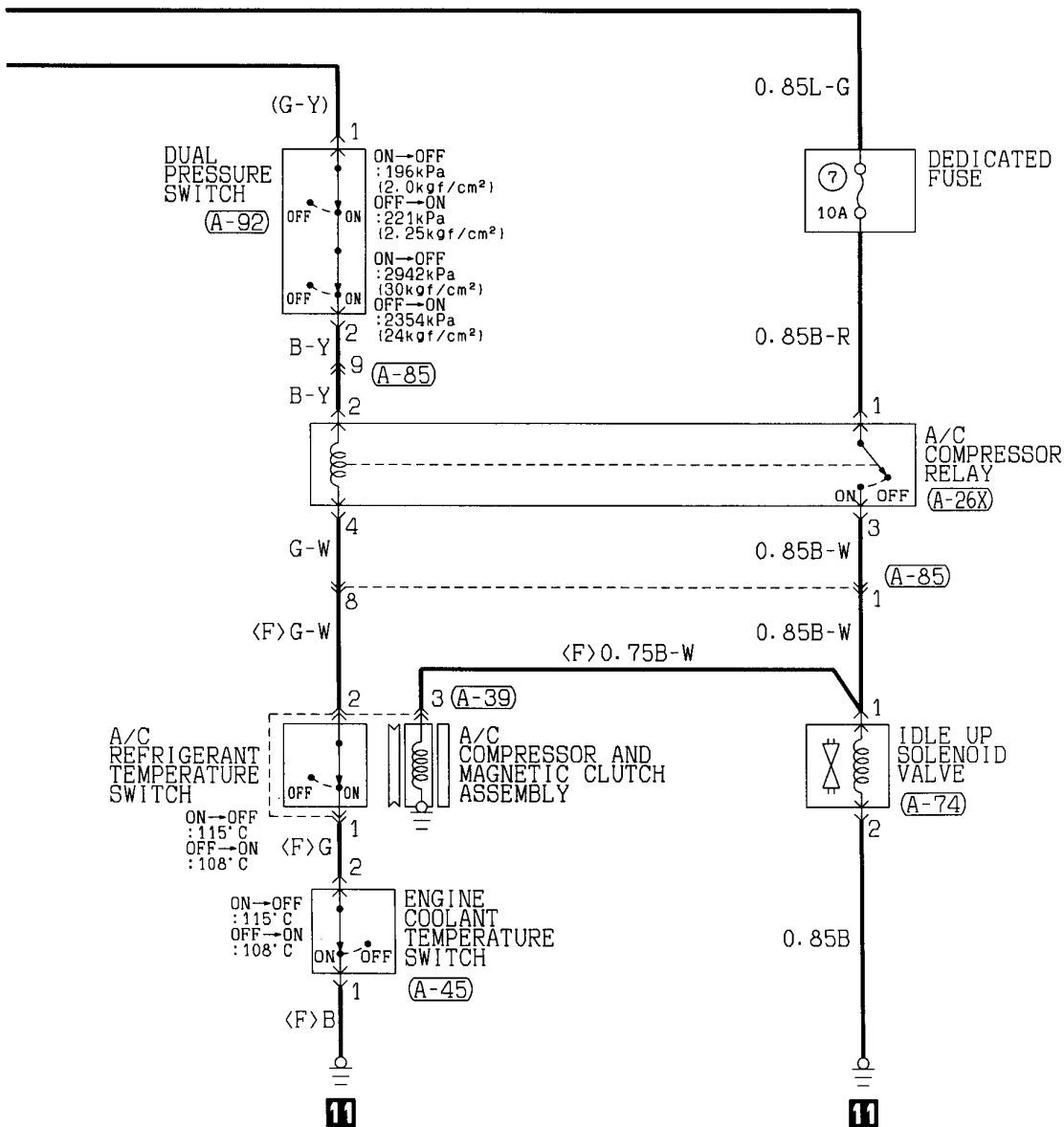

Wire colour code
 B :Black LG:Light green G :Green L :Blue W :White Y :Yellow SB:Sky blue
 BR:Brown O :Orange GR:Gray R :Red P :Pink V :Violet

REAR HEATER

1

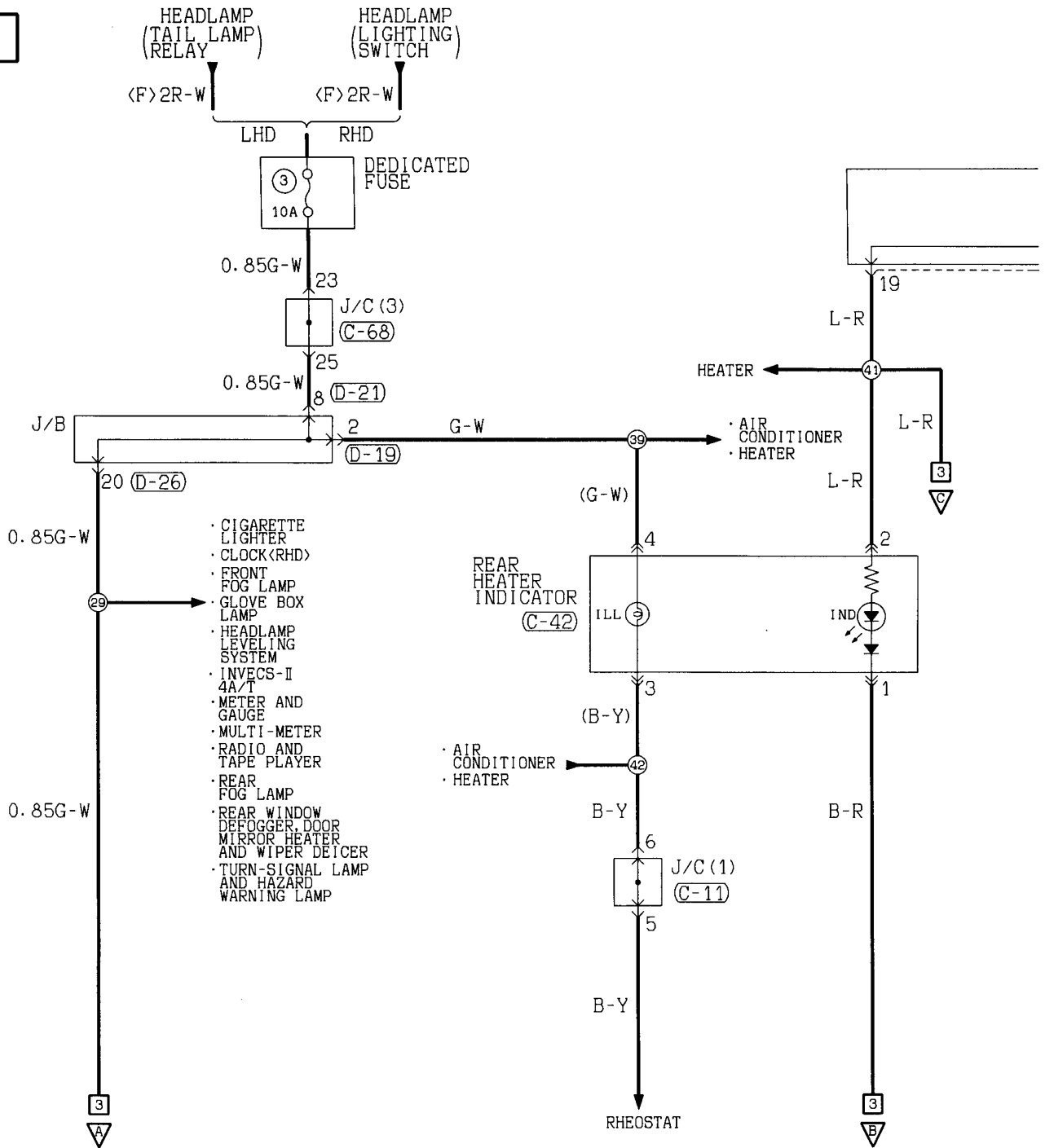

(C-11)

1	2	3	4	5	6	7	8			
9	10	11	12	13	14	15	16	17	18	19

(C-37)

1	2	3	4	5	6	7	8	9	10		
11	12	13	14	15	16	17	18	19	20	21	22

(C-42)

M			
1	2	3	4

(C-68)

1	2	3	4	5	6	7	8	9	10	11
12	13	14	15	16	17	18	19	20	21	22
23	24	25	26	27	28	29	30	31	32	33

(D-15X)

1	2
3	4

(D-19)

1	2	3	4	5	6	7		
8	9	10	11	12	13	14	15	16

(D-21)

1	2	3	4	5		
6	7	8	9	10	11	12

2

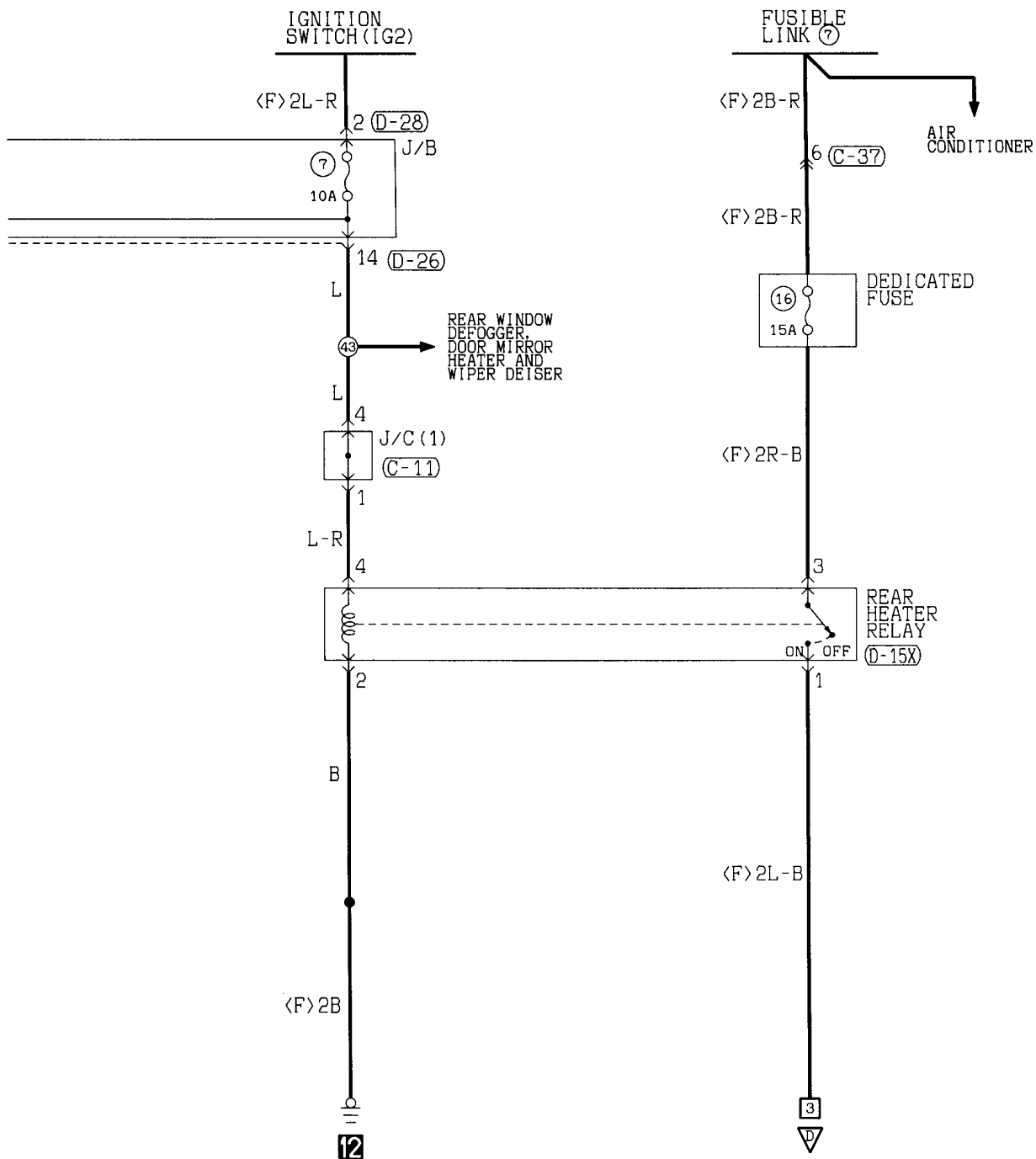

(D-26)

1	2	3	4	5	6	7	8	9		
10	11	12	13	14	15	16	17	18	19	20

(D-28)

1	2
3	4

Wire colour code
 B :Black LG:Light green G :Green L :Blue W :White Y :Yellow SB:Sky blue
 BR:Brown O :Orange GR:Gray R :Red P :Pink V :Violet

REAR HEATER (CONTINUED)

3

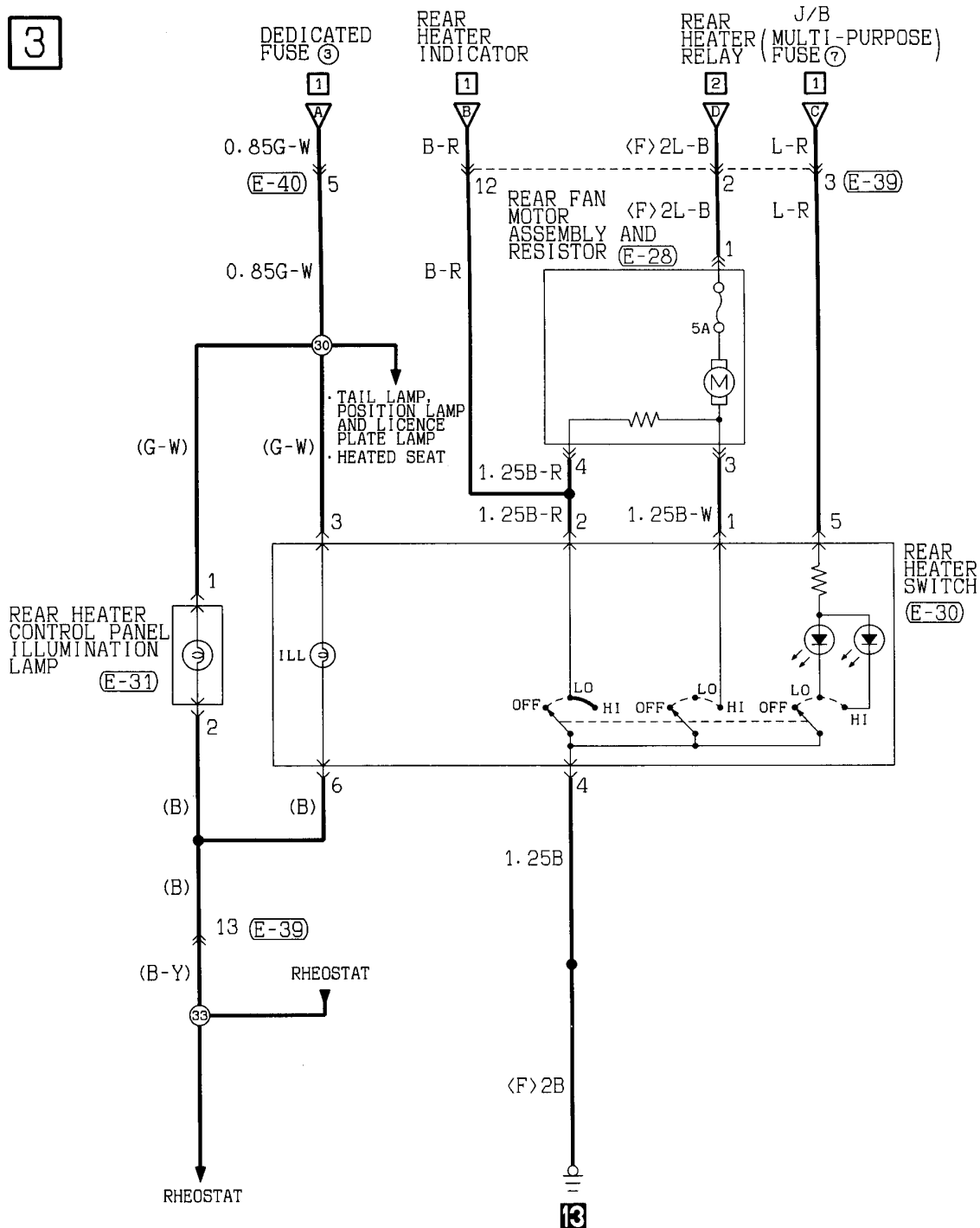

(E-28)	(E-30)	(E-31)	(E-39)	(E-40)

Wire colour code
 B :Black LG:Light green G :Green L :Blue W :White Y :Yellow SB:Sky blue
 BR:Brown O :Orange GR:Gray R :Red P :Pink V :Violet

NOTES

REAR WIPER AND WASHER

1

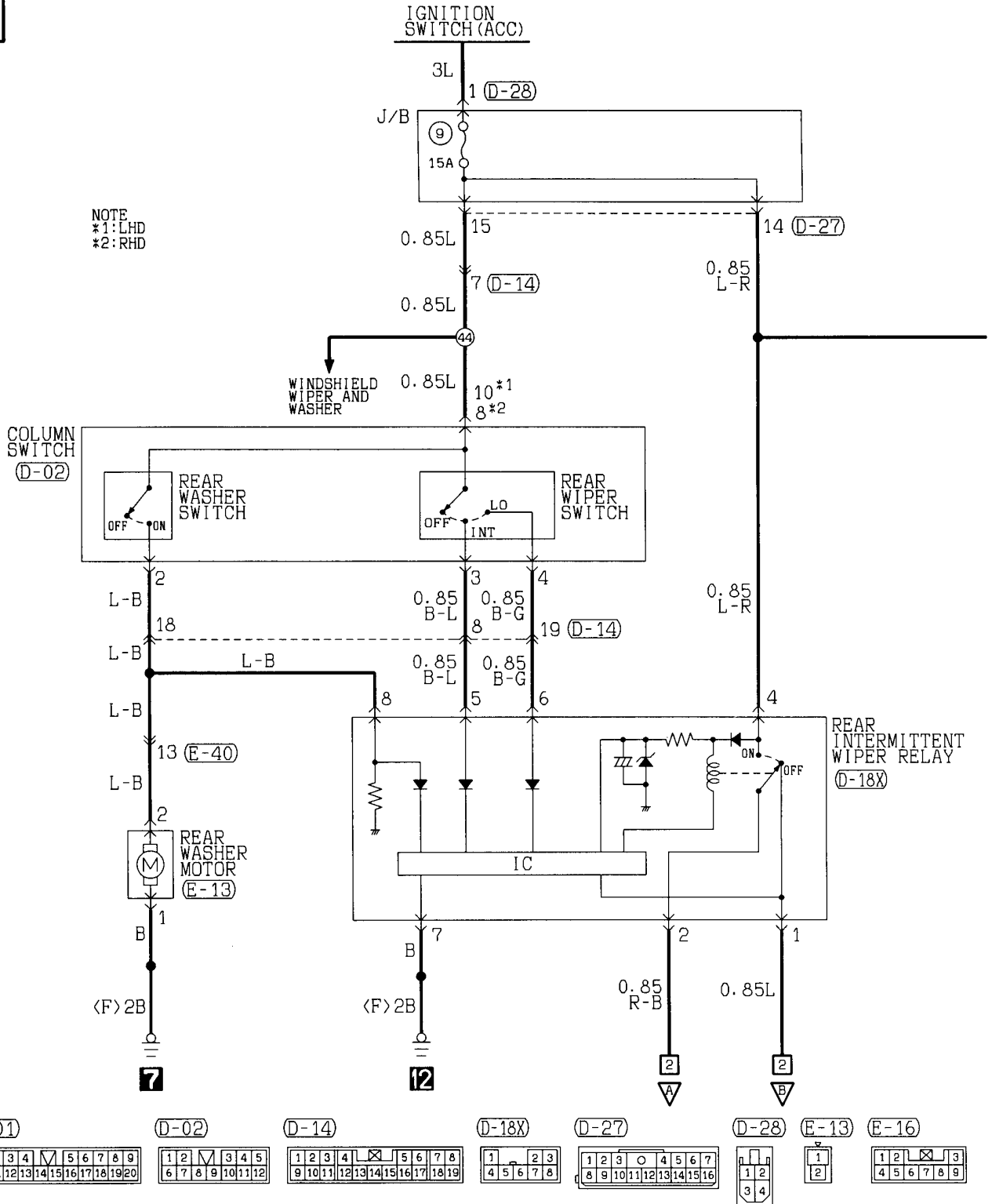

2

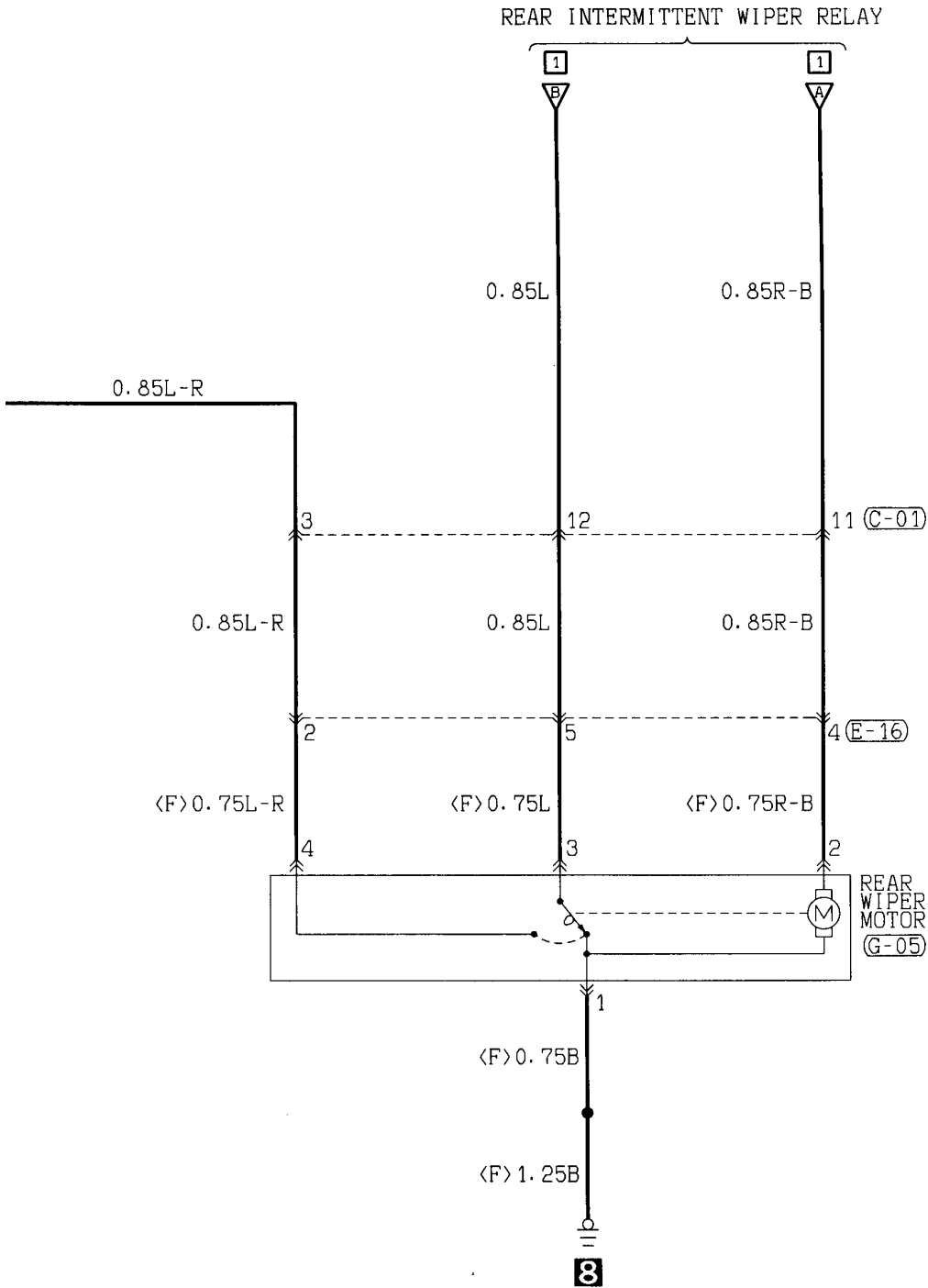

(E-40)

(G-05)

1	2	3	4	5	6	7	8
9	10	11	12	13	14	15	16
17	18	19					

1	2	3	4
---	---	---	---

Wire colour code
 B : Black LG:Light green G :Green L :Blue W :White Y :Yellow SB:Sky blue
 BR:Brown O :Orange GR:Gray R :Red P :Pink V :Violet

HEADLAMP WASHER

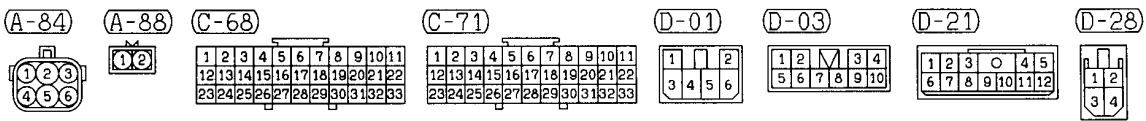
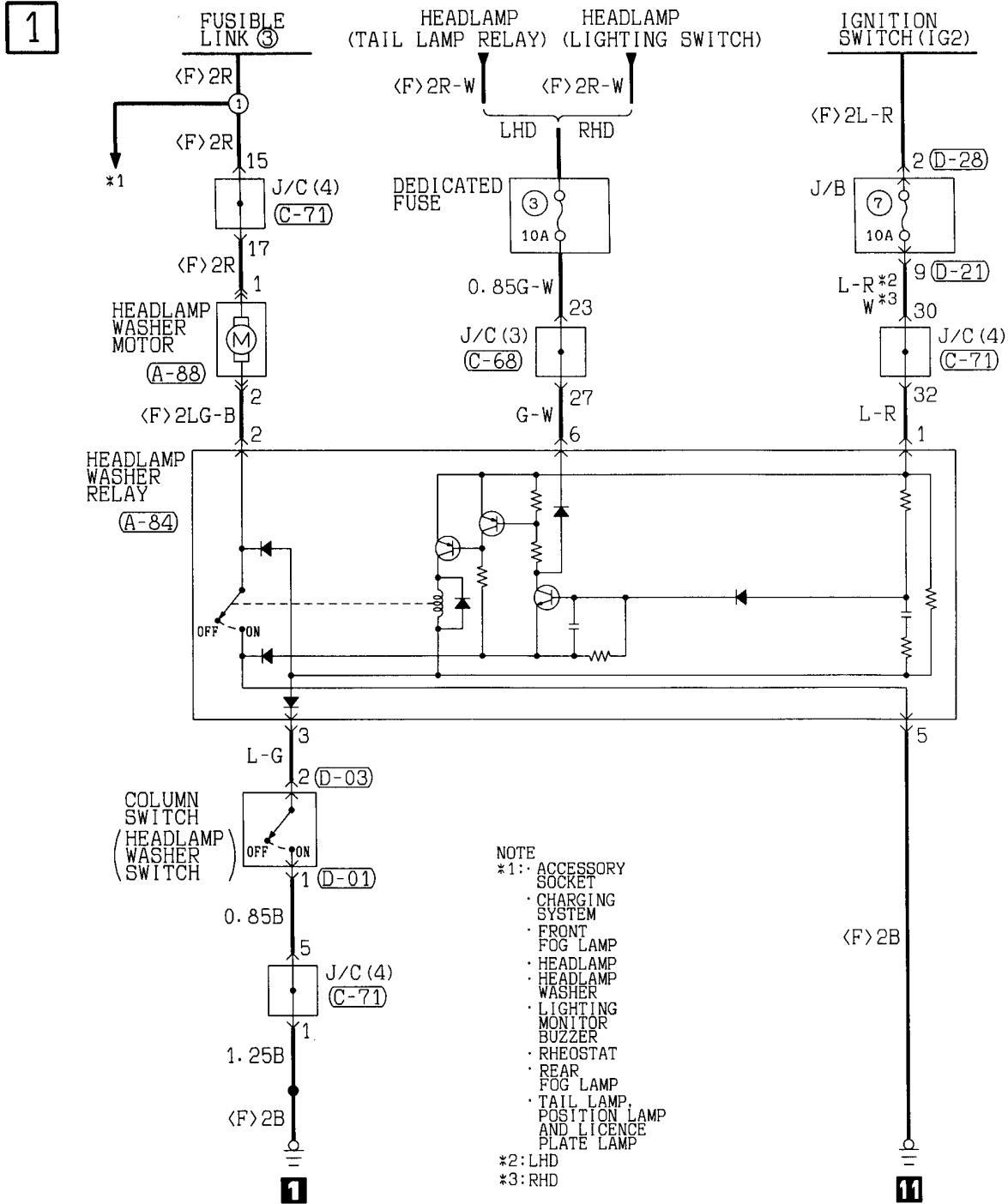

Wire colour code
 B:Black LG:Light green G:Green L:Blue W:White Y:Yellow SB:Sky blue
 BR:Brown O:Orange GR:Gray R:Red P:Pink V:Violet

NOTES

RADIO AND TAPE PLAYER

1

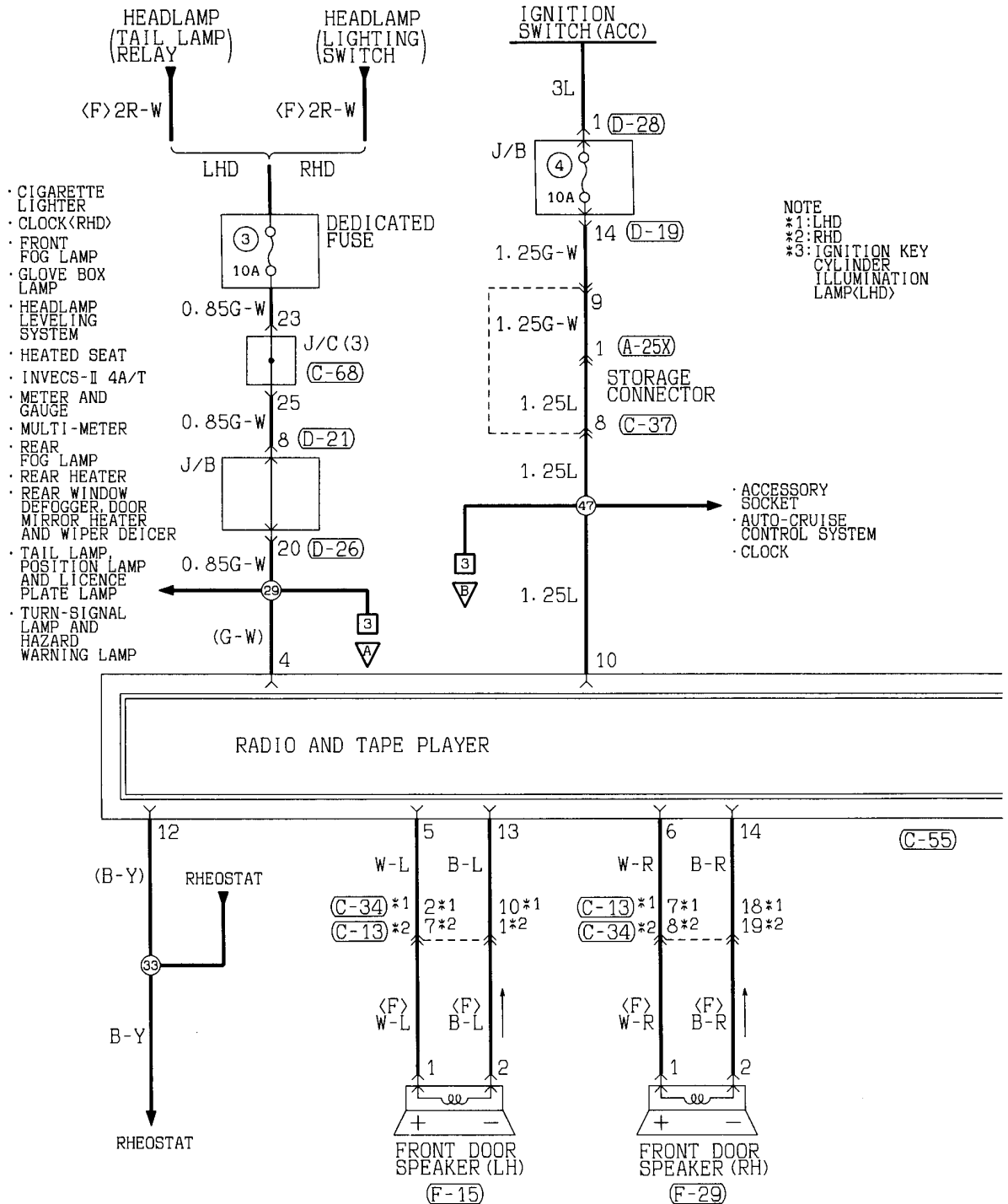

NOTE
 *1: LHD
 *2: RHD
 *3: IGNITION KEY
 CYLINDER
 ILLUMINATION
 LAMP(LHD)

· ACCESSORY
 SOCKET
 · AUTO-CRUISE
 CONTROL SYSTEM
 · CLOCK

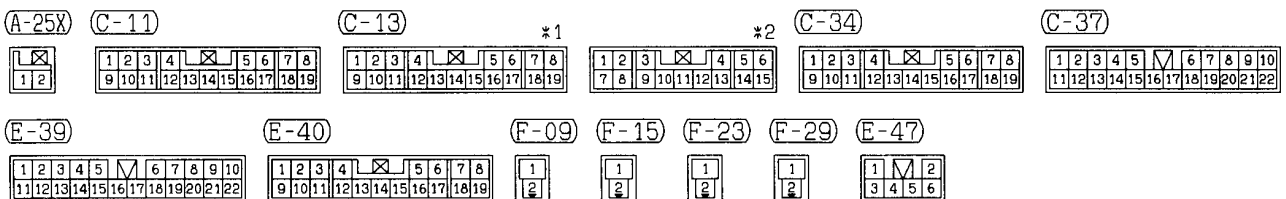

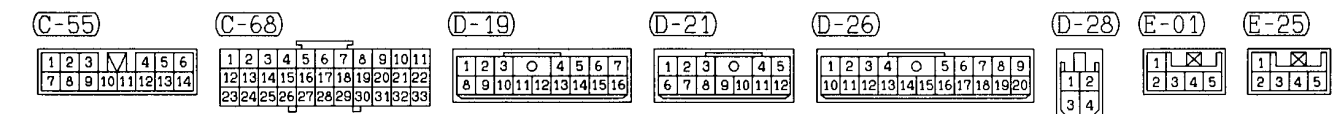
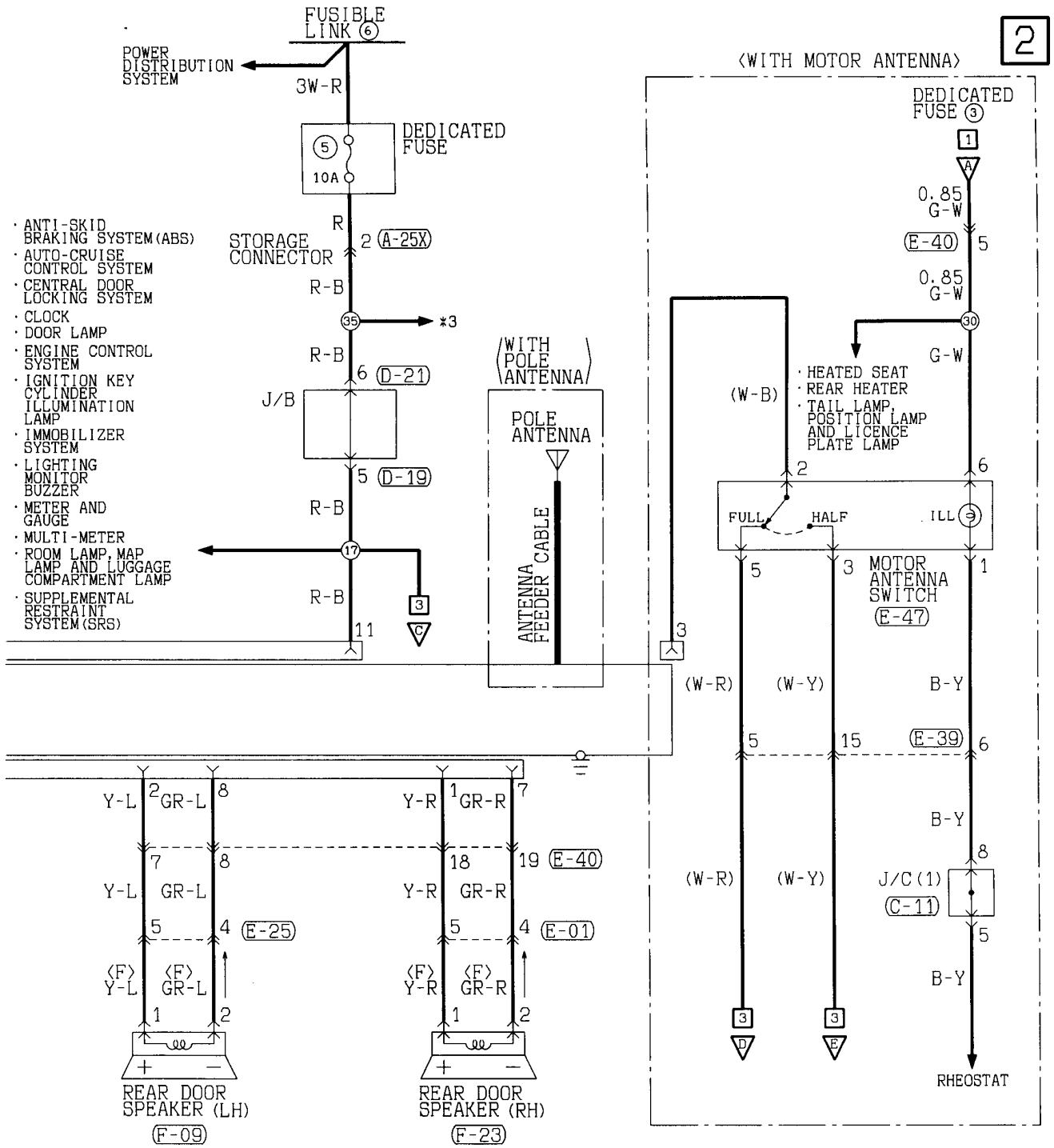

Wire colour code
 B :Black LG:Light green G :Green L :Blue W :White Y :Yellow SB:Sky blue
 BR:Brown O :Orange GR:Gray R :Red P :Pink V :Violet

RADIO AND TAPE PLAYER (CONTINUED)

3

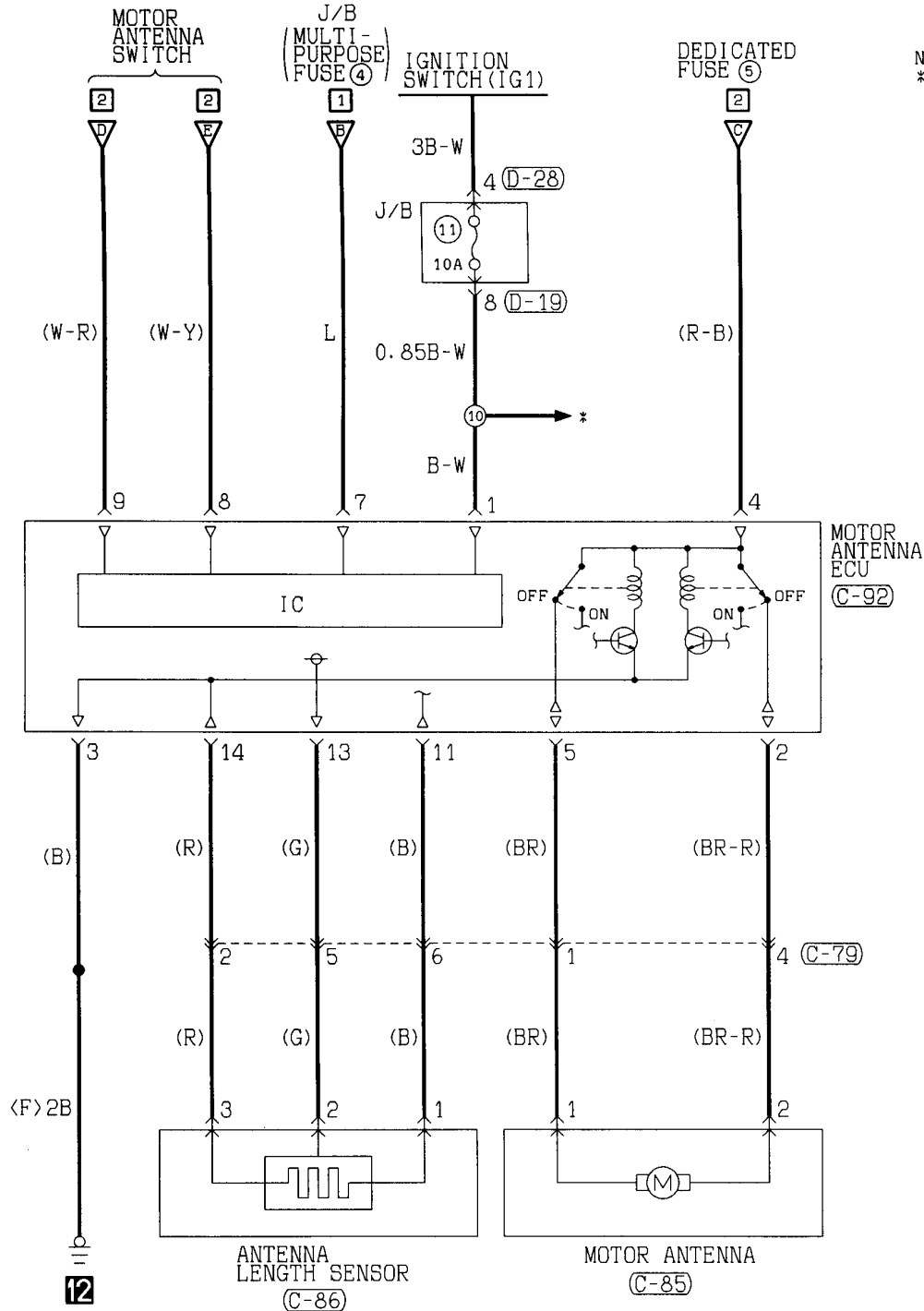

- NOTE
- *: ANTI-SKID BRAKING SYSTEM (ABS)
 - AUTO-CRUISE CONTROL SYSTEM
 - BRAKE WARNING LAMP
 - CHARGING SYSTEM
 - ENGINE CONTROL SYSTEM
 - ENGINE OIL LEVEL WARNING LAMP
 - FUEL FILTER WARNING LAMP
 - FUEL WARNING LAMP
 - GLOW SYSTEM
 - INTERCOOLER FAN
 - INVECS-II 4A/T
 - METER AND GAUGE
 - OIL PRESSURE WARNING LAMP
 - PART TIME 4WD SYSTEM
 - REAR WINDOW DEFOGGER, DOOR MIRROR HEATER AND WIPER DEICER
 - SUPPLEMENTAL RESTRAINT SYSTEM (GRS)

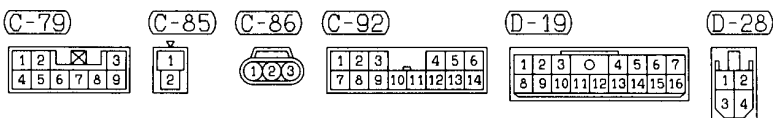

Wire colour code
 B:Black LG:Light green G:Green L:Blue W:White Y:Yellow SB:Sky blue
 BR:Brown O:Orange GR:Gray R:Red P:Pink V:Violet

ACCESSORY SOCKET

1

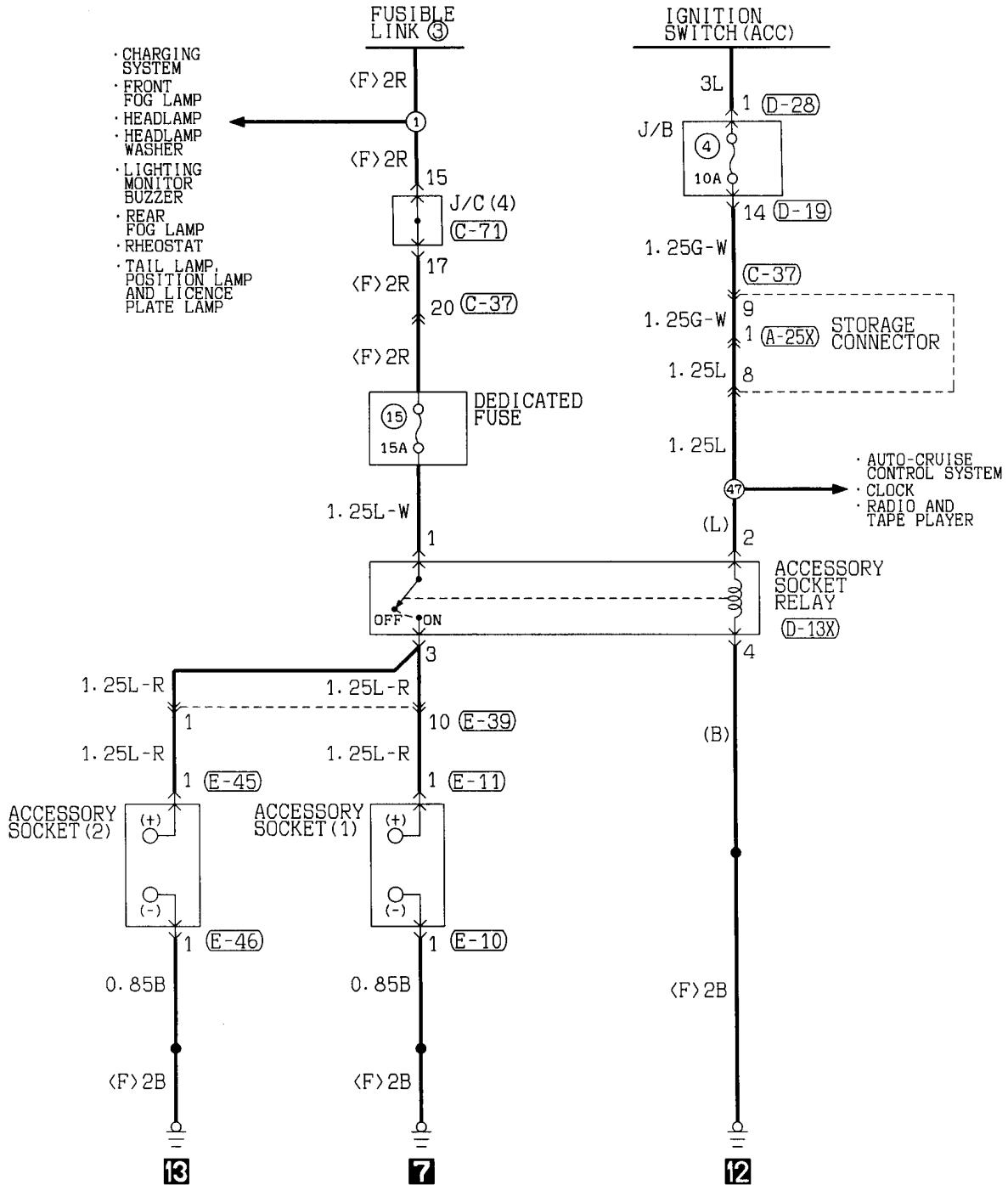

(A-25X)	(C-37)	(C-71)	(D-13X)	(D-19)	(D-28)	(E-10)	(E-11)	
(E-39)	(E-45)	(E-46)	Wire colour code					
			B : Black	LG : Light green	G : Green	L : Blue		
			BR : Brown	O : Orange	GR : Gray	R : Red		
			W : White	SB : Sky blue	P : Pink	Y : Yellow		
			V : Violet					

ANTI-SKID BRAKING SYSTEM (ABS)

1

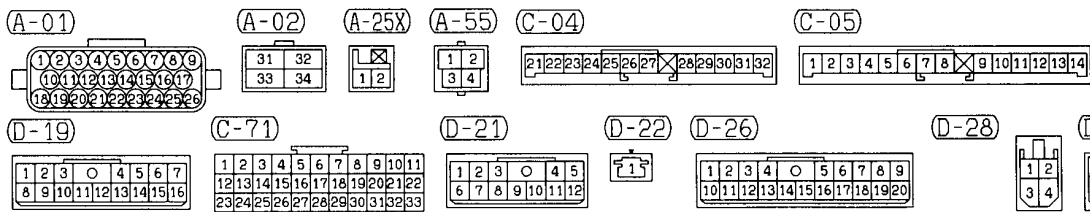
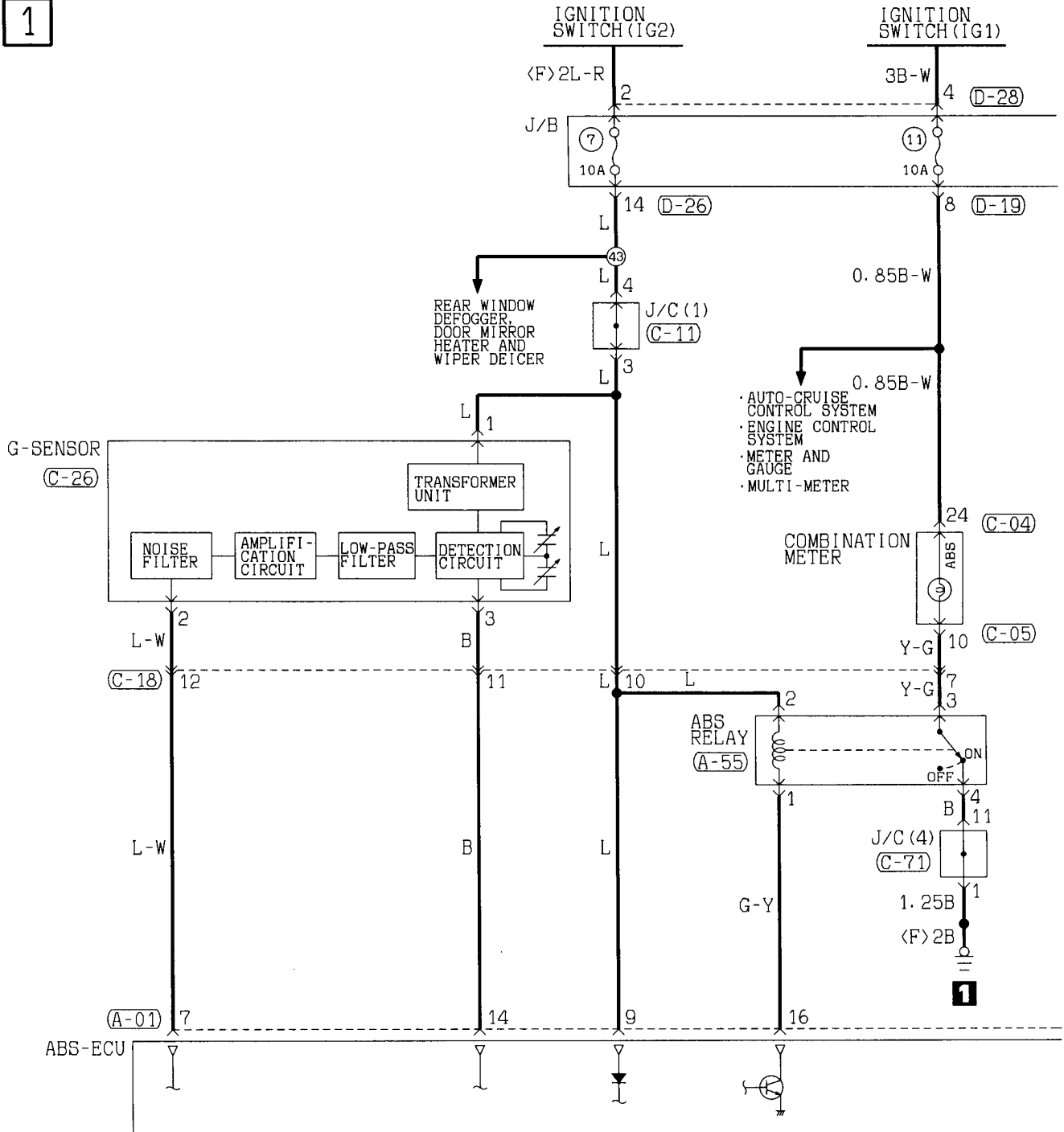

2

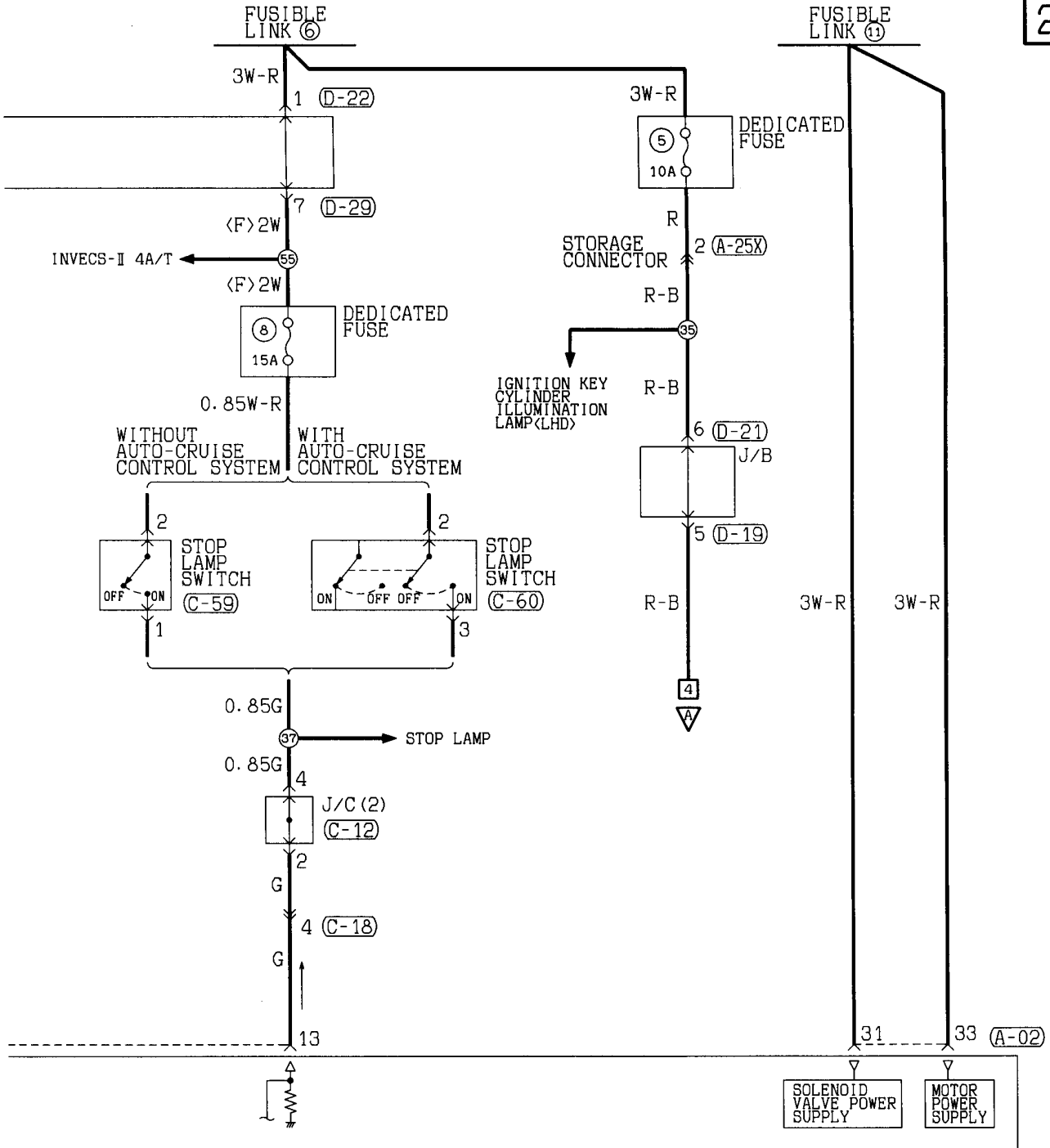

(C-11)

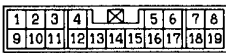

(C-12)

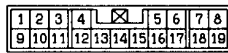

(C-18)

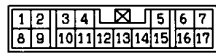

(C-26)



(C-59)



(C-60)



(C-68)

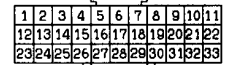

Wire colour code

B:Black LG:Light green G:Green L:Blue W:White Y:Yellow SB:Sky blue
 BR:Brown O:Orange GR:Gray R:Red P:Pink V:Violet

ANTI-SKID BRAKING SYSTEM (CONTINUED)

3

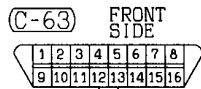
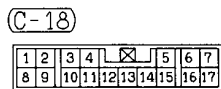
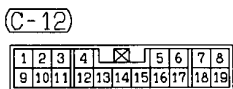
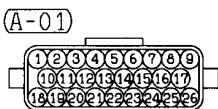
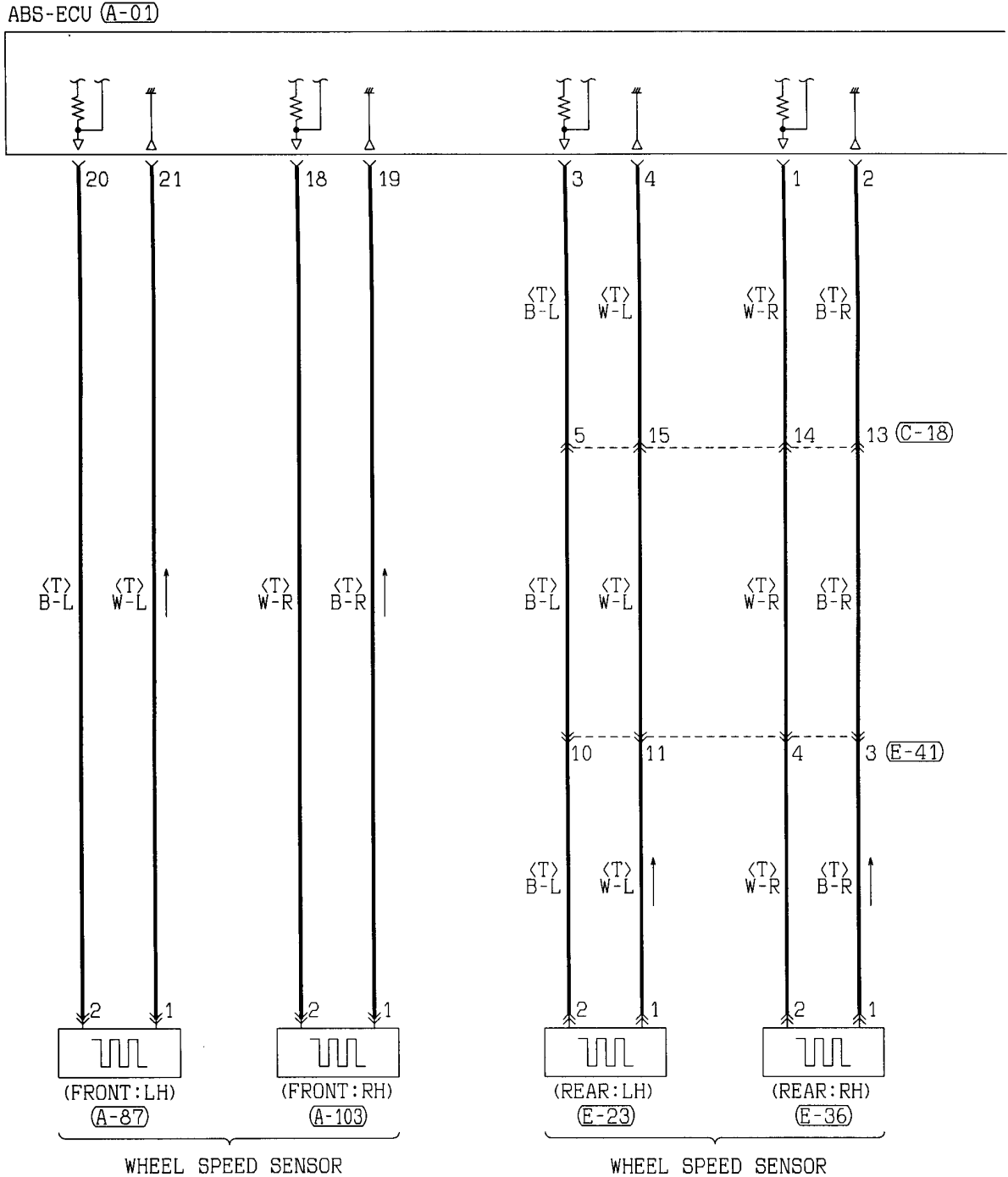

4

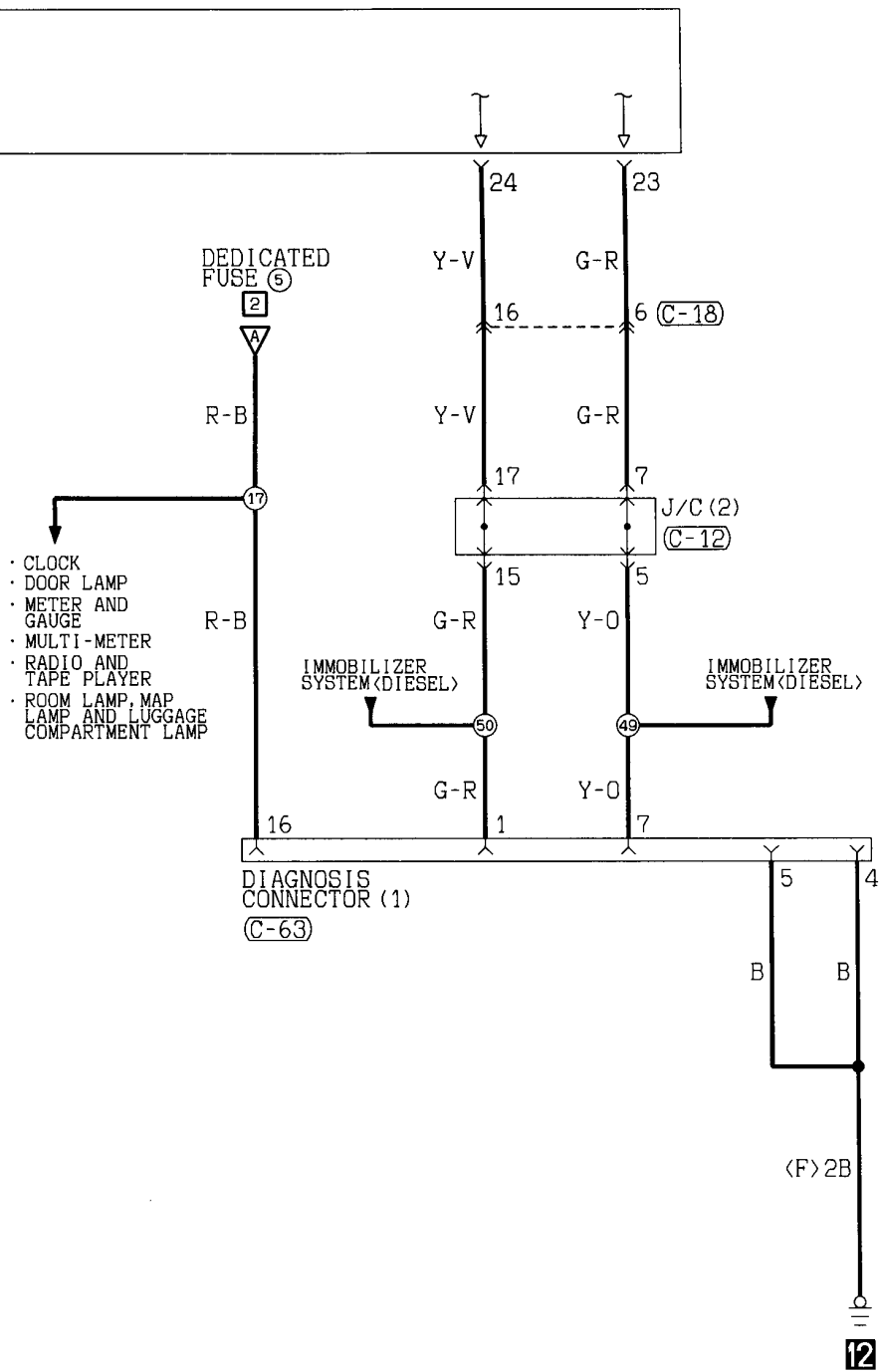

- CLOCK
- DOOR LAMP
- METER AND GAUGE
- MULTI-METER
- RADIO AND TAPE PLAYER
- ROOM LAMP, MAP LAMP AND LUGGAGE COMPARTMENT LAMP

E-41

1	2	3	0	4	5	6	7	
8	9	10	11	12	13	14	15	16

Wire color code
 B : Black LG : Light green G : Green L : Blue W : White Y : Yellow SB : Sky blue
 BR : Brown O : Orange GR : Gray R : Red P : Pink V : Violet

ANTI-SKID BRAKING SYSTEM (CONTINUED)

5

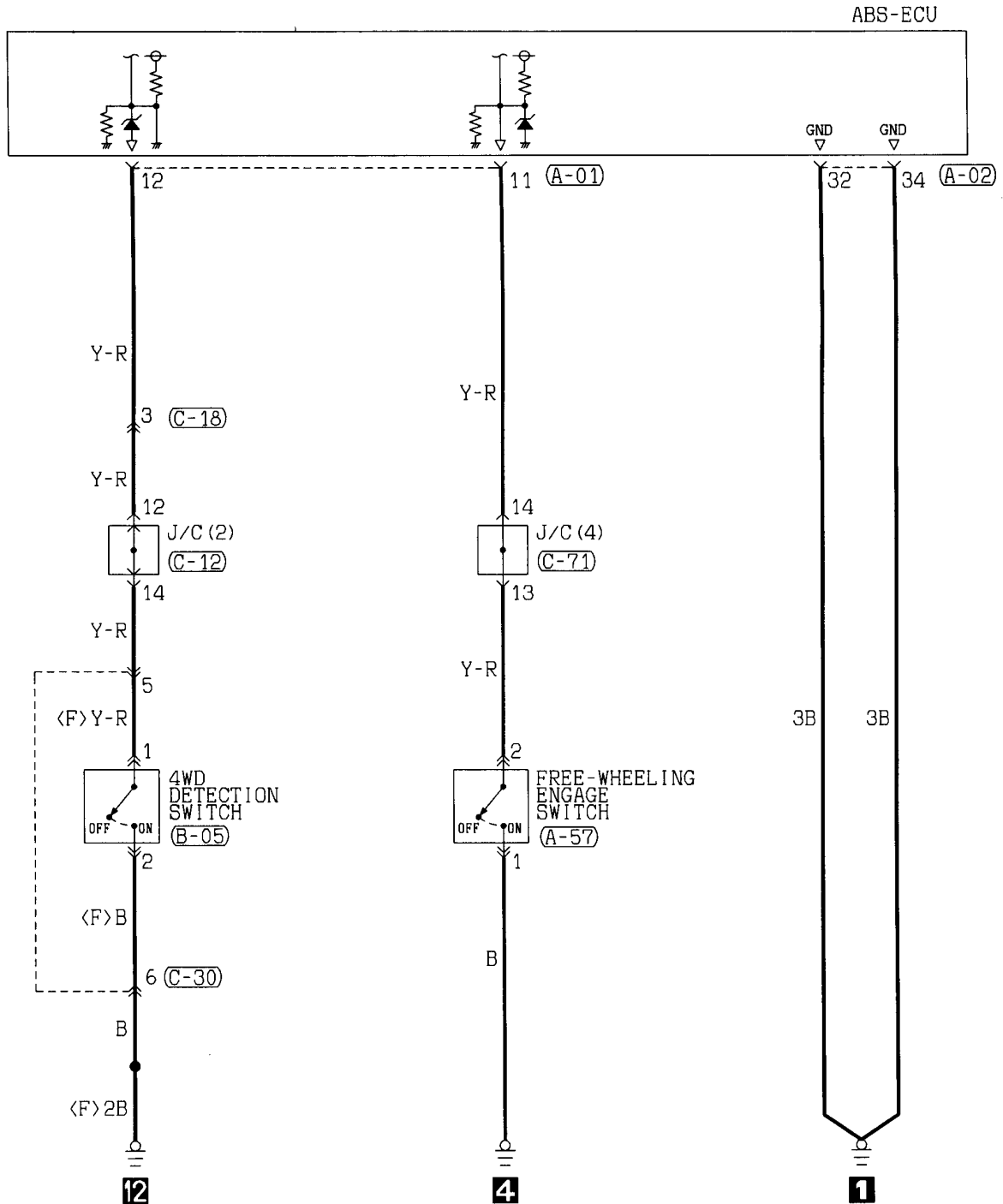

(A-01)

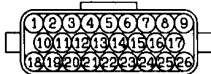

(A-02)



(A-57)



(B-05)



(C-12)

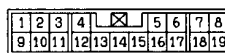

(C-18)

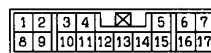

(C-30)

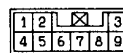

(C-71)



Wire colour code
 B : Black
 BR : Brown
 W : White
 V : Violet

code
 LG : Light green
 O : Orange
 SB : Sky blue

G : Green
 GR : Gray
 P : Pink

L : Blue
 R : Red
 Y : Yellow

NOTES

SUPPLEMENTAL RESTRAINT SYSTEM (SRS)

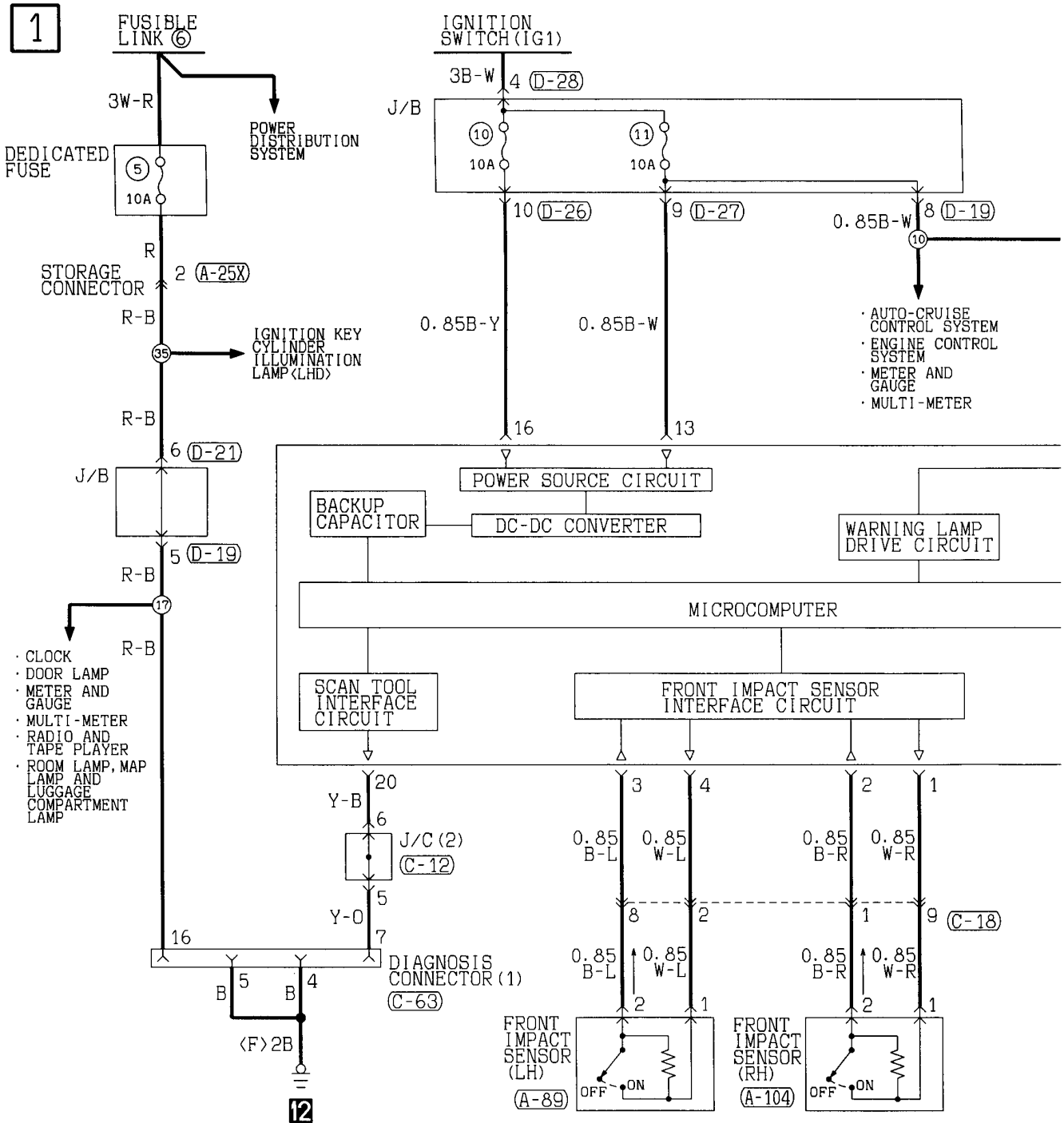

(A-25X) (A-89) (A-104) (C-03)



(C-04)

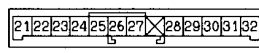

(C-12)

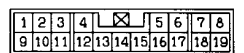

(C-18)

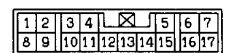

(D-26)

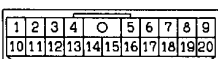

(D-27)

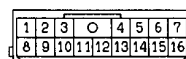

(D-28)



2

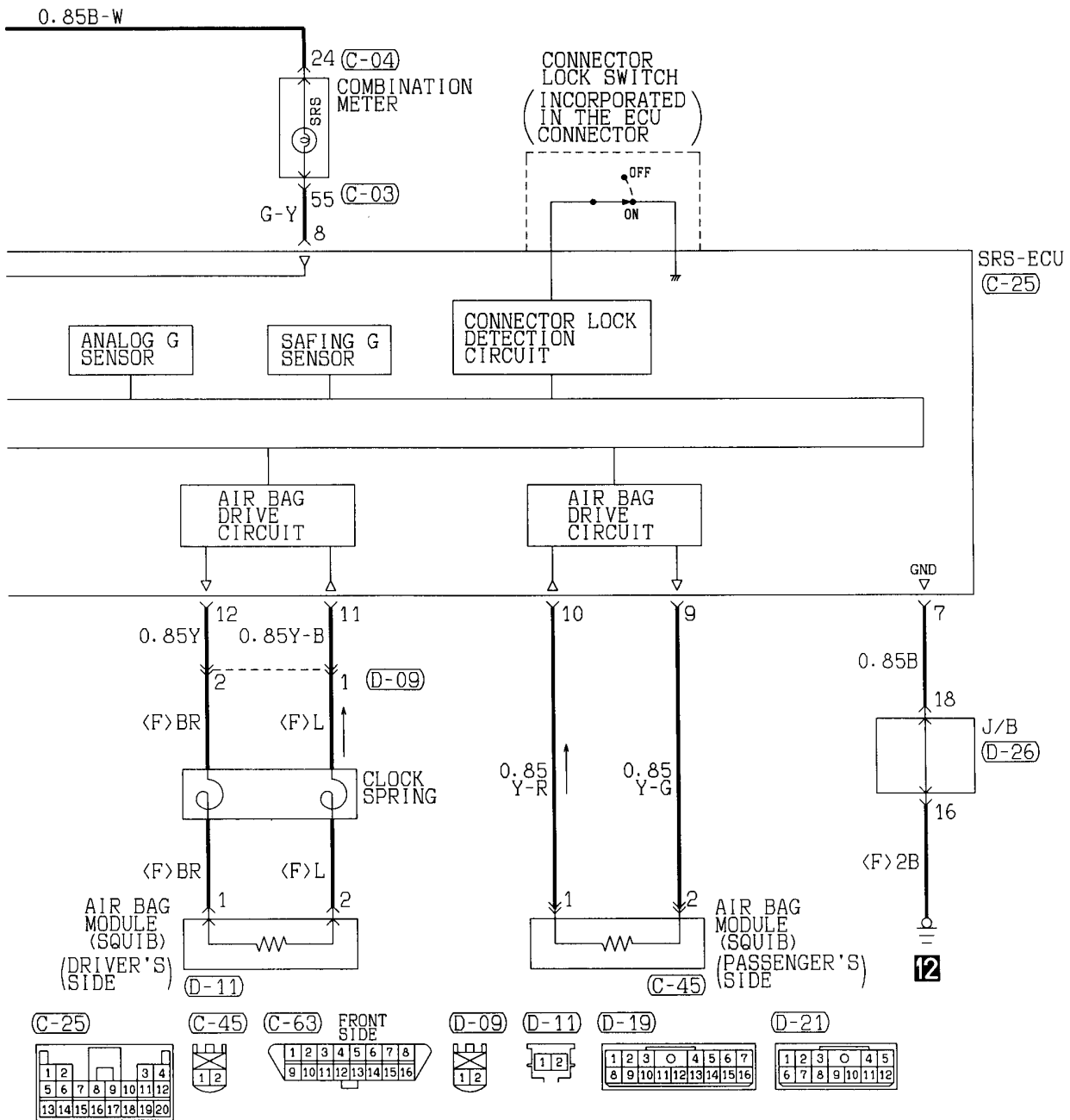

Wire colour code
 B :Black LG:Light green G:Green L :Blue W :White Y :Yellow SB:Sky blue
 BR:Brown O :Orange GR:Gray R :Red P :Pink V :Violet

AUTO-CRUISE CONTROL SYSTEM

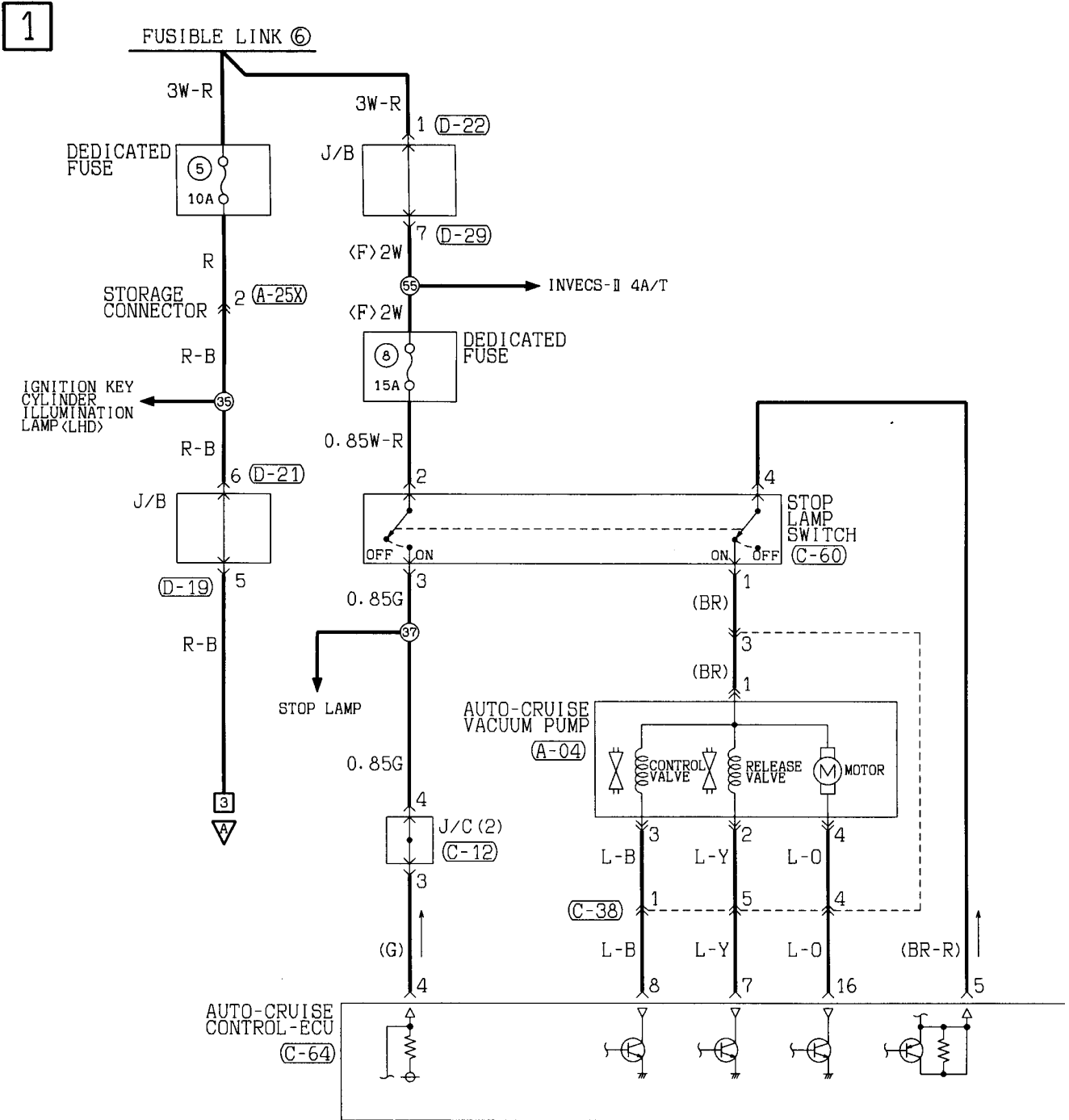

A-04

1	2
3	4

A-25X

1	2
---	---

C-04

21	22	23	24	25	26	27	28	29	30	31	32
----	----	----	----	----	----	----	----	----	----	----	----

C-05

1	2	3	4	5	6	7	8	9	10	11	12	13	14
---	---	---	---	---	---	---	---	---	----	----	----	----	----

C-12

1	2	3	4	5	6	7	8			
9	10	11	12	13	14	15	16	17	18	19

C-37

1	2	3	4	5	6	7	8	9	10		
11	12	13	14	15	16	17	18	19	20	21	22

2

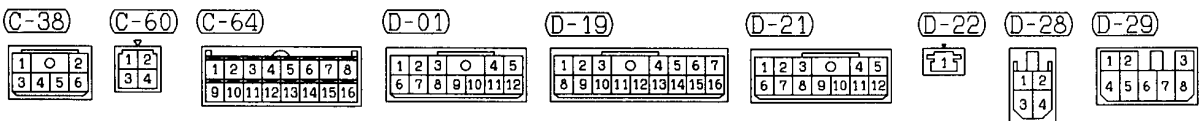
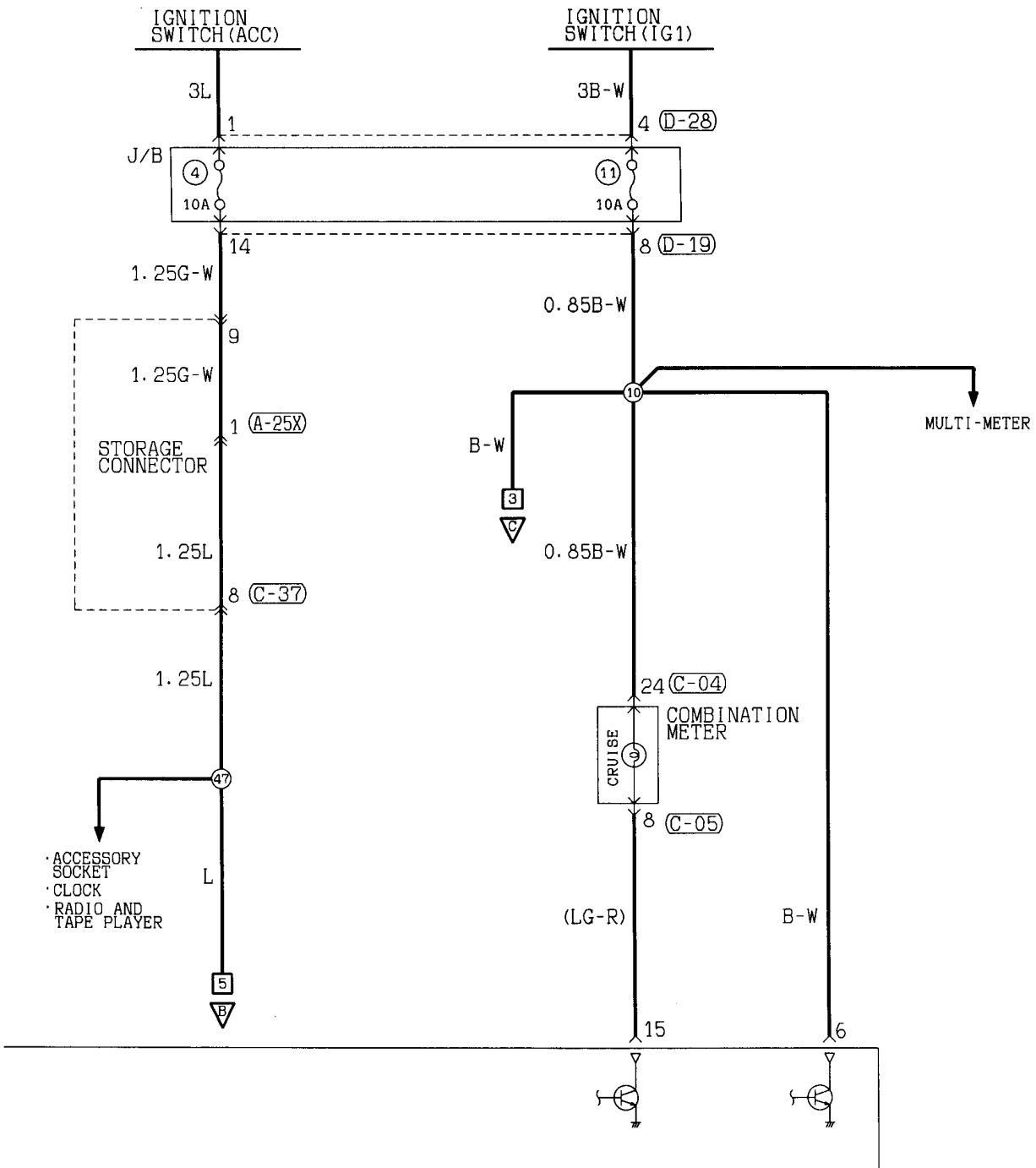

Wire colour code
 B:Black LG:Light green G:Green L:Blue W:White Y:Yellow SB:Sky blue
 BR:Brown O:Orange GR:Gray R:Red P:Pink V:Violet

4

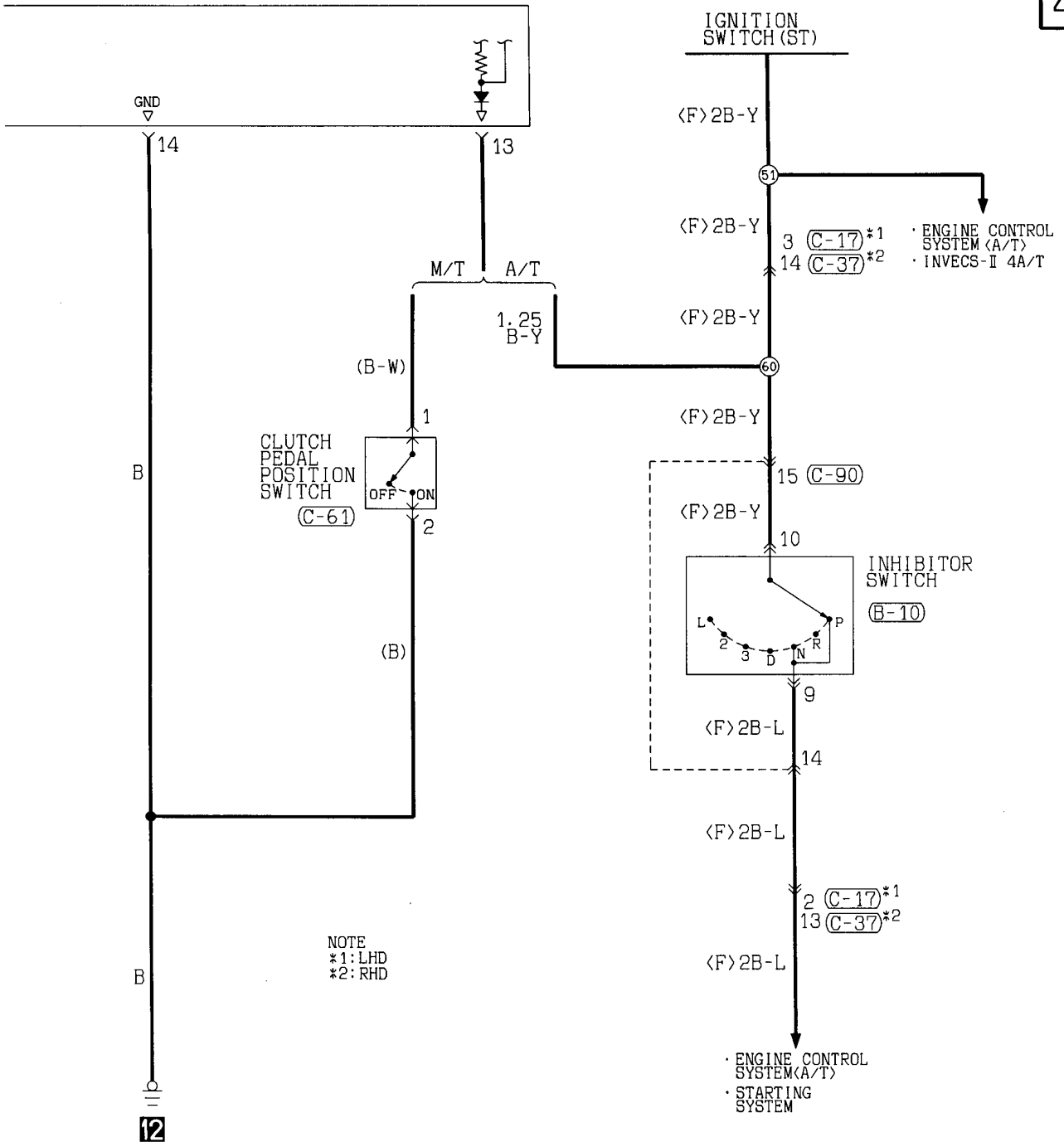

NOTE
*1: LHD
*2: RHD

(C-64)

1	2	3	4	5	6	7	8
9	10	11	12	13	14	15	16

(C-90)

1	2	3	4	5	6	7	8	9	10		
11	12	13	14	15	16	17	18	19	20	21	22

Wire colour code
 B :Black LG:Light green G :Green L):Blue W :White Y :Yellow SB:Sky blue
 BR:Brown O :Orange GR:Gray R):Red P :Pink V :Violet

AUTO-CRUISE CONTROL SYSTEM (CONTINUED)

5

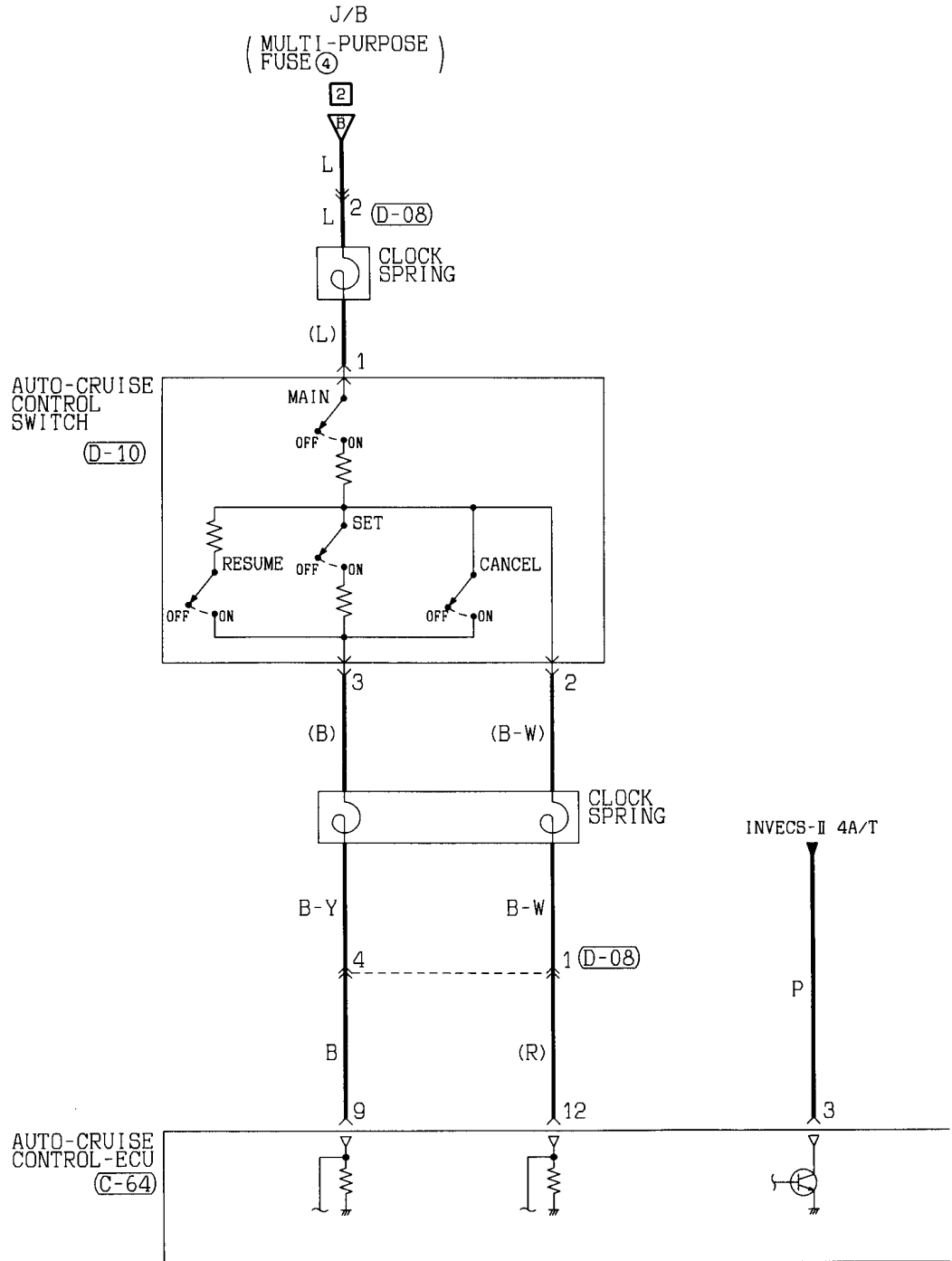

(A-06)

1	2	3	4
---	---	---	---

(C-19)

1	2	3	4	5	6	7	8	9	10	11
12	13	14	15	16	17	18	19	20	21	22
23	24	25	26	27	28	29	30	31	32	33

(C-38)

1	2
3	4
5	6

(C-51)

71	72	73	74	75	76	77	78	79	80	81
82	83	84	85	86	87	88	89	90	91	92

(C-64)

1	2	3	4	5	6	7	8
9	10	11	12	13	14	15	16

(C-71)

1	2	3	4	5	6	7	8	9	10	11
12	13	14	15	16	17	18	19	20	21	22
23	24	25	26	27	28	29	30	31	32	33

6

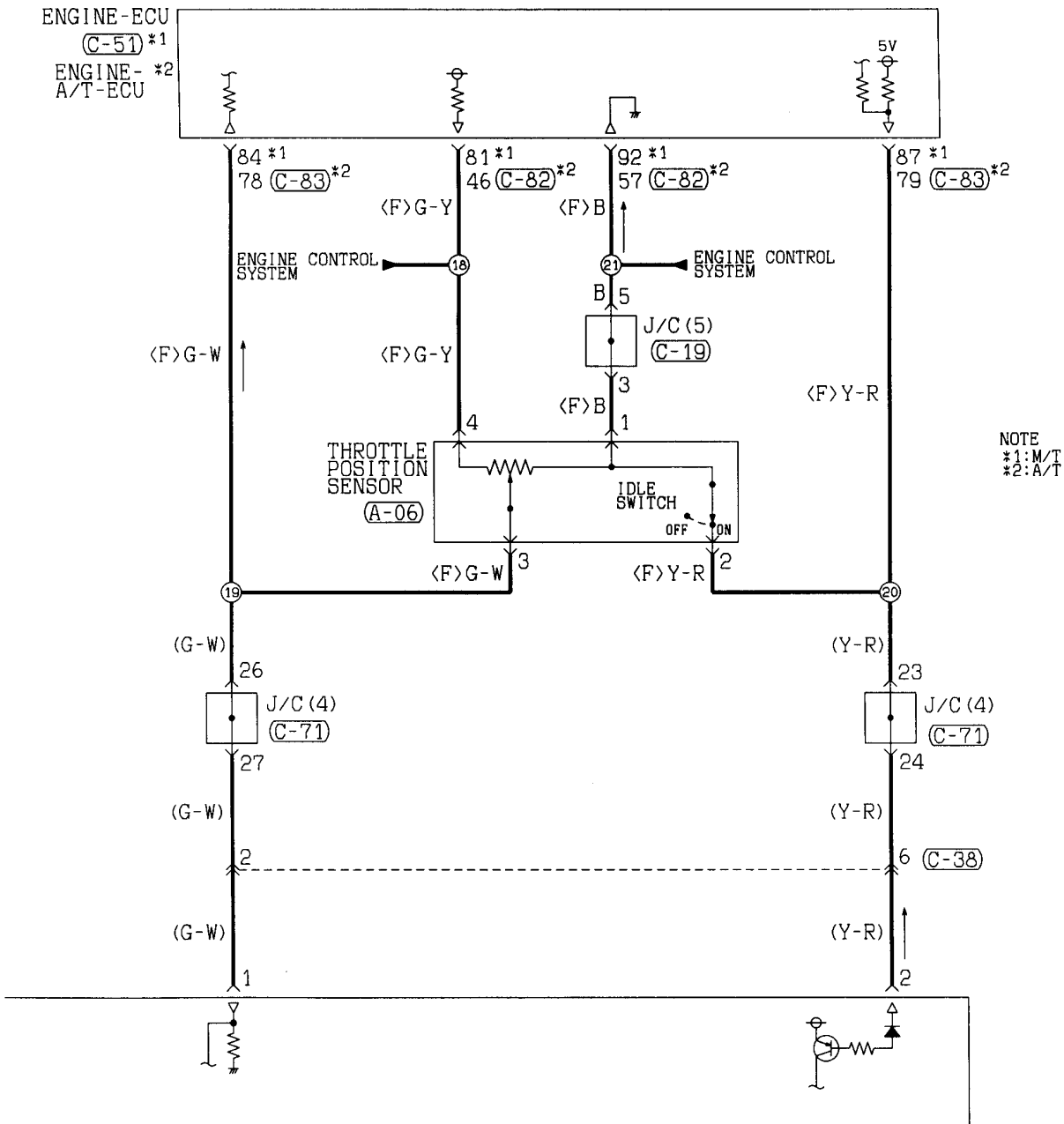

(C-82)

41	42	43		44	45	46				
47	48	49	50	51	52	53	54	55	56	57
58	59	60	61	62	63	64	65	66		

(C-83)

71	72	73	74			75	76	77			
78	79	80	81	82	83	84	85	86	87	88	89
90	91	92	93	94	95	96	97	98			

(D-08)

1	2	3	4

(D-10)

1	2	3

Wire colour code
 B : Black LG : Light green G : Green L : Blue W : White Y : Yellow SB : Sky blue
 BR : Brown O : Orange GR : Gray R : Red P : Pink V : Violet

PART TIME 4WD SYSTEM

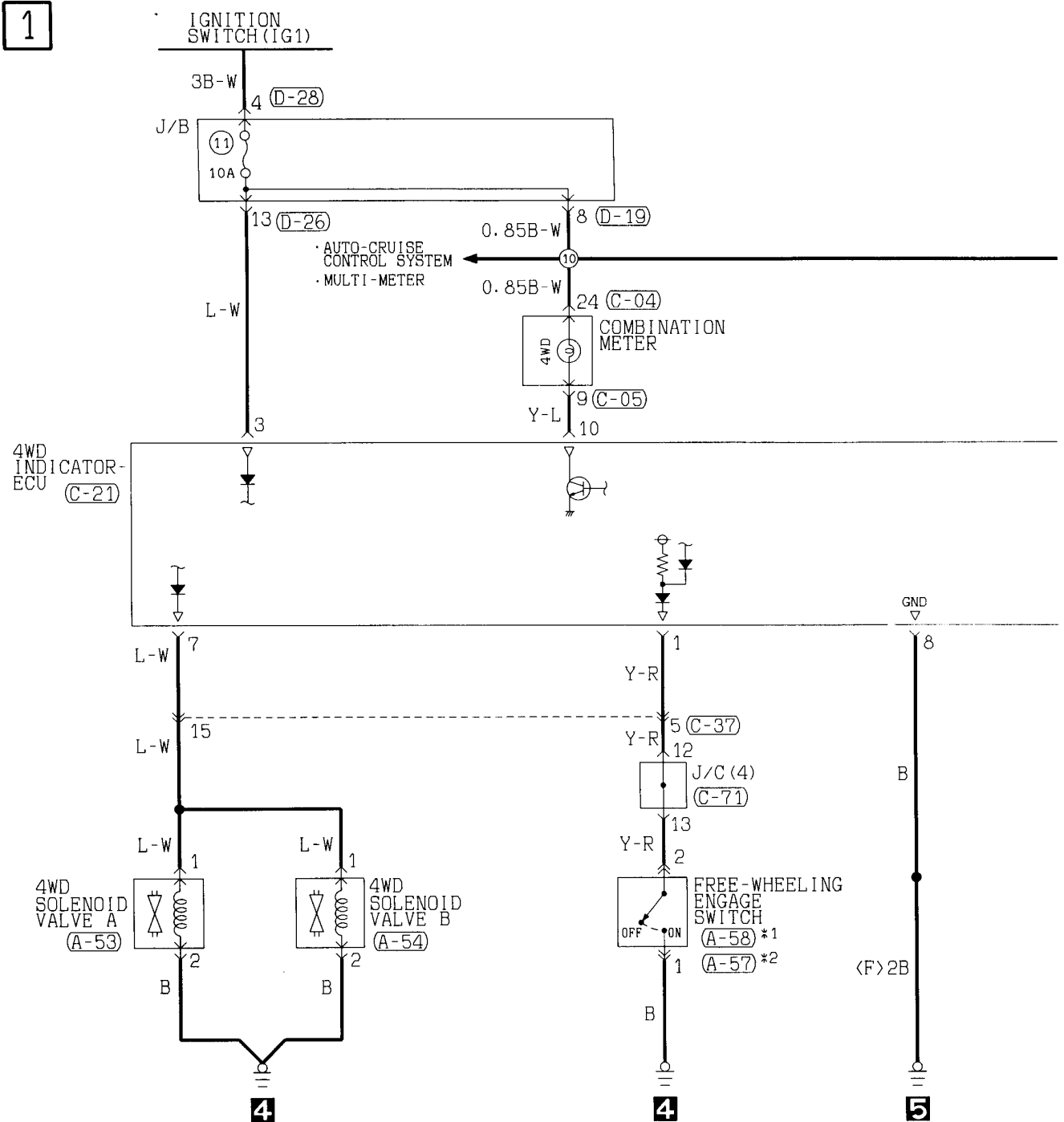

- (A-53)

1
2
- (A-54)

1
2
- (A-57)

1	2
---	---
- (A-58)

1	2
---	---
- (B-03)

1	2	3
---	---	---
- (B-04)

1	2
---	---
- (B-05)

1	2
---	---
- (C-04)

21	22	23	24	25	26	27	28	29	30	31	32
----	----	----	----	----	----	----	----	----	----	----	----
- (C-05)

1	2	3	4	5	6	7	8	9	10	11	12	13	14
---	---	---	---	---	---	---	---	---	----	----	----	----	----
- (D-26)

1	2	3	4	5	6	7	8	9		
10	11	12	13	14	15	16	17	18	19	20
- (D-28)

1	2
3	4

2

NOTE
 *1: WITHOUT
 AUTO-CRUISE
 CONTROL SYSTEM
 *2: WITH
 AUTO-CRUISE
 CONTROL SYSTEM

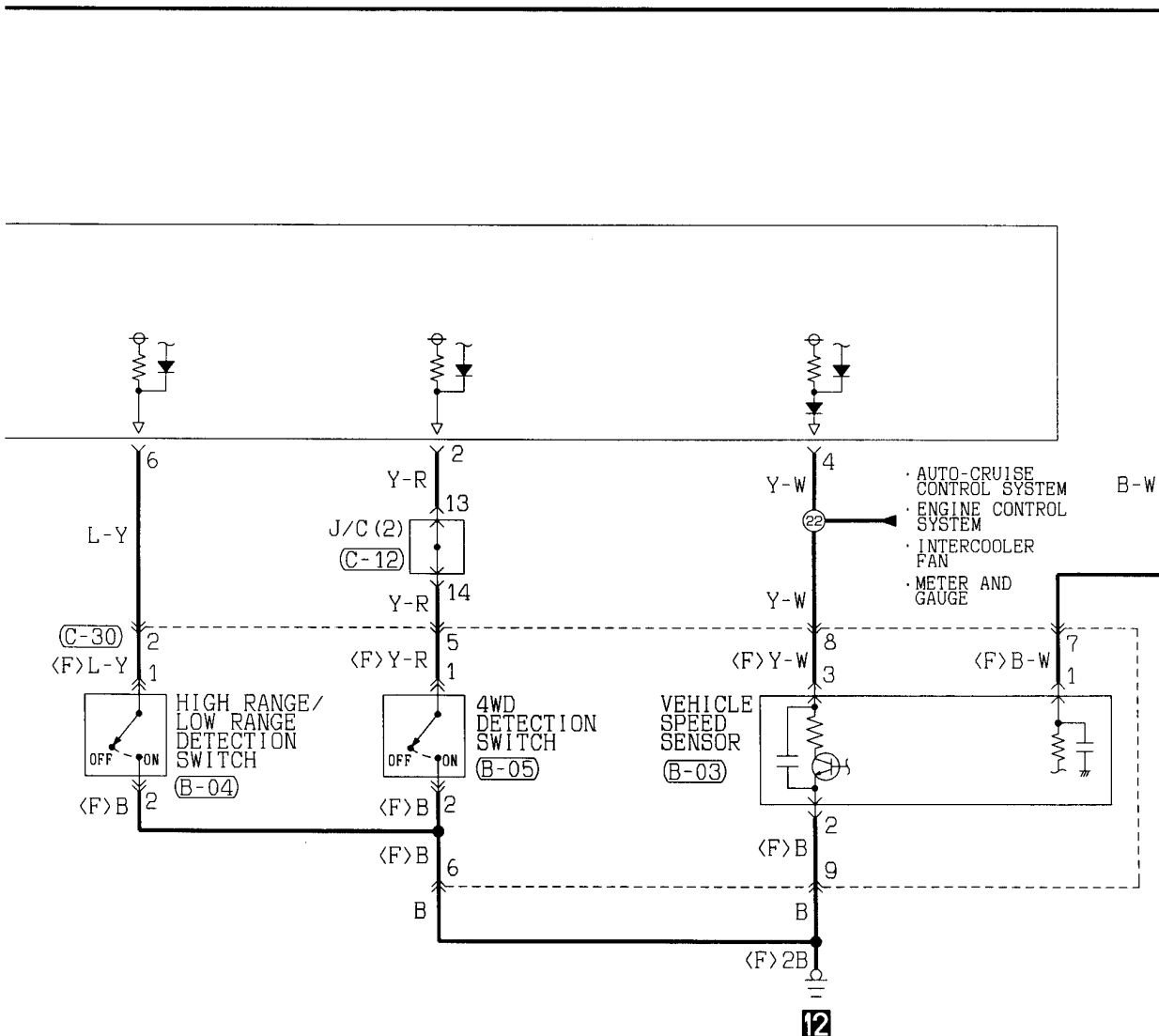

(C-12)	(C-21)	(C-30)	(C-37)	(C-71)	(D-19)
1 2 3 4 5 6 7 8 9 10 11 12 13 14 15 16 17 18 19	1 2 3 4 5 6 7 8 9 10	1 2 3 4 5 6 7 8 9	1 2 3 4 5 6 7 8 9 10 11 12 13 14 15 16 17 18 19 20 21 22	1 2 3 4 5 6 7 8 9 10 11 12 13 14 15 16 17 18 19 20 21 22 23 24 25 26 27 28 29 30 31 32 33	1 2 3 4 5 6 7 8 9 10 11 12 13 14 15 16

Wire colour code
 B :Black LG:Light green G:Green L :Blue W :White Y :Yellow SB:Sky blue
 BR:Brown O :Orange GR:Gray R :Red P :Pink V :Violet

SUNROOF

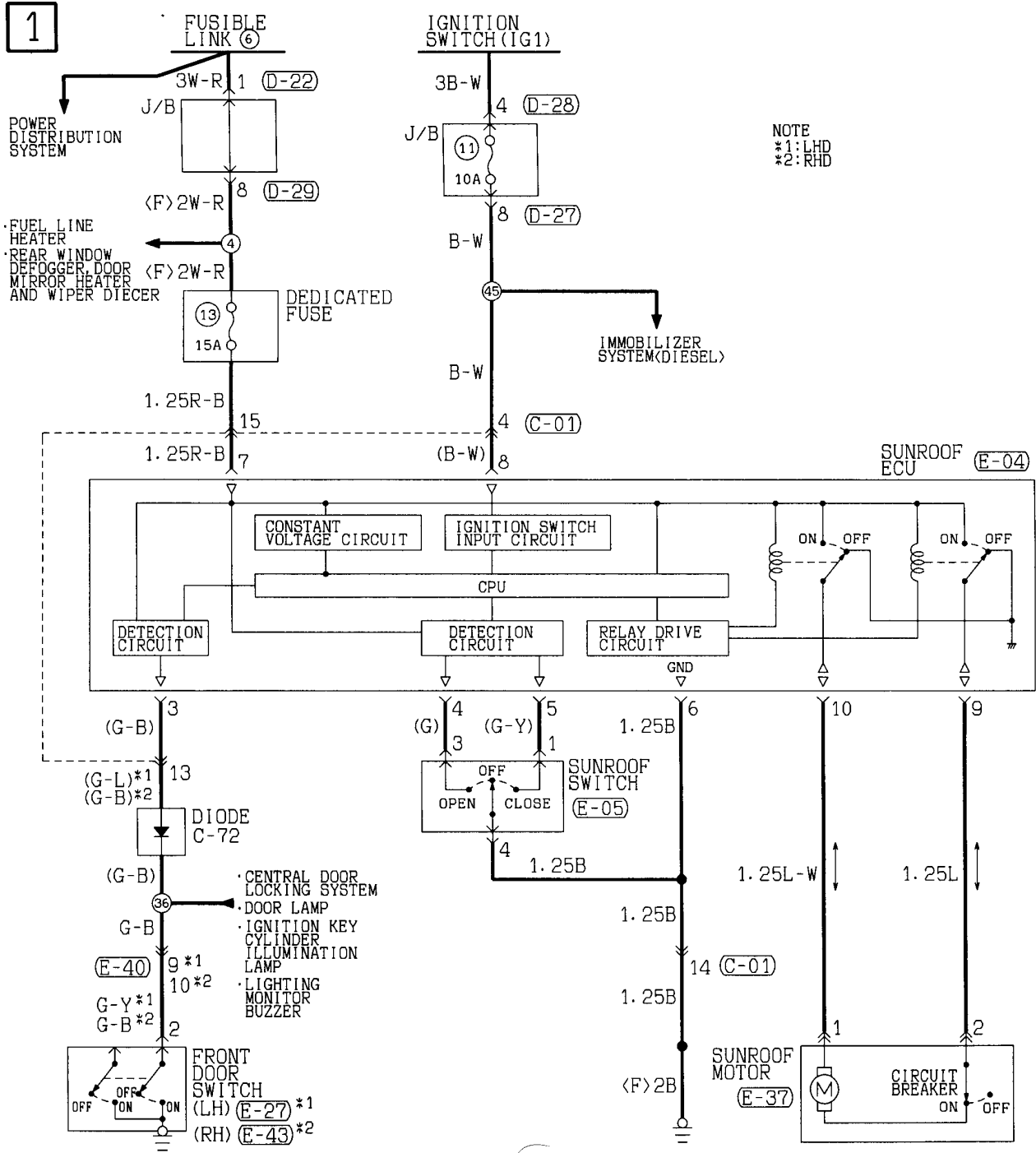

(C-01) (D-22) (D-27) (D-28) (D-29) (E-04) (E-05) (E-27) (E-37)

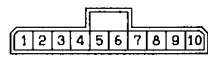
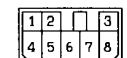
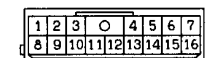
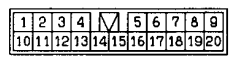

(E-40)

(E-43)

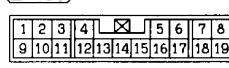

Wire colour code
 B : Black LG: Light green G : Green L : Blue
 BR: Brown O : Orange GR: Gray R : Red
 W : White SB: Sky blue P : Pink Y : Yellow
 V : Violet

NOTES

IMMOBILIZER SYSTEM

Petrol-powered vehicles

1

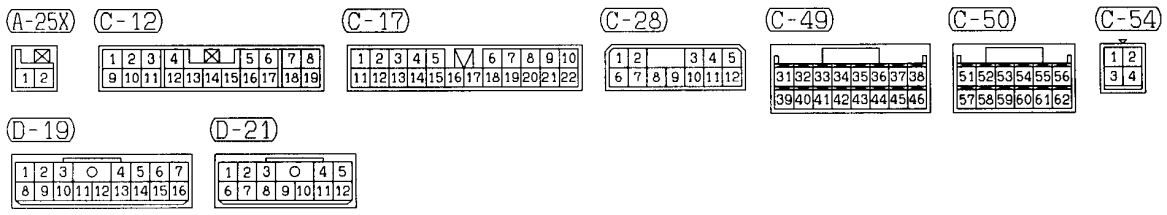
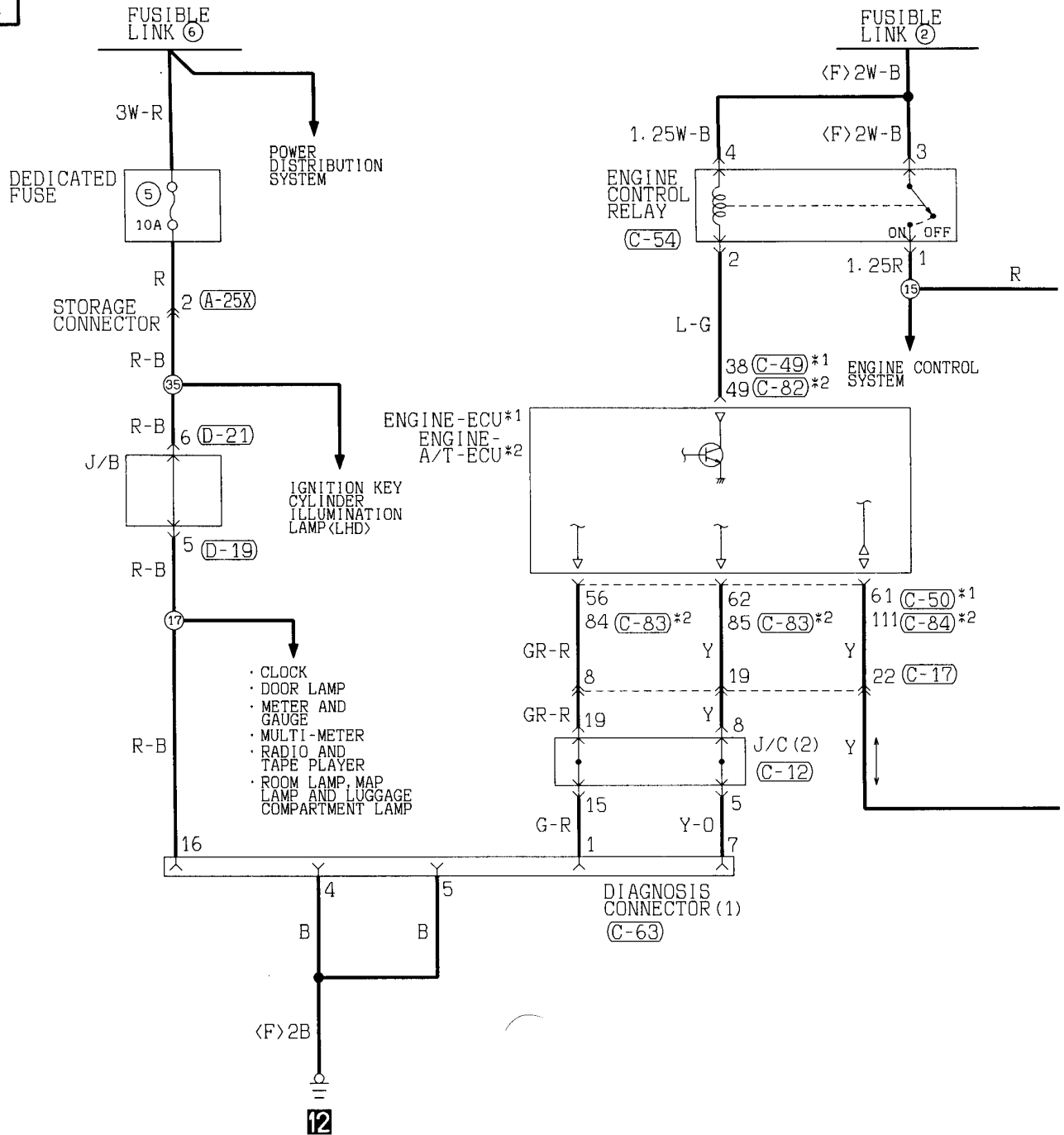

2

NOTE
 #1:M/T
 #2:A/T

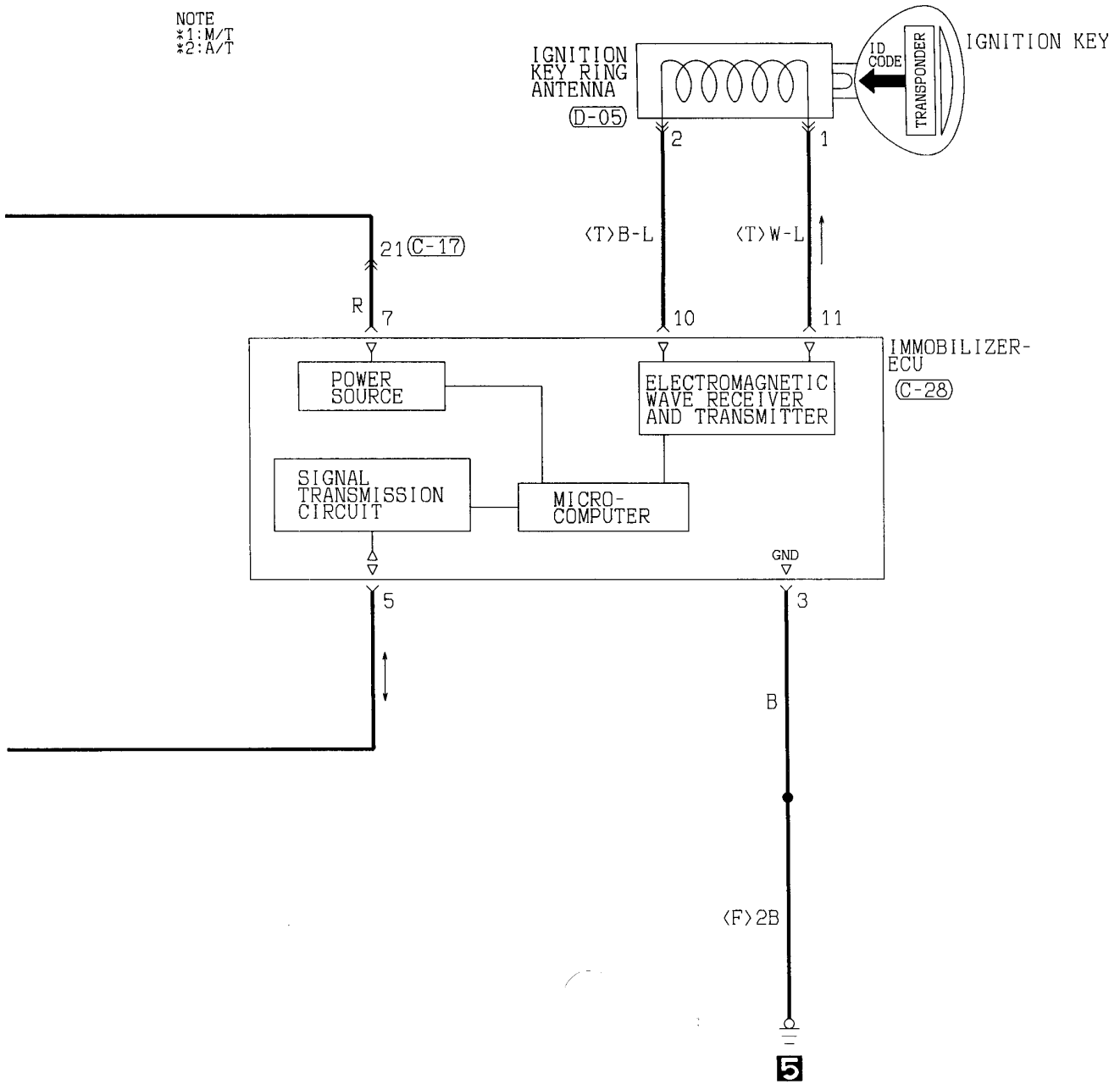

(C-63) FRONT SIDE

1	2	3	4	5	6	7	8
9	10	11	12	13	14	15	16

(C-82)

41	42	43		44	45	46
47	48	49	50	51	52	53
54	55	56	57	58	59	60
61	62	63	64	65	66	

(C-83)

71	72	73	74		75	76	77
78	79	80	81	82	83	84	85
86	87	88	89	90	91	92	93
94	95	96	97	98			

(C-84)

101	102	103	104		105	106	107
108	109	110	111	112	113	114	115
116	117	118	119	120	121	122	123
124	125	126	127	128	129	130	

(D-05)

1	2
---	---

Wire colour code
 B :Black LG:Light green G :Green L :Blue W :White Y :Yellow SB:Sky blue
 BR:Brown O :Orange GR:Gray R :Red P :Pink V :Violet

LIGHTING MONITOR BUZZER

L.H. drive vehicles

1

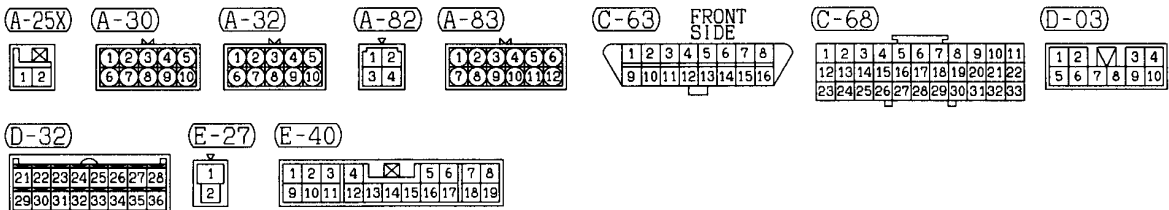
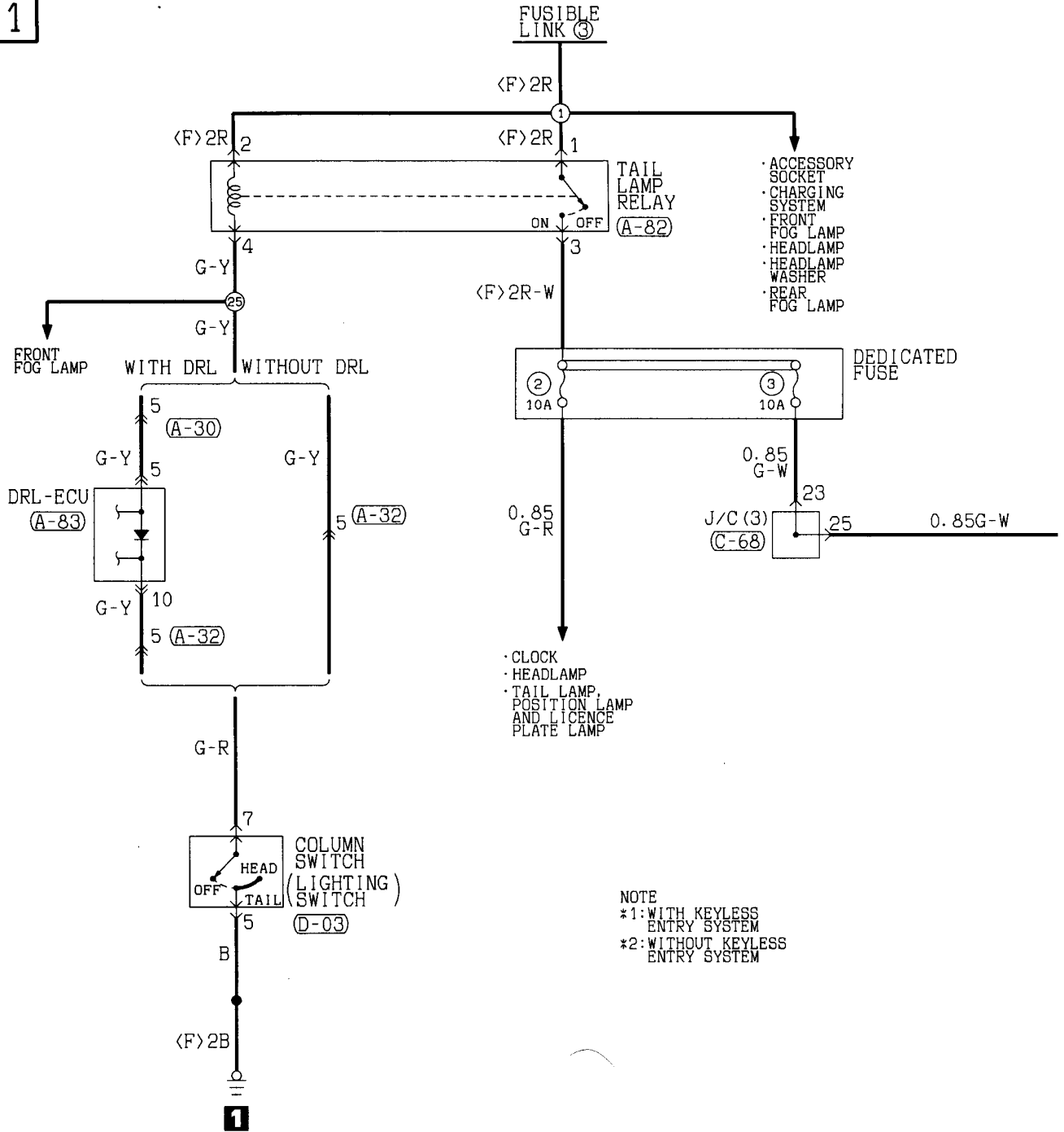

2

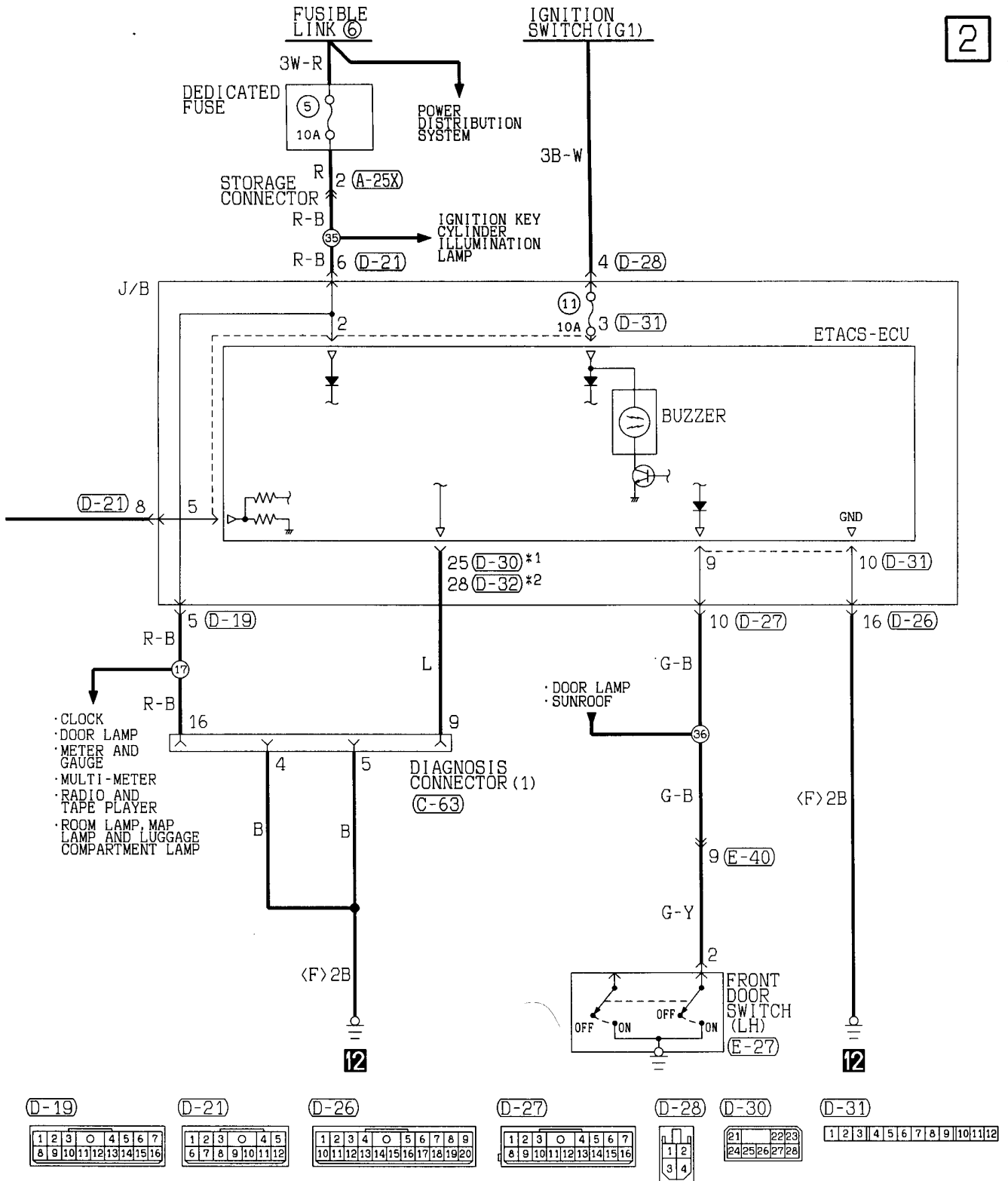

LIGHTING MONITOR BUZZER

R.H. drive vehicles

1

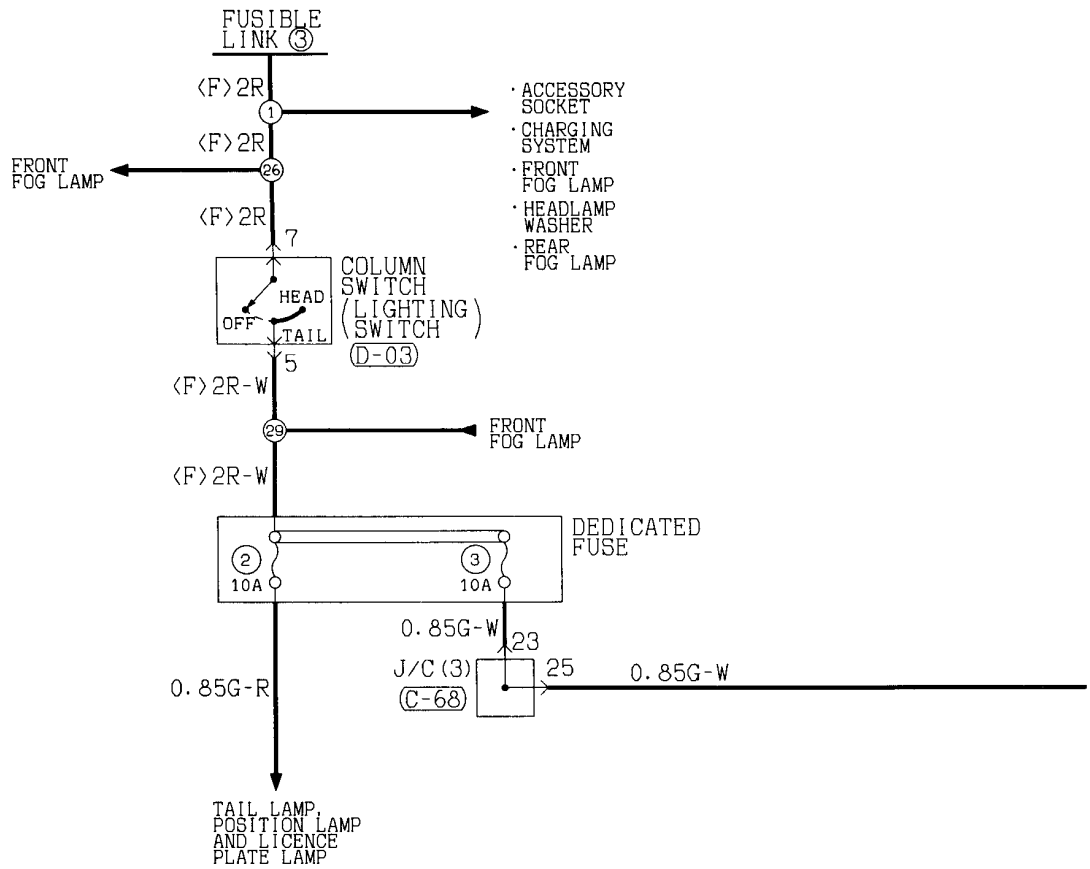

NOTE
 *1: WITH KEYLESS ENTRY SYSTEM
 *2: WITHOUT KEYLESS ENTRY SYSTEM

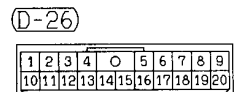
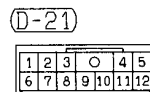
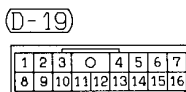
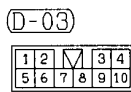
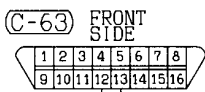

2

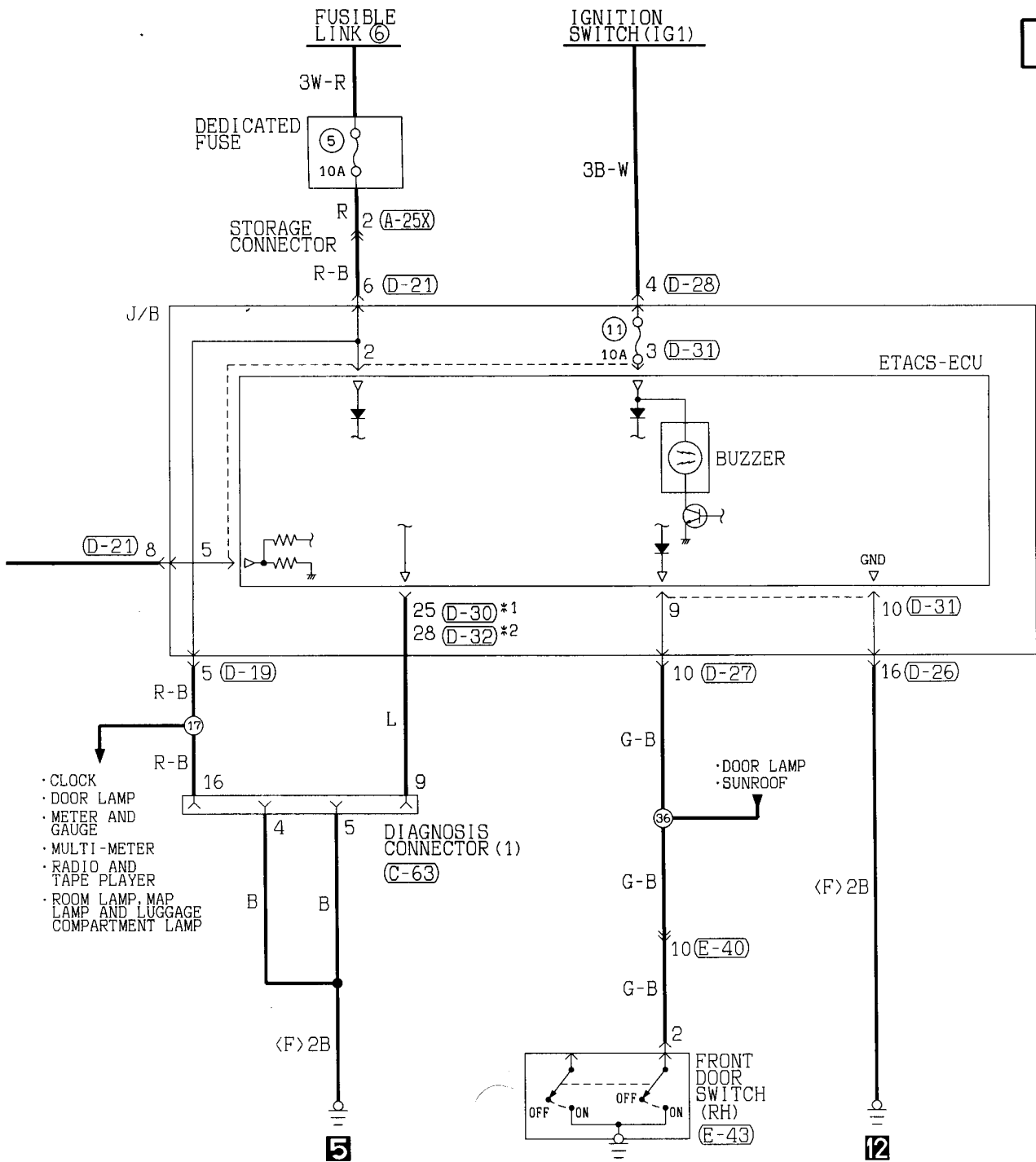

D-27	D-28	D-30	D-31	D-32	E-40	E-43																																																																													
<table border="1"> <tr><td>1</td><td>2</td><td>3</td><td>4</td><td>5</td><td>6</td><td>7</td></tr> <tr><td>8</td><td>9</td><td>10</td><td>11</td><td>12</td><td>13</td><td>14</td><td>15</td><td>16</td></tr> </table>	1	2	3	4	5	6	7	8	9	10	11	12	13	14	15	16	<table border="1"> <tr><td>1</td><td>2</td></tr> <tr><td>3</td><td>4</td></tr> </table>	1	2	3	4	<table border="1"> <tr><td>21</td><td>22</td><td>23</td></tr> <tr><td>24</td><td>25</td><td>26</td><td>27</td><td>28</td></tr> </table>	21	22	23	24	25	26	27	28	<table border="1"> <tr><td>1</td><td>2</td><td>3</td><td>4</td><td>5</td><td>6</td><td>7</td><td>8</td><td>9</td><td>10</td><td>11</td><td>12</td></tr> </table>	1	2	3	4	5	6	7	8	9	10	11	12	<table border="1"> <tr><td>21</td><td>22</td><td>23</td><td>24</td><td>25</td><td>26</td><td>27</td><td>28</td></tr> <tr><td>29</td><td>30</td><td>31</td><td>32</td><td>33</td><td>34</td><td>35</td><td>36</td></tr> </table>	21	22	23	24	25	26	27	28	29	30	31	32	33	34	35	36	<table border="1"> <tr><td>1</td><td>2</td><td>3</td><td>4</td><td>5</td><td>6</td><td>7</td><td>8</td></tr> <tr><td>9</td><td>10</td><td>11</td><td>12</td><td>13</td><td>14</td><td>15</td><td>16</td><td>17</td><td>18</td><td>19</td></tr> </table>	1	2	3	4	5	6	7	8	9	10	11	12	13	14	15	16	17	18	19	<table border="1"> <tr><td>1</td><td>2</td></tr> </table>	1	2
1	2	3	4	5	6	7																																																																													
8	9	10	11	12	13	14	15	16																																																																											
1	2																																																																																		
3	4																																																																																		
21	22	23																																																																																	
24	25	26	27	28																																																																															
1	2	3	4	5	6	7	8	9	10	11	12																																																																								
21	22	23	24	25	26	27	28																																																																												
29	30	31	32	33	34	35	36																																																																												
1	2	3	4	5	6	7	8																																																																												
9	10	11	12	13	14	15	16	17	18	19																																																																									
1	2																																																																																		

Wire colour code
 B :Black LG:Light green G :Green L :Blue W :White Y :Yellow SB:Sky blue
 BR:Brown O :Orange GR:Gray R :Red P :Pink V :Violet

HEATED SEAT

1

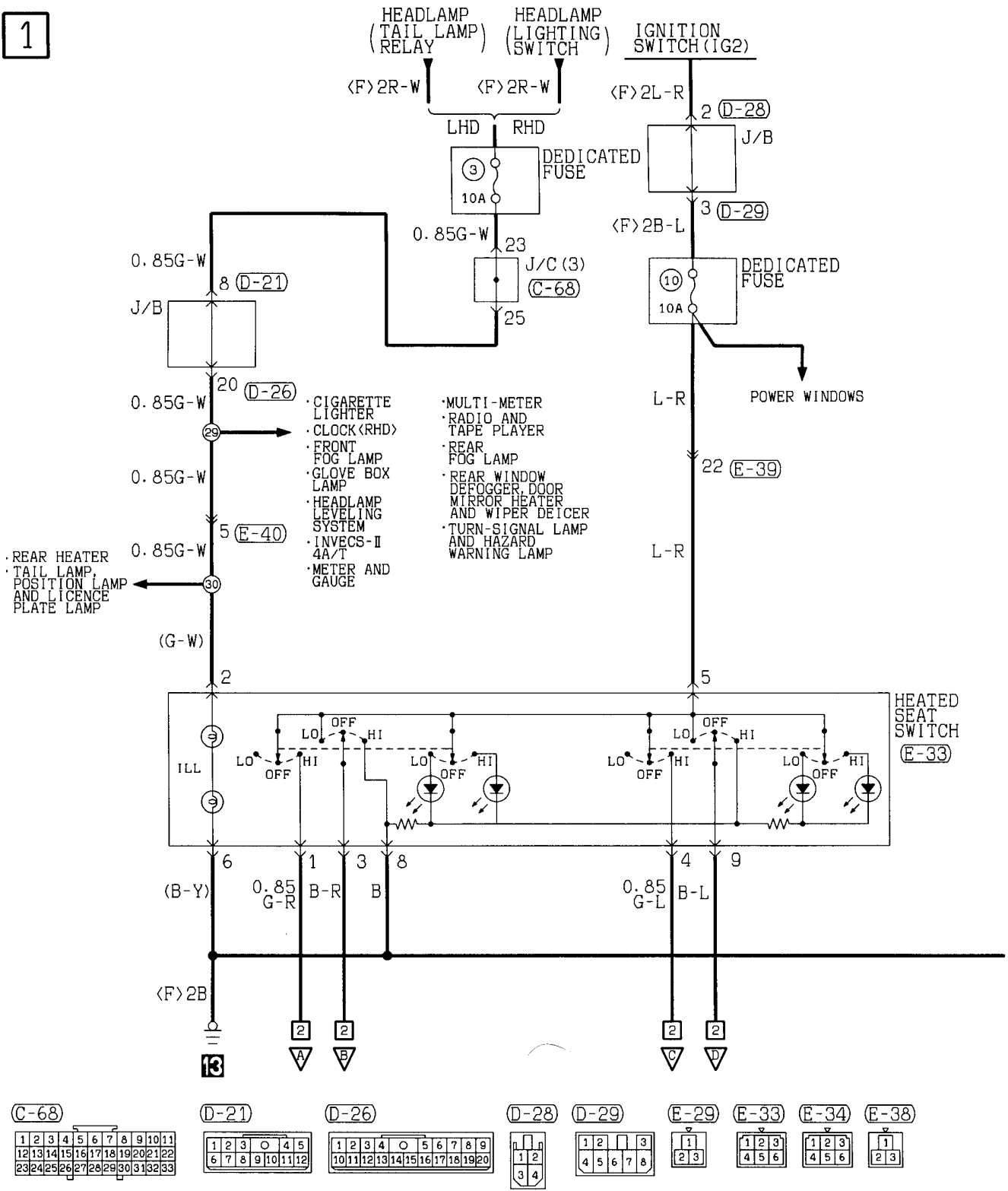

2

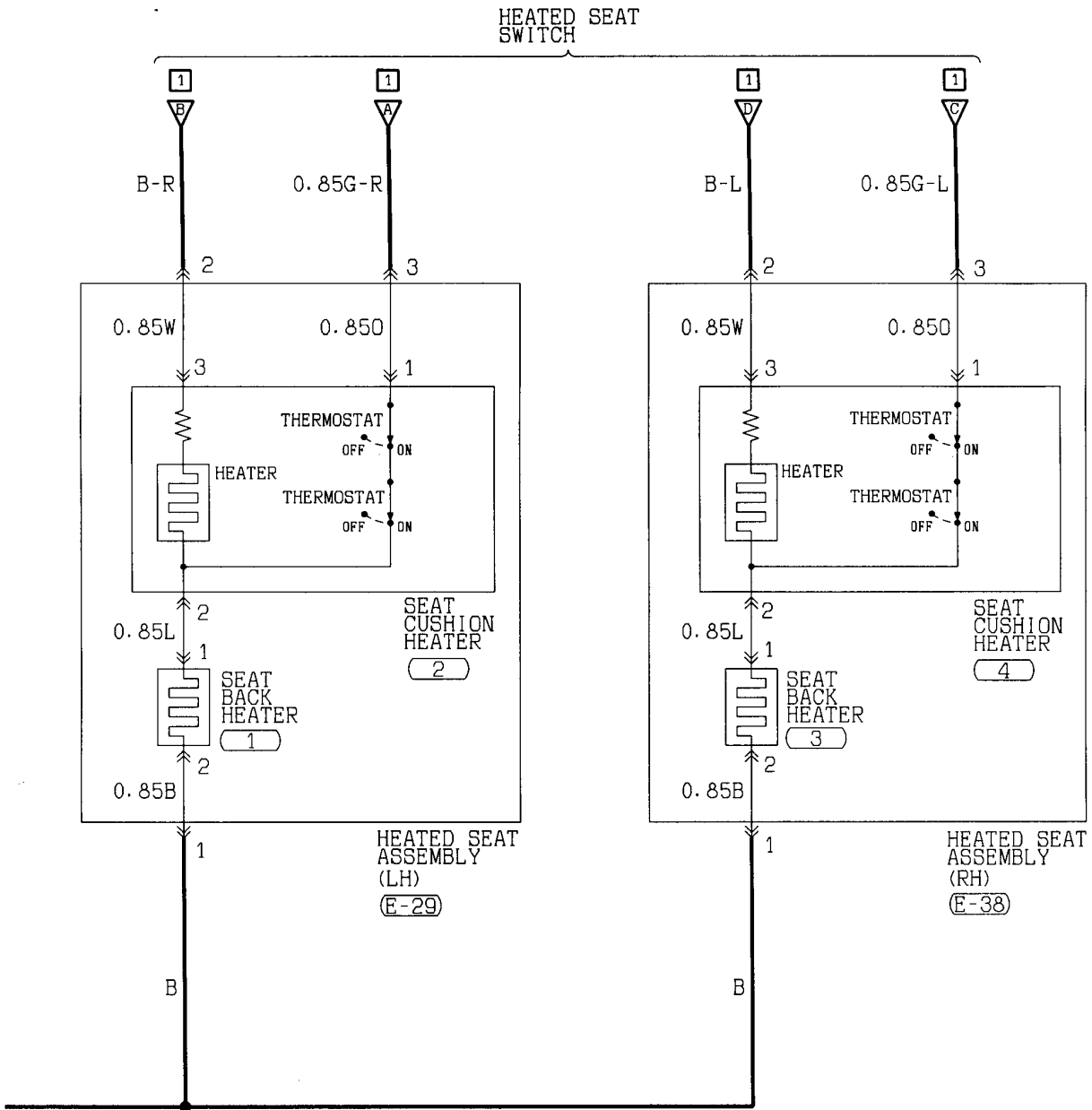

(E-39)

(E-40)

(1) (2) (3) (4)

1	2	3	4	5	6	7	8	9	10		
11	12	13	14	15	16	17	18	19	20	21	22

1	2	3	4	5	6	7	8			
9	10	11	12	13	14	15	16	17	18	19

1
2

1	
2	3

1
2

1	
2	3

Wire colour code
 B : Black LG: Light green G : Green L : Blue W : White Y : Yellow SB: Sky blue
 BR: Brown O : Orange GR: Gray R : Red P : Pink V : Violet

RHEOSTAT

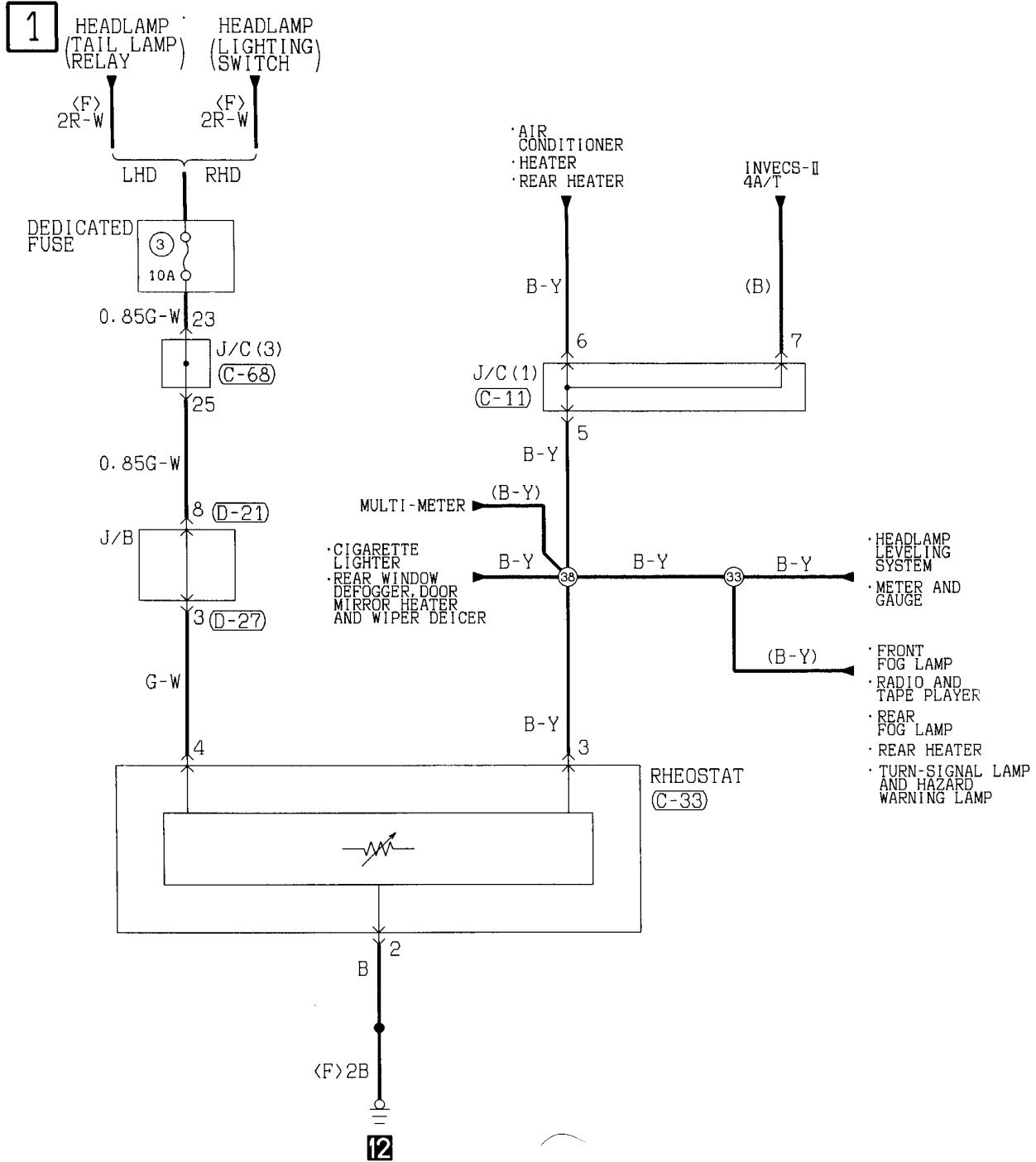

(C-11)

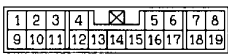

(C-33)



(C-68)

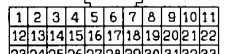

(D-21)

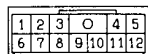

(D-27)

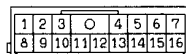

Wire colour code
 B :Black LG:Light green G :Green L :Blue W :White Y :Yellow SB:Sky blue
 BR:Brown O :Orange GR:Gray R :Red P :Pink V :Violet

FUEL LINE HEATER

1

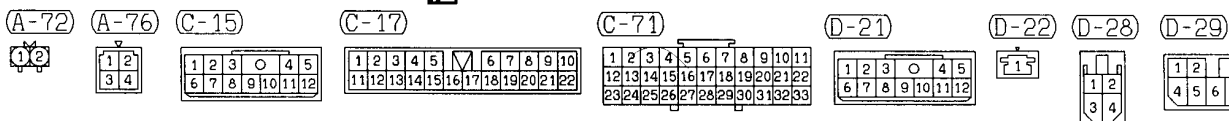
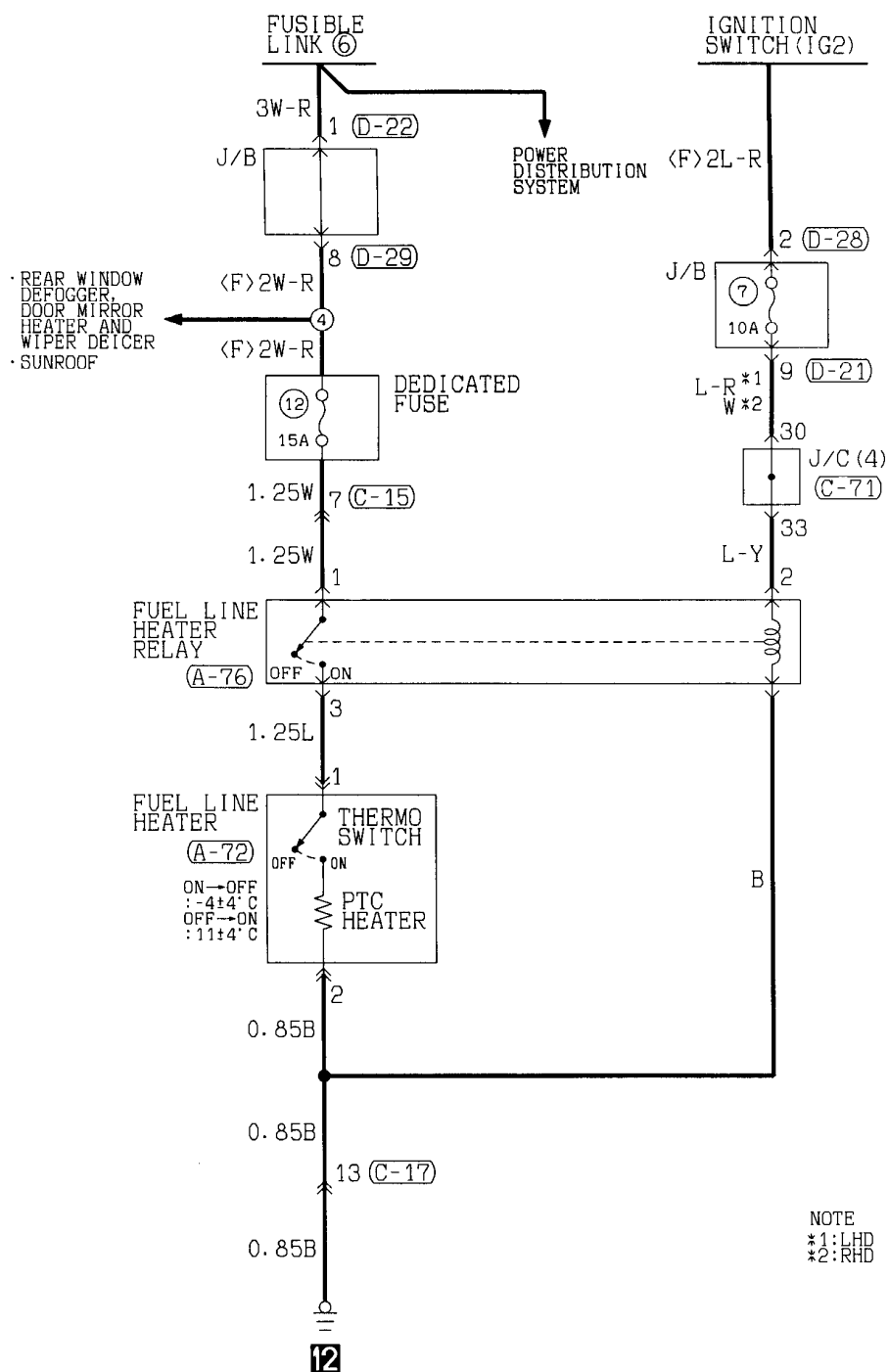

Wire colour code

B : Black LG: Light green G : Green L : Blue W : White Y : Yellow SB: Sky blue

BR: Brown O : Orange GR: Gray R : Red P : Pink V : Violet

